

## Encoders

optical Encoder, digital outputs,  
2 channels, 50 lines per revolution

For combination with  
DC-Micromotors  
Brushless DC-Motors

### Series PA2-50

		PA2-50	
Lines per revolution	$N$	50	
Frequency range, up to <sup>1)</sup>	$f$	35	kHz
Signal output, square wave		2	Channels
Supply voltage	$U_{DD}$	2,7 ... 3,3	V
Current consumption, typical <sup>2)</sup>	$I_{DD}$	8,5	mA
Output current, max.	$I_{OUT}$	8	mA
Pulse width	$P$	180 ± 50	°e
Phase shift, channel A to B	$\Phi$	90 ± 45	°e
Logic state width	$S$	90 ± 50	°e
Cycle	$C$	360 ± 36	°e
Signal rise/fall time, max. ( $C_{LOAD} = 25$ pF)	$tr/tf$	0,3 / 0,1	µs
Inertia of code disc	$J$	0,02	gcm <sup>2</sup>
Operating temperature range		-30 ... +85	°C

<sup>1)</sup> Velocity (min<sup>-1</sup>) =  $f$  (Hz) x 60/ $N$

<sup>2)</sup>  $U_{DD} = 3$  V: with unloaded outputs

#### For combination with Motor

<b>Dimensional drawing A</b>	<L1 [mm]		
0615 ... S - K1655	19,2		
<b>Dimensional drawing B</b>	<L1 [mm]		
0620 ... B - K1719	23,0		
<b>Dimensional drawing C</b>	<L1 [mm]		
0816 ... SR - K2565	24,0		

#### Characteristics

These incremental shaft encoders in combination with the DC-Micromotors and Brushless DC-Servomotors are designed for both indication and control of both shaft velocity and direction of rotation as well as for positioning.

An all-in-one emitter and detector chip transmits and receives LED light reflected off a low inertia reflective disc providing two channels with 90° phase shift.

The supply voltage for the encoder and the Micromotor as well as the output signals are interfaced with a flexible printed circuit (FPC).

Details for the DC-Micromotors and Brushless DC-Servomotors and suitable reduction gearheads are on separate catalog pages.

To view our large range of accessory parts, please refer to the "Accessories" chapter.

**Circuit diagram / Output signals**

**Output circuit**

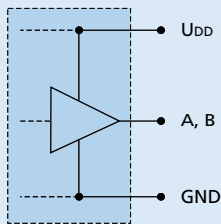

**Output signals**  
with clockwise rotation as seen from the shaft end

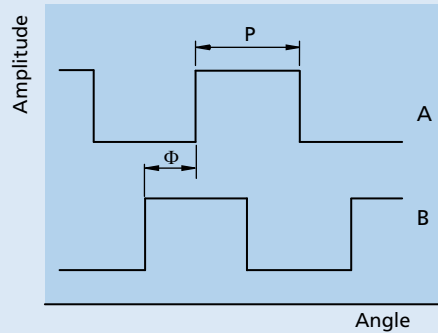

**0615 ... S / 0620 ... B**  
Channel B leads channel A

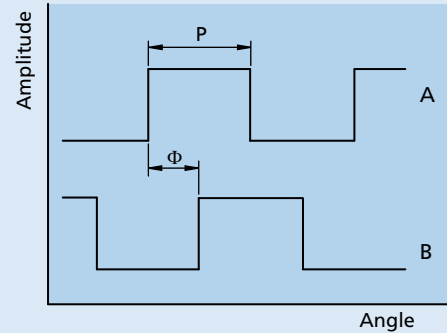

**0816 ... SR**

**Connector information / Variants**

No.	Function
1	Motor + *
2	U <sub>DD</sub>
3	Channel A
4	Channel B
5	GND
6	Motor - *

\* Note: Brushless motors have separate motor leads.

**Connection Encoder**

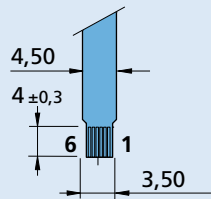

**Recommended connector**  
Molex 52745  
grid 0,5 mm  
FPC / FFC, 6-conductors

**Full product description**

- Examples:  
0615N003S-K1655 PA2-50  
0620K012B-K1719 PA2-50

**Dimensional drawing A**

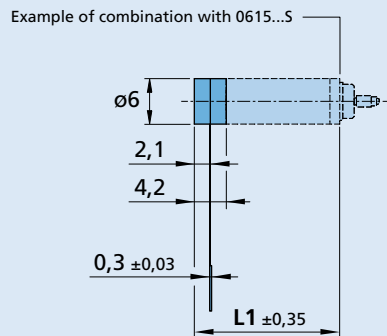

**PA2-50**

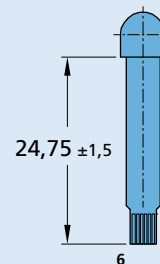

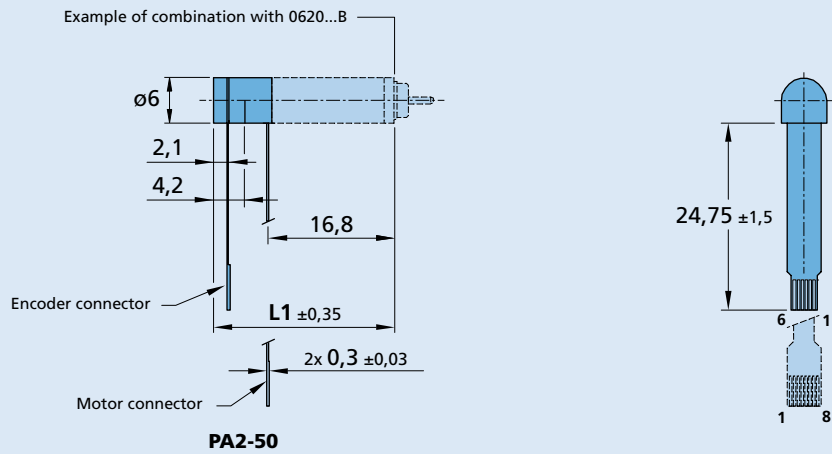
**Dimensional drawing B**

**Dimensional drawing C**
