

Motion Controller

V2.5, 4-Quadrant PWM
with RS232 or CAN interface

For combination with:
Linear DC-Servomotors
with analog Hall sensors

Series MCLM 3003

		MCLM 3003 P	
Power supply	U_B	12 ... 30	V DC
PWM switching frequency	f_{PWM}	78,12	kHz
Efficiency	η	95	%
Max. continuous output current ¹⁾	I_{dauer}	3	A
Max. peak output current	I_{max}	10	A
Total standby current	I_{el}	0,06	A
Speed range ²⁾		2 ... 10 000	mm/s
Scanning rate	N	200	μ s
Encoder resolution with linear Hall Sensors ³⁾		$\leq 3\ 000$	inc./ τ_m
Resolution with external encoder		$\leq 65\ 535$	inc./mm
Input/output (partially free configurable)		3	
Program memory: ⁴⁾			
– memory size		3,3	kWord
– Number of instructions		approx. 1 000	instructions
Operating temperature range		- 40 ... + 85	°C
Housing material		without housing	
Weight		18	g

¹⁾ at 22°C ambient temperature

²⁾ speed in the range 1 ... 5 mm/s may have fluctuations due to the motor type, load characteristics and controller parameters

³⁾ τ_m is the magnetic pitch of the linear motor

⁴⁾ only for version with serial interface

Connection information

Connection communication:			
Interface		RS232	CAN
Communication profile		FAULHABER - ASCII	CANopen
Max. transfer speed rate RS232		115 200	baud
Max. transfer speed rate CAN			1 Mbit/s
Connection 3 "AGND":			
– analog ground		analog GND	
– digital input	external encoder	channel B	
	R_{in}	10	k Ω
	f	≤ 400	kHz
Connection 4 "Fault":			
– digital input		100	k Ω
– digital output (open collector)		$\leq U_B$	V
	I	≤ 30	mA
	clear	switched to GND	
	set	high-impedance	
	fault output	switched to GND	
	error	high-impedance	
	signal output	f	≤ 2 kHz
	resolution	1...255	inc./ τ_m
Connection 5 "AnIn":			
– analog input	set position value	"AGND" as GND	
– digital input	external encoder	± 10	V
		channel A	
	step frequency input	f	≤ 400 kHz
		f	≤ 400 kHz
		R_{in}	5 k Ω
Connection 6 "UB":			
	U_B	12 ... 30	V DC
Connection 7 "GND":			
		ground	
Connection 8 "3. In":			
– digital input		22	k Ω
– electronic supply voltage	U_{EL}	12 ... 30	V DC

Connection information

Connection 9-11 „Sensor A, B, C“:

Hall sensor input	Sensor A	Hall sensor A	
	Sensor B	Hall sensor B	
	Sensor C	Hall sensor C	
	U_{In}	≤ 5	V

Connection 12 “Ucc”:

Output voltage for external use ¹⁾	U_{Out}	5	V DC
Load current	I_{Out}	≤ 60	mA

Connection 13 “SGND”:

Signal GND		Signal ground	
------------	--	---------------	--

Connection 14-16 „Motor A, B, C“:

Motor connection	Motor A	Phase A	
	Motor B	Phase B	
	Motor C	Phase C	
PWM switching frequency	U_{Out} f_{PWM}	0 ... U_B 78,12	V kHz

¹⁾ E.g. Hall Sensors

The signal level (PLC or TTL) of the digital inputs can be set over the interface (see operating instruction manual).
Standard (PLC): Low 0...7V / High 12,5V... U_B , TTL: Low 0...0,5V / High 3,5V... U_B

Options

- Separate power supply (Option no.: 3085)

Accessories

To view our large range of accessory parts, please refer to the “Accessories” chapter.

Full product description

- Example:
MCLM 3003 P RS (RS232)
MCLM 3003 P CF (CANopen with FAULHABER CAN)
MCLM 3003 P CO (CANopen CiA)

Dimensional drawing and connection information MCLM 3003 P

Scale reduced

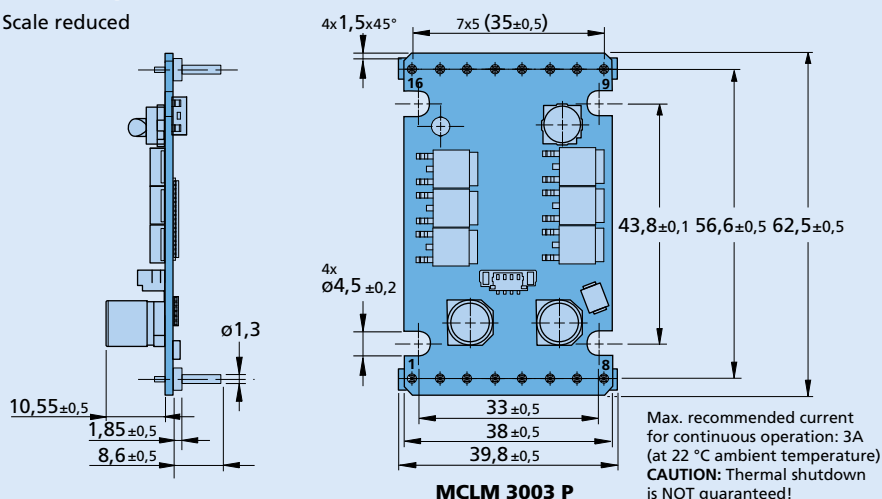

Connection

No.	Function
1	TxD / CAN_H
2	RxD / CAN_L
3	AGND
4	Fault
5	AnIn
6	U_B
7	GND
8	3. In
9	Sensor A
10	Sensor B
11	Sensor C
12	U_{cc}
13	SGND
14	Motor A
15	Motor B
16	Motor C