

Encoders

magnetic Encoder, digital outputs,
2 channels, 64 - 1024 lines per revolution

For combination with
DC-Micromotors
Brushless DC-Motors

Series IE2-1024

		IE2-64	IE2-128	IE2-256	IE2-512	IE2-1024	
Lines per revolution	N	64	128	256	512	1 024	
Frequency range, up to ¹⁾	f	20	40	80	160	300	kHz
Signal output, square wave		2					Channels
Supply voltage	U_{DD}	4,5 ... 5,5					V
Current consumption, typical ²⁾	I_{DD}	typ. 9,5, max. 13					mA
Output current, max. ³⁾	I_{OUT}	5					mA
Phase shift, channel A to B	Φ	90 ± 45					°e
Signal rise/fall time, max. ($C_{LOAD} = 50$ pF)	tr/tf	0,1 / 0,1					µs
Inertia of sensor magnet ⁴⁾	J	0,09					gcm ²
Operating temperature range		-25 ... +85					°C

¹⁾ Velocity (min⁻¹) = f (Hz) x 60/ N

²⁾ $U_{DD} = 5$ V: with unloaded outputs

³⁾ $U_{DD} = 5$ V: low logic level < 0,5 V, high logic level > 4,5 V: CMOS- and TTL compatible

⁴⁾ For the brushless DC-Servomotors the inertia of sensor magnet is: $J = 0,14$ gcm²

For combination with Motor

Dimensional drawing A	<L1 [mm]					
1336 ... CXR - 123	47,5					
Dimensional drawing B	<L1 [mm]					
1516 ... SR	18,2					
1524 ... SR	26,2					
1717 ... SR	19,4					
1724 ... SR	26,4					
2224 ... SR	26,6					
2232 ... SR	34,6					
Dimensional drawing C	<L1 [mm]					
1727 ... CXR - 123	38,2					
1741 ... CXR - 123	52,2					
Dimensional drawing D	<L1 [mm]					
1628 ... B - K313	38,8					
2036 ... B - K313	46,8					
2057 ... B - K313	68,3					

Characteristics

These incremental shaft encoders in combination with the FAULHABER DC-Micromotors and Brushless DC-Servomotors are used for the indication and control of both shaft velocity and direction of rotation as well as for positioning.

The encoder is integrated in the DC-Micromotors SR-Series and extends the overall length by only 1,4 mm. Built-on option for DC-Micromotors and Brushless DC-Servomotors.

Hybrid circuits with sensors and a low inertia magnetic disc provide two channels with 90° phase shift.

The supply voltage for the encoder and the DC-Micromotor as well as the two channel output signals are interfaced through a ribbon cable with connector.

Details for the DC-Micromotors and suitable reduction gearheads are on separate catalogue pages.

To view our large range of accessory parts, please refer to the "Accessories" chapter.

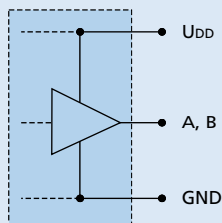
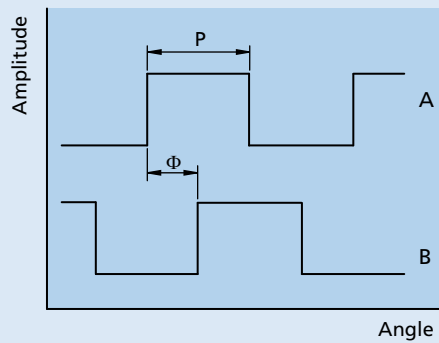
Circuit diagram / Output signals
Output circuit

Output signals
with clockwise rotation as seen from the shaft end

Connector information / Variants

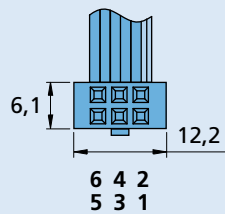
No.	Function
1	Motor - *
2	Motor + *
3	GND
4	U _{DD}
5	Channel B
6	Channel A

*Note: The terminal resistance of all motors with precious metal commutation is increased by approx. 0.4 Ω, and the max. allowable motor current in combination is 1A, depending on the motor can also be lower. Brushless DC-Servomotors and DC-Micromotors series CXR have separate motor leads and higher motor current is allowed.

Connection Encoder

Cable
PVC-ribbon cable
6-conductors, 0,09 mm²

Connector
DIN-41651
grid 2,54 mm

Full product description

- Example:
1336U012CXR-123 IE2-1024
1516T006SR IE2-256

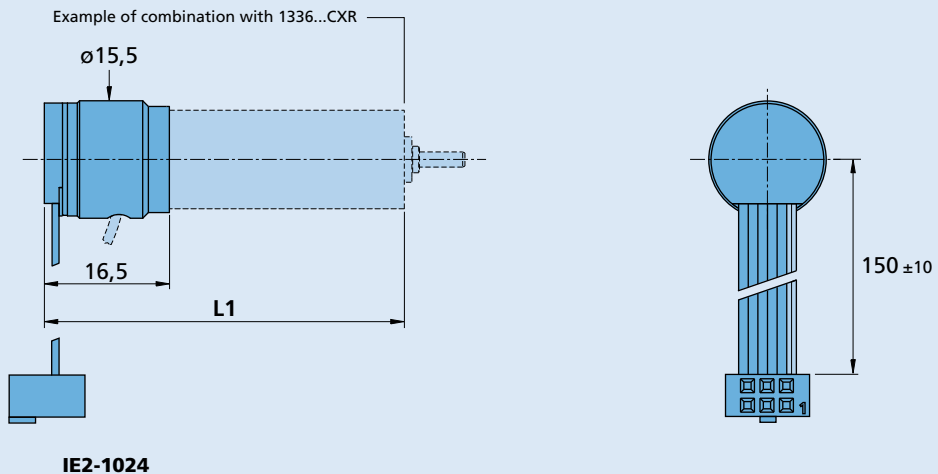
Dimensional drawing A

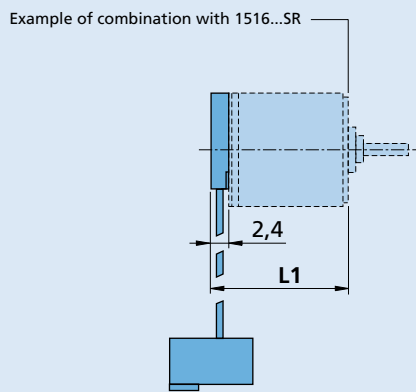
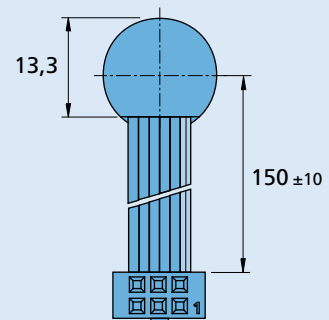
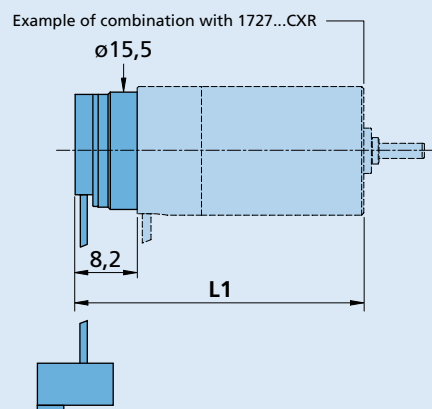
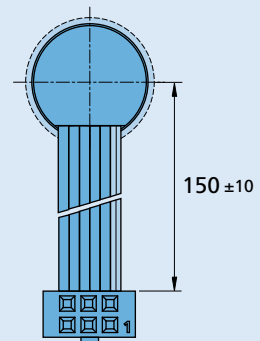
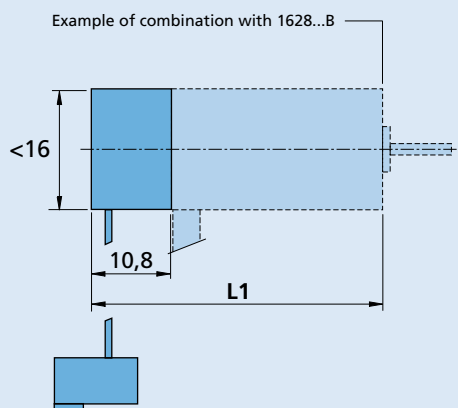
Dimensional drawing B

IE2-1024

Dimensional drawing C

IE2-1024

Dimensional drawing D

IE2-1024
