

Brushless DC-Servomotors

with integrated Motion Controller
and RS232 or CAN interface

56 mNm

For combination with
Gearheads:
32A, 32ALN, 32/3, 32/3 S, 38/1, 38/1 S, 38/2, 38/2 S
Ball Screw:
BS32-2.0

3242 ... BX4 Cx

	3242 G		024 BX4 CS/CC/CO	
1 Nominal voltage	U_N		24	V DC
2 Terminal resistance, phase-phase	R		3,6	Ω
3 Efficiency	η_{max}		77,3	%
4 No-load speed	n_o		5 200	min^{-1}
5 No-load current ³⁾	I_o		0,098	A
6 Stall torque at 5A	M_H		209	mNm
7 Friction torque, static	C_o		1,3	mNm
8 Friction torque, dynamic	C_v		$5,2 \cdot 10^{-4}$	$\text{mNm}/\text{min}^{-1}$
9 Speed constant	k_n		227	min^{-1}/V
10 Back-EMF constant	k_E		4,409	$\text{mV}/\text{min}^{-1}$
11 Torque constant	k_M		42,1	mNm/A
12 Current constant	k_I		0,0238	A/mNm
13 Slope of n-M curve	$\Delta n/\Delta M$		19,4	$\text{min}^{-1}/\text{mNm}$
14 Terminal inductance, phase-phase	L		240	μH
15 Mechanical time constant	τ_m		6,1	ms
16 Rotor inertia	J		30	gcm^2
17 Angular acceleration	α_{max}		66	$\cdot 10^3 \text{rad}/\text{s}^2$
18 Thermal resistance	R_{th1} / R_{th2}	1,6 / 12,4		K/W
19 Thermal time constant	τ_{w1} / τ_{w2}	9 / 810		s
20 Operating temperature range		- 40 ... +85		$^{\circ}\text{C}$
21 Shaft bearings		ball bearings, preloaded		
22 Shaft load max.:				
- radial at 3 000 min^{-1} (4,5 mm from mounting flange)		50		N
- axial at 3 000 min^{-1} (push / pull)		5		N
- axial at standstill (push / pull)		50		N
23 Shaft play:				
- radial	\leq	0,015		mm
- axial	$=$	0		mm
24 Housing material		motor: stainless steel; controller housing: zinc, black anodized		
25 Weight		370		g
26 Direction of rotation		electronically reversible		

Recommended values - mathematically independent of each other

27 Speed up to	$n_{e max}$		5 - 6 500	min^{-1}
28 Torque up to ^{1) 2)}	$M_{e max}$		35 / 56	mNm
29 Current up to ^{1) 2) 3)}	$I_{e max}$		1,00 / 1,58	A

¹⁾ at 4 000 min^{-1} ²⁾ thermal resistance R_{th2} not reduced / thermal resistance R_{th2} by 55% reduced

³⁾ total standby current 0,055 A at $U_B = 24\text{V}$

Note:

The diagram indicates the maximum speed in relation to the available torque at the output shaft for a given ambient temperature of 22°C.

The motor can provide more power with adequate cooling (for ex. R_{th2} reduction of -55%).

The maximum available torque and speed will be reduced if the ambient temperature is higher than 22°C and/or the motor is thermally insulated to the ambient environment.

The characteristics of the curve diagram is determined by U_B and the control characteristics of the integrated Motion Controller.

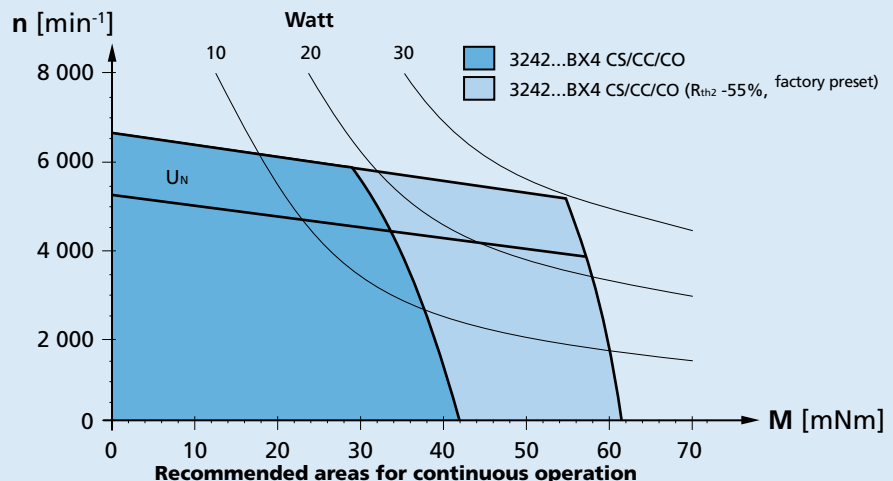

Dimensional drawing

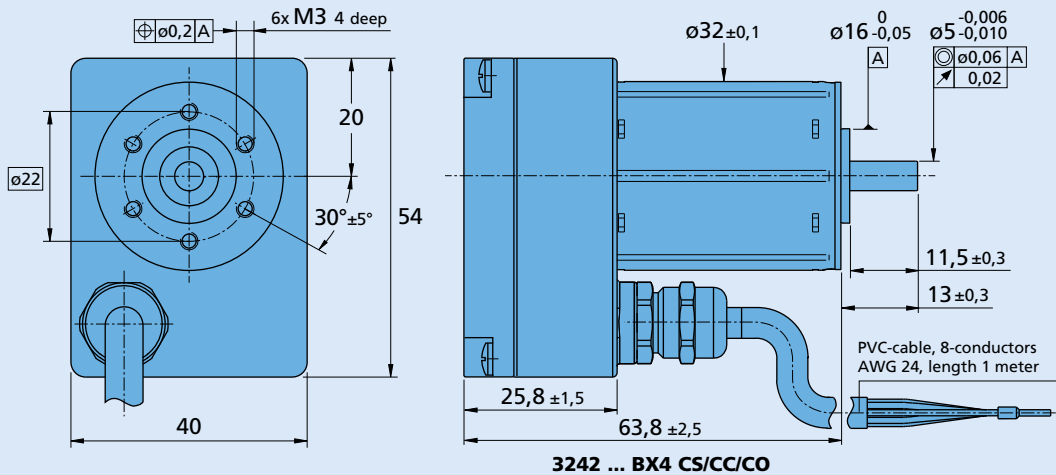

Scale reduced 

Connection

Wires	Function
blue	GND
pink	U_B
brown	Analog input
white	Fault output
grey	Analog GND
yellow	RS232 RXD / CAN_L
green	RS232 TXD / CAN_H
red	Connection No. 3

Caution:

Connect motor supply terminals to the correct polarity. Electronics are protected against polarity reversal by an internal fuse. In case of damage, this internal fuse can only be replaced at the factory.

Options

Accessories

- To view our large range of accessory parts, please refer to the "Accessories" chapter.

Full product description

- Example:
 - 3242G024 BX4 CS (RS232 interface)
 - 3242G024 BX4 CC (CANopen with FAULHABER CAN)
 - 3242G024 BX4 CO (CANopen CiA)

Motion Controller

Supply voltage ¹⁾	U_B		12 ... 30	V DC
Peak current ²⁾	I_{max}		5	A
Input/output			3	
Connection "Analog input":				
- Speed command analog input		voltage range	±10	V
- Speed command PWM input		frequency range	100 ... 2 000	Hz
		pulse duty factor 50%	0	min ⁻¹
- Digital input		input resistance (at 24V)	5	kΩ
- External encoder	f_{max}		400	kHz
- Step frequency input	f_{max}		400	kHz
Connection "Fault output":				
- Fault output		no error	switched to GND	
- Digital output		open collector	max. $U_B / 30$ mA	
- Digital input		input resistance	100	kΩ
Connection "3.input":				
- Digital input		input resistance	22	kΩ
- Electronic supply voltage ¹⁾	U_{EL}		12 ... 30	V DC
Encoder:				
- Scanning rate			200	μs
- Resolution internal encoder			3 000	Inc./turn

The signal level of the digital inputs can be set using the above commands:
Standard (PLC): Low 0...7,0V / High 12,5V... U_B , TTL: Low 0...0,5V / High 3,5V... U_B

¹⁾ Separate supply of motor and control electronics for safetyrelevant applications is optionally available (Option no. 2993).

In this case the 3rd input is not available for digital signals; connection 3.

²⁾ Preset value. Can be changed over the interface.