

DC-Gearmotors

30 mNm

Precious Metal Commutation

Series 1512 ... SR

Values at 22°C and nominal voltage		1512 U	003 SR	006 SR	012 SR	
Nominal voltage	U_N		3	6	12	Volt
Terminal resistance	R		13,6	60,5	156	Ω
No-load speed (motor)	n_o		11 100	11 980	12 800	min^{-1}
Speed constant	k_n		3 884	2 053	1 107	min^{-1}/V
Back-EMF constant	k_E		0,257	0,487	0,903	$\text{mV}/\text{min}^{-1}$
Torque constant	k_M		2,46	4,65	8,63	mNm/A
Current constant	k_I		0,407	0,215	0,116	A/mNm
Slope of n-M curve	$\Delta n/\Delta M$		21 330	24 135	19 947	$\text{min}^{-1}/\text{mNm}$
Rotor inductance	L		275	1 157	3 550	μH
Rotor inertia	J		0,08	0,08	0,08	gcm^2

Housing material		plastic				
Geartrain material		metal				
Backlash, at no-load	\leq	4				$^\circ$
Bearings on output shaft		plastic / brass bearing				
Shaft load max.:						
– radial (5 mm from mounting face)	\leq	1,4				N
– axial	\leq	1				N
Shaft press fit force, max.	\leq	15				N
Shaft play:						
– radial (5 mm from mounting face)	\leq	0,08				mm
– axial	\leq	0,25				mm
Operating temperature range		- 25 ... + 80				$^\circ\text{C}$

Specifications

reduction ratio (rounded)	output speed up to n_{max} min^{-1}	weight with motor g	output torque		direction of rotation (reversible)	efficiency %
			continuous operation M_{max} mNm	intermittent operation M_{max} mNm		
6 : 1	779	6,9	1,4	3	=	81
13 : 1	372	7,0	2,8	5	\neq	73
39 : 1	129	7,2	7,0	10	=	60
112 : 1	45	7,4	19,8	30	\neq	59
324 : 1	15	7,7	30,0	50	=	53

Note: output speed at 5000 min^{-1} input speed. Based on motor 1506 ... SR.

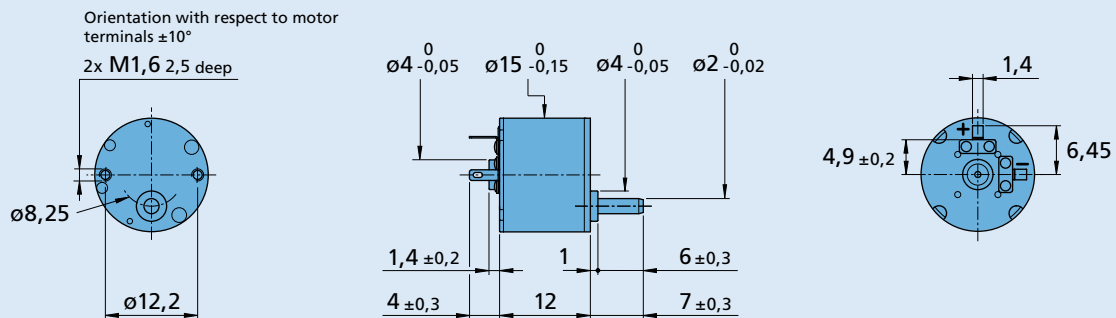

1512 U ... SR