

NEW

Motion Controller

4-Quadrant PWM
with RS232 interface

For combination with:
DC-Micromotors

Series MCDC 3003/06 S

		MCDC 3003 S	MCDC 3006 S	
Power supply	U_B	12 ... 30	12 ... 30	V DC
PWM switching frequency	f_{PWM}	78,12	78,12	kHz
Efficiency	η	95	95	%
Max. continuous output current ¹⁾	I_{dauer}	3	6	A
Max. peak output current	I_{max}	10	10	A
Total standby current	I_{el}	0,06	0,06	A
Speed range		5 ... 30 000	5 ... 30 000	rpm
Scanning rate	N	100	100	μ s
Encoder resolution with Hall Sensors		$\leq 65\ 535$	$\leq 65\ 535$	lines/rev.
Input/output (partially free configurable)		5	5	
Program memory:				
– memory size		3,3	3,3	kWord
– Number of instructions		ca. 1 000	ca. 1 000	instructions
Operating temperature range		0 ... + 70	0 ... + 70	°C
Storage temperature		– 25... + 85	– 25 ... + 85	°C
Housing material		without housing	aluminium, black anodized	
Weight		18	160	g

¹⁾ at 22°C ambient temperature

Connection information

Connection "TxD", "RxD":				
Interface			RS232	
Communication profile			Faulhaber - ASCII	
Max. transfer speed rate			115 200	baud
Connection "AGND":				
– analog ground			analog GND	
– digital input	external encoder		channel B	
	R_{in}		10	k Ω
	f		≤ 400	kHz
Connection "Fault":				
– digital input			channel B	
– digital output (open collector)				
	R_{in}		100	k Ω
	U		$\leq U_B$	V
	I		≤ 30	mA
	clear		switched to GND	
	set		high-impedance	
fault output	no error		switched to GND	
	error		high-impedance	
Connection "AnIn":				
– analog input	set speed value	U_{in}	± 10	V
– digital input	PWM set speed value	f	100 ... 2 000	Hz
		T	50% \pm 0 rpm	
	external encoder		channel A	
		f	≤ 400	kHz
	step frequency input	f	≤ 400	kHz
		R_{in}	5	k Ω
Connection "+24V":				
		U_B	12 ... 30	V DC
Connection "GND":				
			ground	
Connection "3. In":				
– digital input		R_{in}	22	k Ω
– electronic supply voltage ²⁾		U_B	12 ... 30	V DC
Connection "4. In":				
– digital input		R_{in}	22	k Ω
Connection "5. In":				
– digital input		R_{in}	22	k Ω

²⁾ Optional on request

Specification subject to change without notice

JAN-2008

Connection information

Connection "Mot -", "Mot +":

Motor connection	Mot - Mot +		Motor - Motor +	
PWM switching frequency		U_{out} f_{PWM}	$0 \dots U_B$ 78,12	V kHz

Connection "Ch A", "Ch B":

Hall sensor input	CH A CH B		encoder channel A encoder channel B	
Integrated pullup resistance + 5V		R f	2,2 ≤ 400	k Ω kHz

Connection "SGND":

Signal GND			signal ground	
------------	--	--	---------------	--

Connection "+5V":

Output voltage for external use ¹⁾		U_{out}	5	V DC
Load current		I_{out}	≤ 60	mA

¹⁾ E.g. encoder

D-SUB-connector information

Connection D-SUB-connector:

Pin 2	RxD		RS232 / RxD	
Pin 3	TxD		RS232 / TxD	
Pin 5	GND		Ground	

Digital inputs general information

- PLC, default	high low	$12,5 \dots U_B$ $0 \dots 7$	V V
- TTL	high low	$3,5 \dots U_B$ $0 \dots 0,5$	V V

The signal level (PLC or TTL) of the digital inputs can be set over the interface (see instruction manual).

Position control

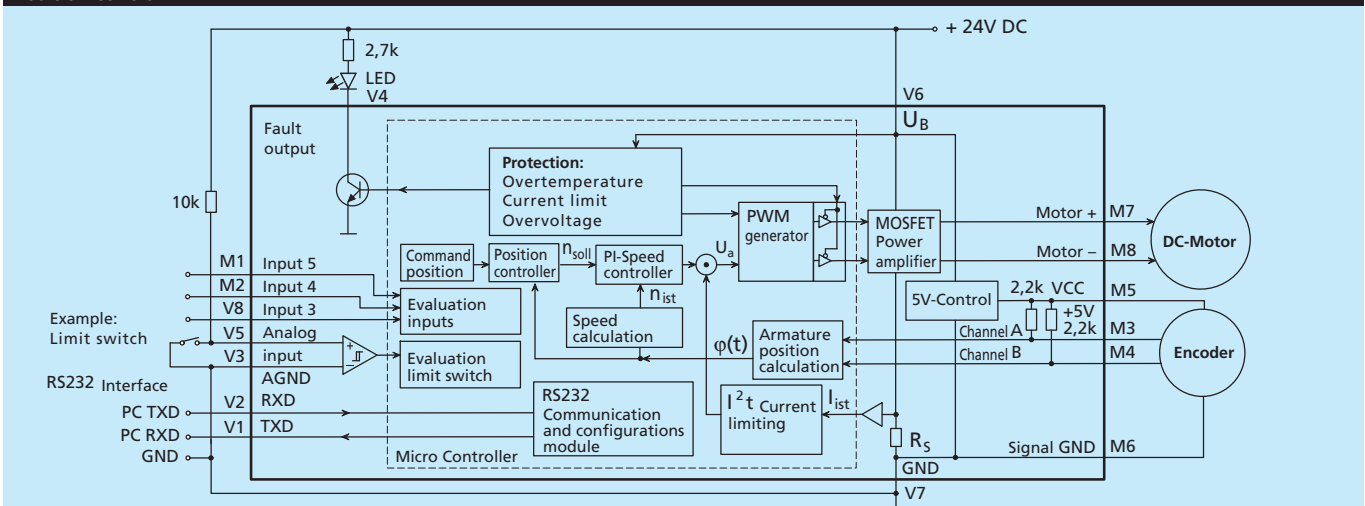

Motion Controller

General description

The MCDC 3003/06 S is the perfect controller for the entire range of FAULHABER DC-Micromotors. In conjunction with the proven IE2-512 encoders, they are capable of achieving a positioning resolution of 0.18°. A special ballast circuit protects the electronics from over-voltage during braking in generator mode.

Maximum performance:

- **PI speed controller** with superior performance specifications in respect of synchronous operation and minimal torque fluctuations.
- **Speed profiles** such as e.g. ramp, triangular or trapezoidal movements. More complex profiles can also be implemented.
- **Positioning** with high resolution, including **limit switches and zero referencing**.
- **Operation as torque controller** through current regulation.
- **Storage** and execution of motion programs for stand-alone positioning mode or to relieve the HOST computer.
- **Extended operating modes:**
 - Stepper motor mode
 - Gearing mode (electronic gear)
 - Analogue positioning mode (position control with analogue voltage)
 - Voltage regulator mode
 - Analogue target current presetting
 - IxR control

Latest technology in micro format:

- High efficiency
- Power amplifier with very high PWM frequency
- Power MOSFETs with minimal on-resistance
- Unique thermal protection device determines MOSFET silicon temperature
- High-capacity 16 bit signal processor

Versatile communication:

- **Set-point input** for speed presetting. Processes analogue and PWM signals. The input can also be used for a frequency or reference mark signal.
- **Error output** (Open Collector). Can also be programmed as a rotational direction or reference mark input.
- **Additional digital inputs**
- **RS232 interface** for connection to PC or control
- Operation of several drives on a single RS232 interface (Multiplex mode)

Programming made easy

An extensive ASCII command set is available for programming and operation. This can be preset from the PC, e.g. via any terminal program or via any other control computer.

Once programmed as a stepper motor, electronic gear or as speed / position controller via the analogue input, the drive can be operated independently of the RS232 interface.

For Windows operating systems the "FAULHABER Motion Manager" software is available. This considerably simplifies operation and configuration and also enables graphic online analysis of the operating data.

Fields of application

The Motion Controller can be used in many different areas. Thanks to the highly flexible connection options, this device is suitable for a diverse range of applications, for example in decentralised systems of automation technology, as well as in pick-and-place machines and machine tools.

Options

- Adapter for IE2 or HEDL encoder
- Serial null modem cable for RS232 interface
- Separate supply of motor and control electronics is optionally possible (important for safety-relevant applications); in this case the 3rd input is not required.
- Special preconfiguration of modes and parameters is possible on request.
- The "FAULHABER Motion Manager" software is available on request or on the Internet.

Note

A detailed instruction manual for installation and operation are provided with the Motion Manager.

Connection diagram

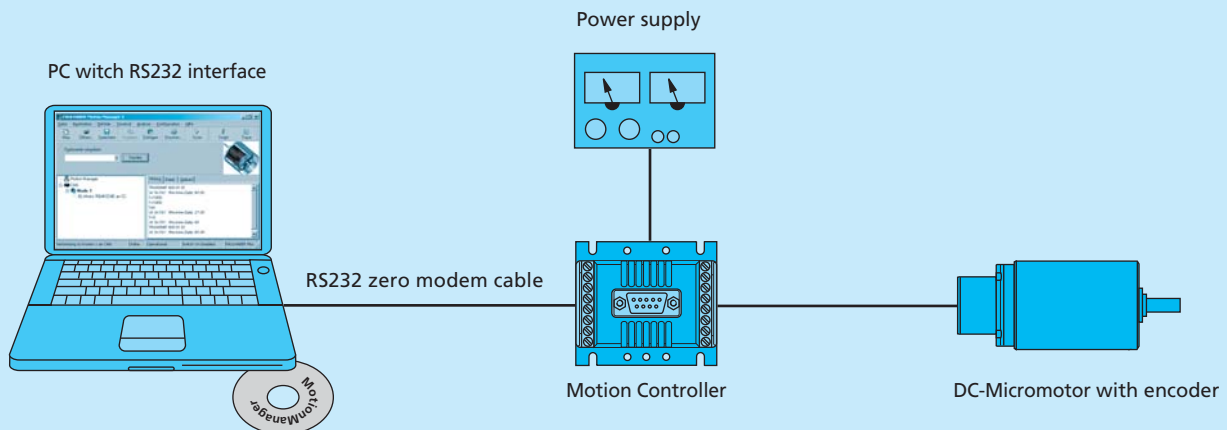

Dimensional drawing and connection information MCDC 3003 S

Scale reduced

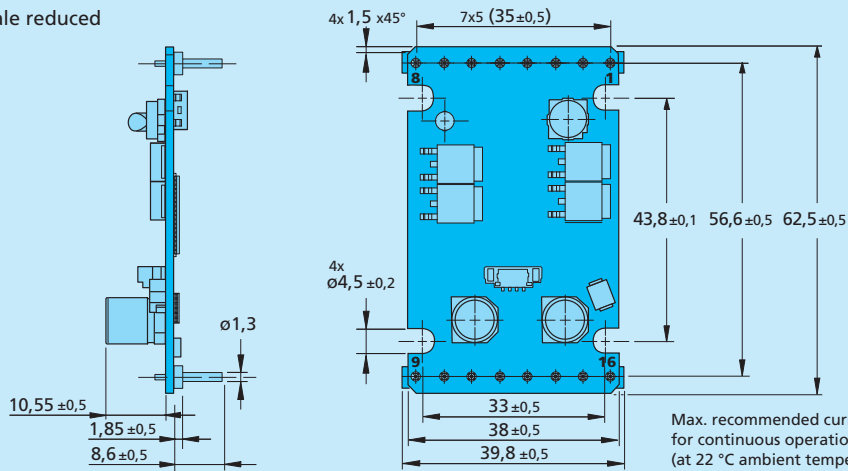

Max. recommended current
for continuous operation: 3A
(at 22 °C ambient temperature)
CAUTION: Thermal shutdown is
NOT guaranteed!

Connection

Pin	Function
1	5. In
2	4. In
3	Ch A
4	Ch B
5	+ 5V
6	SGND
7	Mot +
8	Mot -
9	TxD
10	RxD
11	AGND
12	Fault
13	AnIn
14	+ 24V
15	GND
16	3. In

Dimensional drawing and connection information MCDC 3006 S

Scale reduced

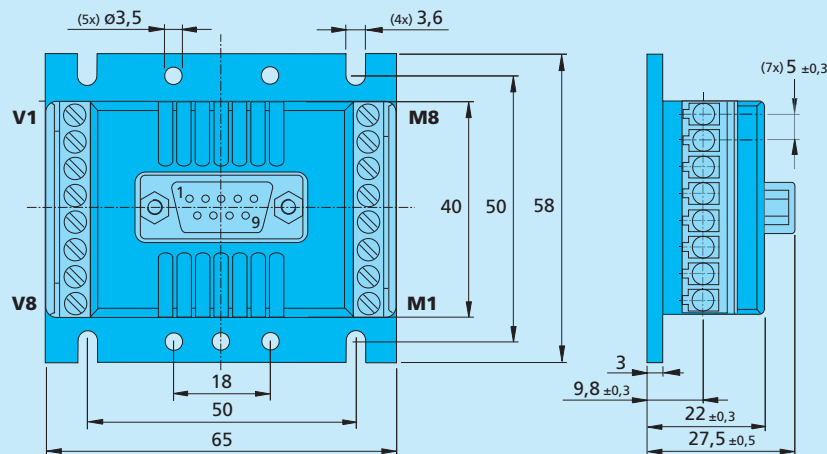

Motor connection

No.	Function
M1	5. In
M2	4. In
M3	Ch A
M4	Ch B
M5	+ 5V
M6	SGND
M7	Mot +
M8	Mot -

Supply connection

No.	Function
V1	TxD
V2	RxD
V3	AGND
V4	Fault
V5	AnIn
V6	+ 24V
V7	GND
V8	3. In

