

Encoders

Magnetic Encoders

Features:
 16 Lines per revolution
 2 Channels
 Digital output

Series IE2 – 16

		IE2 – 16	
Lines per revolution	N	16	
Signal output, square wave		2	channels
Supply voltage	V _{DD}	4 ... 18	V DC
Current consumption, typical (V _{DD} = 12 V DC)	I _{DD}	typ. 6, max. 12	mA
Output current, max. admissible	I _{OUT}	15	mA
Pulse width ²⁾	P	180 ± 45	°e
Phase shift, channel A to B ²⁾	Φ	90 ± 45	°e
Signal rise/fall time, max. (C _{LOAD} = 100 pF)	tr/tf	2,5 / 0,3	µs
Frequency range ¹⁾ , up to	f	7	kHz
Inertia of code disc	J	0,11	gcm ²
Operating temperature range		-25 ... +85	°C

¹⁾ Velocity (rpm) = f (Hz) x 60/N

²⁾ Tested at 2 kHz

Ordering information

Encoder type	number of channels	lines per revolution	in combination with:
IE2 – 16	2	16	DC-Micromotors series 1336 ... C, 1516 ... SR, 1524 ... SR, 1717 ... SR, 1724 ... SR, 1727 ... C, 2224 ... SR, 2232 ... SR, 2342 ... CR, 2642 ... CR, 2657 ... CR, 3242 ... CR, 3257 ... CR, 3863 ... C

Features

These incremental shaft encoders in combination with the FAULHABER DC-Micromotors are used for the indication and control of both shaft velocity and direction of rotation as well as for positioning.

The encoder is integrated in the DC-Micromotors SR-Series and extends the overall length by only 1,4 mm!

Solid state Hall sensors and a low inertia magnetic disc provide two channels with 90° phase shift.

The supply voltage for the encoder and the DC-Micromotor as well as the two channel output signals are interfaced through a ribbon cable with connector.

Details for the DC-Micromotors and suitable reduction gearheads are on separate catalogue pages.

Output signals / Circuit diagram / Connector information

Output signals

with clockwise rotation as seen from the shaft end

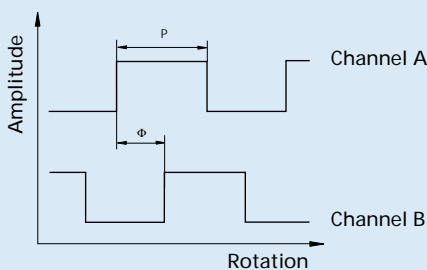

Admissible deviation of phase shift:

$$\Delta\Phi = \left| 90^\circ - \frac{\Phi}{P} * 180^\circ \right| \leq 45^\circ$$

Output circuit

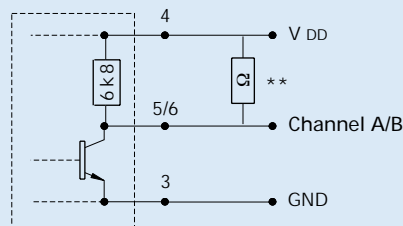

** An additional external pull-up resistor can be added to improve the rise time. Caution: I_{OUT} max. 15 mA must not be exceeded!

Pin Function

- 1 Motor - *
- 2 Motor + *
- 3 GND
- 4 V_{DD}
- 5 channel B
- 6 channel A

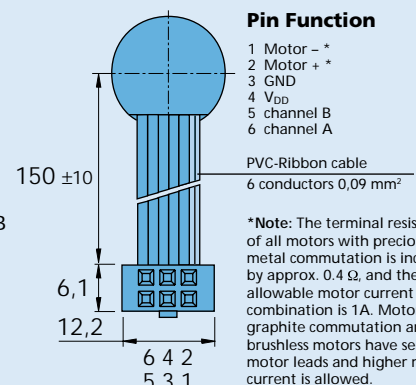

*Note: The terminal resistance of all motors with precious metal commutation is increased by approx. 0.4 Ω, and the max. allowable motor current in combination is 1A. Motors with graphite commutation and brushless motors have separate motor leads and higher motor current is allowed.

Connector
 DIN-41651
 grid 2,54 mm

DC-Micromotor 1336 U ... C - 123 with Encoder IE2 – 16 ... 512

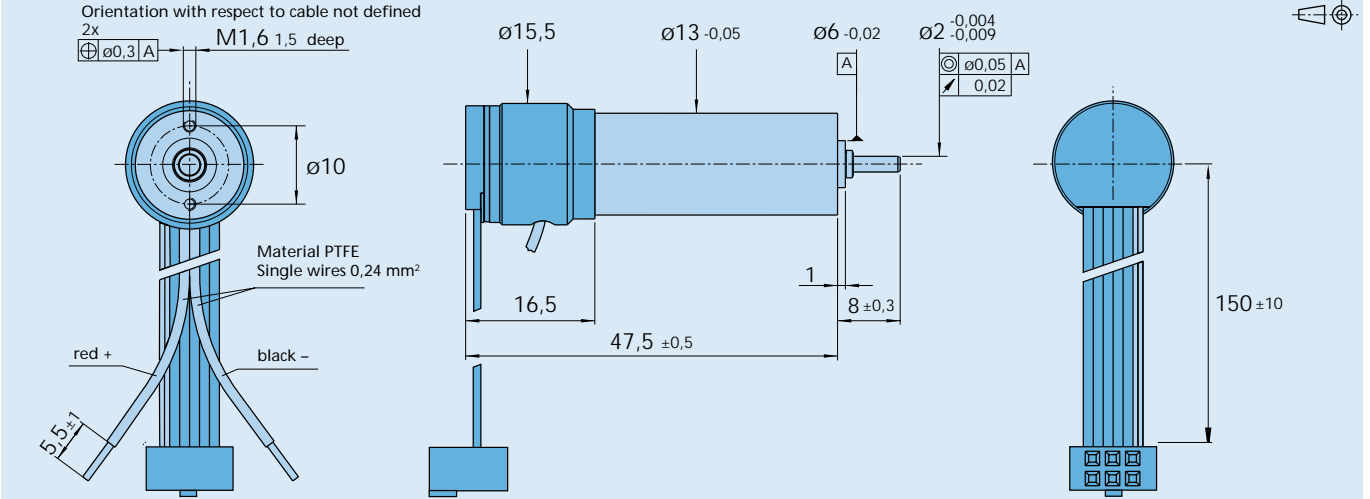

DC-Micromotor 1516 T ... SR with Encoder IE2 – 16 ... 512

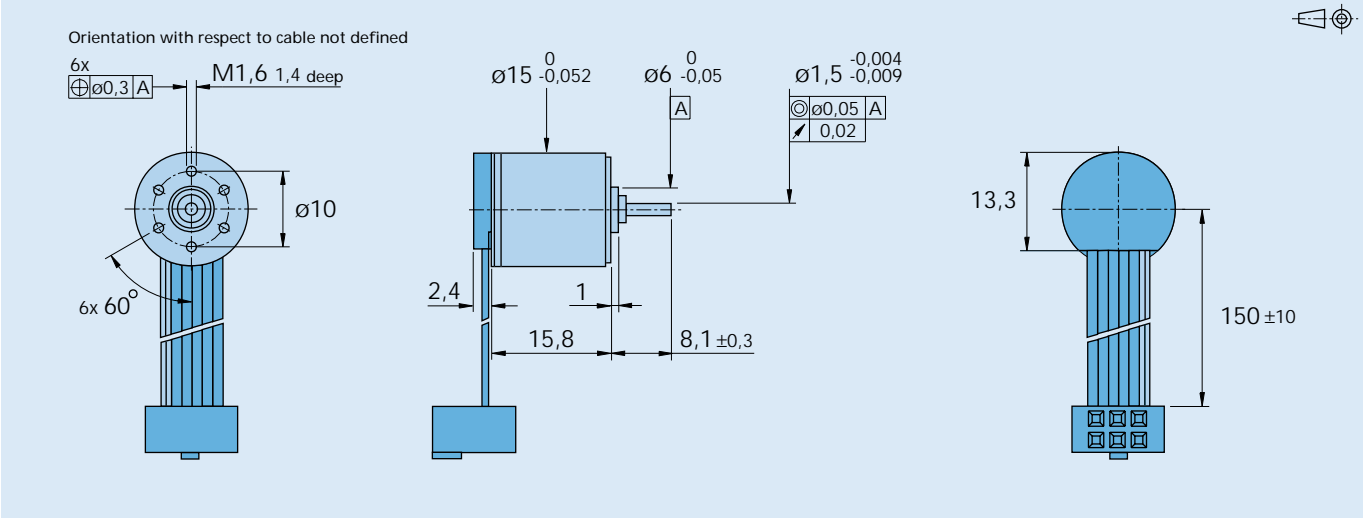

DC-Micromotor 1524 T ... SR with Encoder IE2 – 16 ... 512

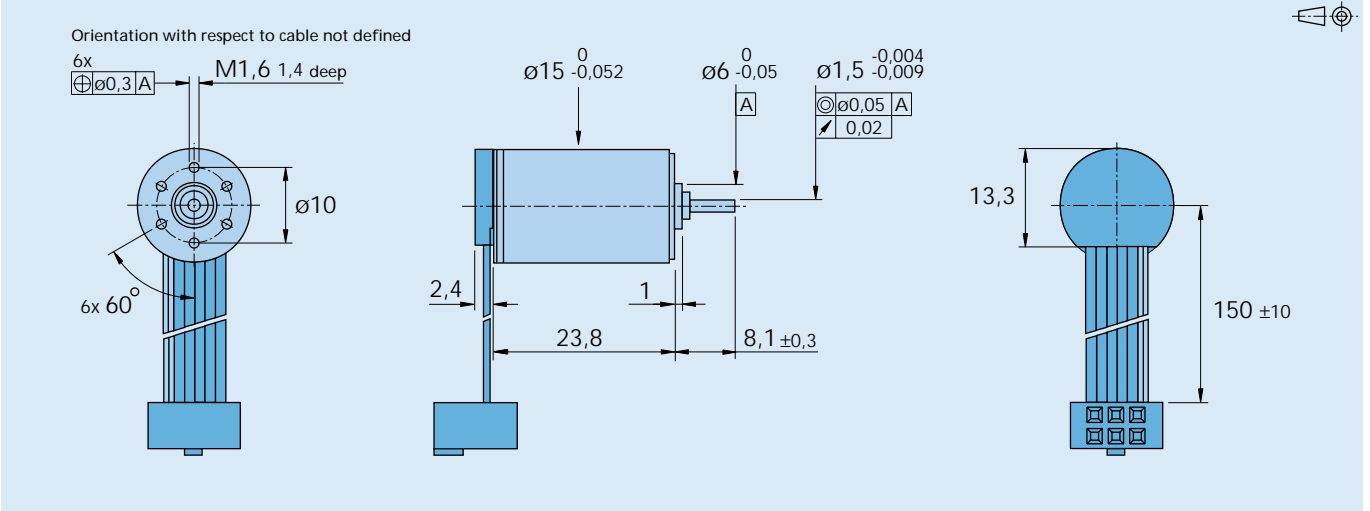

DC-Micromotor 1717 T ... SR with Encoder IE2 – 16 ... 512

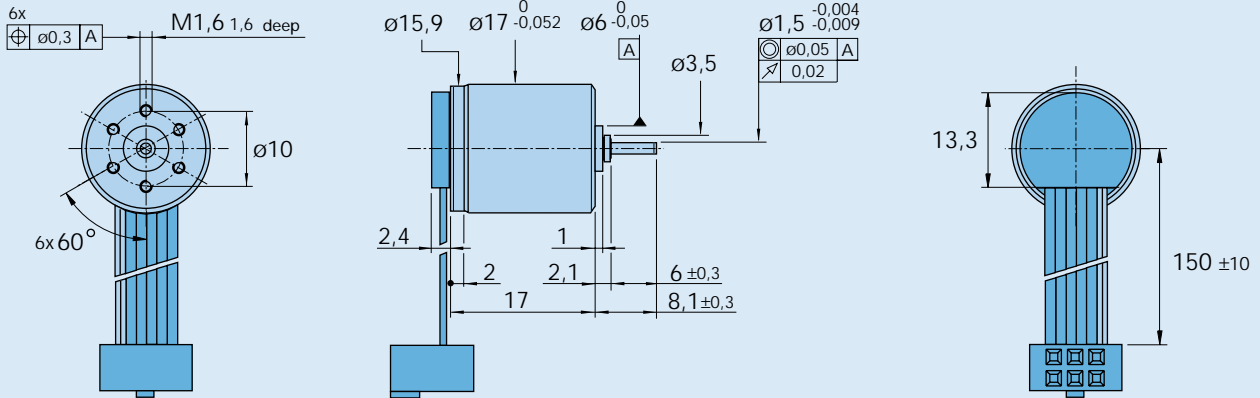

Orientation with respect to cable not defined

DC-Micromotor 1724 T ... SR with Encoder IE2 – 16 ... 512

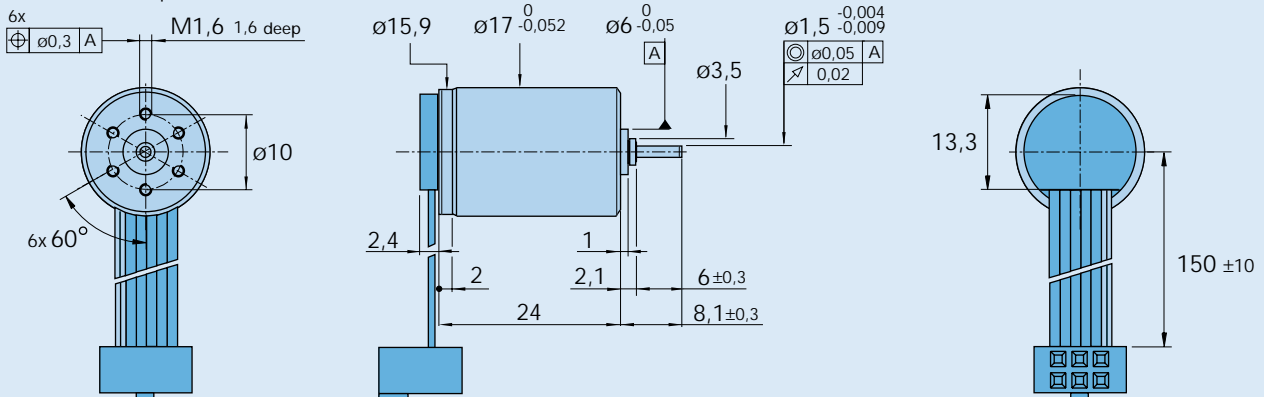
Orientation with respect to cable not defined

DC-Micromotor 1727 U ... C - 123 with Encoder IE2 – 16 ... 512

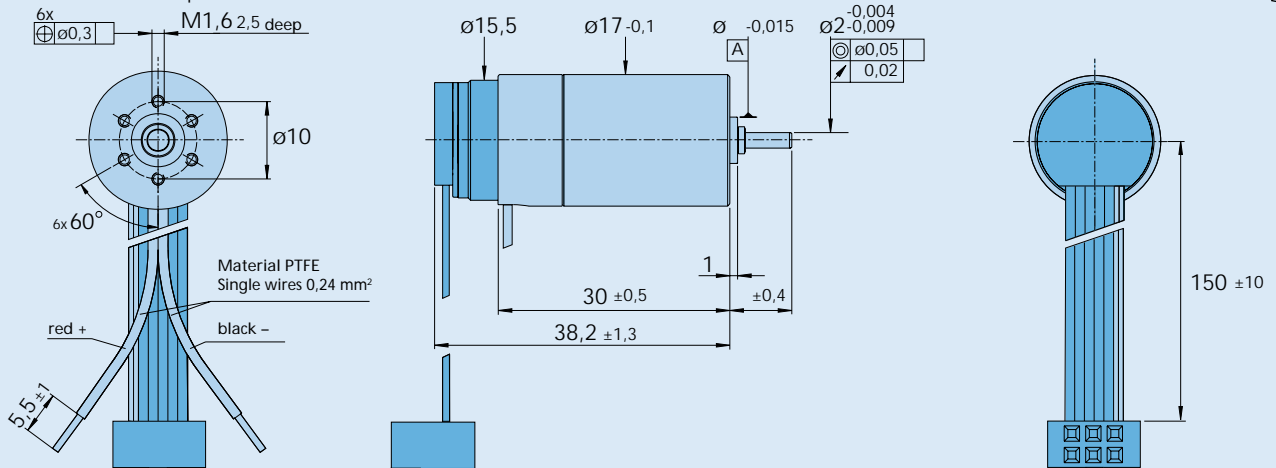
Orientation with respect to cable not defined



Brushless DC-Servomotor 2444 S ... B - K313 with with Encoder IE2 - 16 ... 512

