

Brushless DC-Motors

with integrated Drive Electronics

28 mNm

Series 3153 ... BRC

	3153 K	009 BRC	012 BRC	024 BRC	
Nominal voltage	U_N	9	12	24	Volt
No-load speed	n_0	5 200	5 200	5 200	rpm
No-load current (with shaft \varnothing 4,0 mm)	I_0	0,142	0,107	0,057	A
Starting torque	M_A	42	50	50	mNm
Torque constant	k_M	16,22	21,80	43,59	mNm/A
Slope of n-M curve	$\Delta n/\Delta M$	45,8	42,9	41,4	rpm/mNm
Rotor inertia	J	118	118	118	gcm ²
Operating temperature range		- 25 ... + 85			°C
Shaft bearings		ball bearings, preloaded			
Shaft load max.:					
– shaft diameter		4,0			mm
– radial at 3 000 rpm (3 mm from mounting face)		30			N
– axial at 3 000 rpm		5			N
– axial at standstill		50			N
Shaft play:					
– radial	\leq	0,015			mm
– axial	\parallel	0			mm
Housing material		mounting face in aluminium, housing in plastic			
Weight		155			g
Direction of rotation		reversible			

Recommended values - mathematically independent of each other

Speed range	n_e	1 000 – 6 500			rpm
Torque up to ¹⁾	$M_{e \max.}$	27	28	28	mNm
Current up to (thermal limits) ¹⁾	$I_{e \max.}$	1,90	1,46	0,75	A

¹⁾ Specification applies to $U_{nsoll} = 10$ V

Electronic

Supply voltage	U_p	min. 5 ... max. 30	V DC
Current	$I_{\max.}$	25	mA

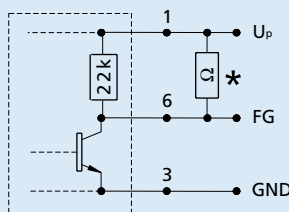

Circuit diagram

* An additional external pull-up resistor can be added to improve the rise time.

Caution:

$I_{OUT \max.}$ 15 mA must not be exceeded!

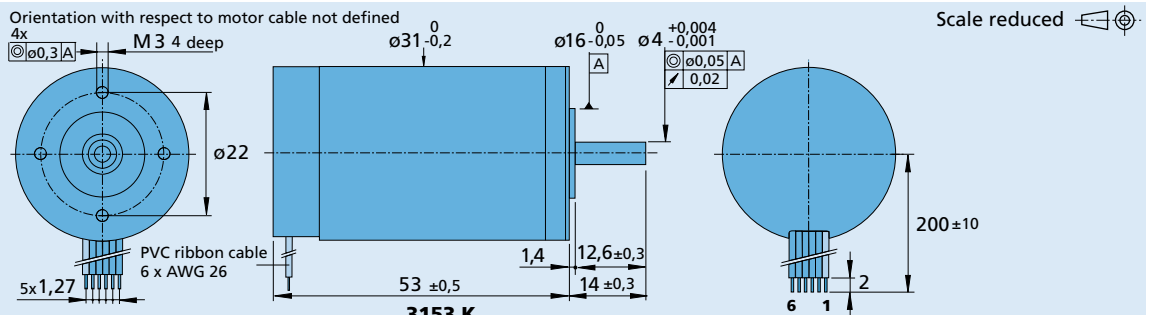

Cable connection

No.	Function	
1 (red)	U_p : electronic supply	5 V DC - 30 V DC
2	U_{mot} : coil supply	0 V DC up to 2 · U_N (max. 30 V DC)
3	GND : ground	
4	U_{rsoll} : Speed command	0 - 10 V DC > 10 V DC - max. U_p not defined
5	DIR : direction of rotation	on ground or $U < 0,5$ V = CCW, $U > 3$ V = CW
6	FG : frequency output	(max. U_p , $I_{\max.}$ 15 mA) 3 lines per revolution

Caution:

Incorrect lead connection will damage the motor electronics!