

Brushless DC-Servomotors

with integrated Encoder and Line Driver

4 Pole Technology

7 / 13 mNm

For combination with
Gearheads:
22F

Series 2232 ... BX4 IE3 L

	2232 S	012 BX4 S	024 BX4 S	012 BX4	024 BX4	IE3 L
1 Nominal voltage	U _N	12	24	12	24	Volt
2 Terminal resistance, phase-phase	R	3,5	12,4	3,5	12,4	Ω
3 Output power ^{1) 2)}	P _{2 max.}	4,4	4,5	8,8	8,9	W
4 Efficiency	η _{max.}	60,9	61,7	66,9	67,6	%
5 No-load speed	n ₀	13 200	14 000	6 600	7 000	rpm
6 No-load current (with shaft ø 3,0 mm)	I ₀	0,163	0,088	0,112	0,061	A
7 Stall torque	M _H	27,3	29,4	55,7	59,9	mNm
8 Friction torque, static	C ₀	0,6	0,6	0,85	0,85	mNm
9 Friction torque, dynamic	C _v	5,5 · 10 ⁻⁵	5,5 · 10 ⁻⁵	1,5 · 10 ⁻⁴	1,5 · 10 ⁻⁴	mNm/rpm
10 Speed constant	k _n	1 173	616	579	304	rpm/V
11 Back-EMF constant	k _E	0,852	1,623	1,728	3,288	mV/rpm
12 Torque constant	k _M	8,14	15,50	16,50	31,40	mNm/A
13 Current constant	k _I	0,123	0,065	0,061	0,032	A/mNm
14 Slope of n-M curve	Δn/ΔM	504	493	123	120	rpm/mNm
15 Terminal inductance, phase-phase	L	130	470	120	440	μH
16 Mechanical time constant	τ _m	22	22	6,7	6,5	ms
17 Rotor inertia	J	4,2	4,2	5,2	5,2	gcm ²
18 Angular acceleration	α _{max.}	65	70	107	115	· 10 ³ rad/s ²
19 Thermal resistance	R _{th 1} / R _{th 2}	2 / 13		2 / 13		K/W
20 Thermal time constant	τ _{w1} / τ _{w2}	4,1 / 274		4,1 / 283		s
21 Operating temperature range		- 40 ... + 85		- 40 ... + 85		°C
22 Shaft bearings		ball bearings, preloaded				
23 Shaft load max.:						
– radial at 3 000 rpm (4 mm from mounting flange)		20				N
– axial at 3 000 rpm		2				N
– axial at standstill		20				N
24 Shaft play:						
– radial	≤	0,015				mm
– axial	=	0				mm
25 Housing material		stainless steel				
26 Weight		81				g
27 Direction of rotation		electronically reversible				
28 Number of pole pairs		2				
Recommended values - mathematically independent of each other						
29 Speed up to ²⁾	n _{e max.}	16 700	16 700	10 500	10 500	rpm
30 Torque up to ^{1) 2)}	M _{e max.}	7	7	13	13	mNm
31 Current up to ^{1) 2)}	I _{e max.}	0,99	0,52	0,95	0,50	A

¹⁾ at 5 000 rpm

²⁾ thermal resistance R_{th 2} not reduced

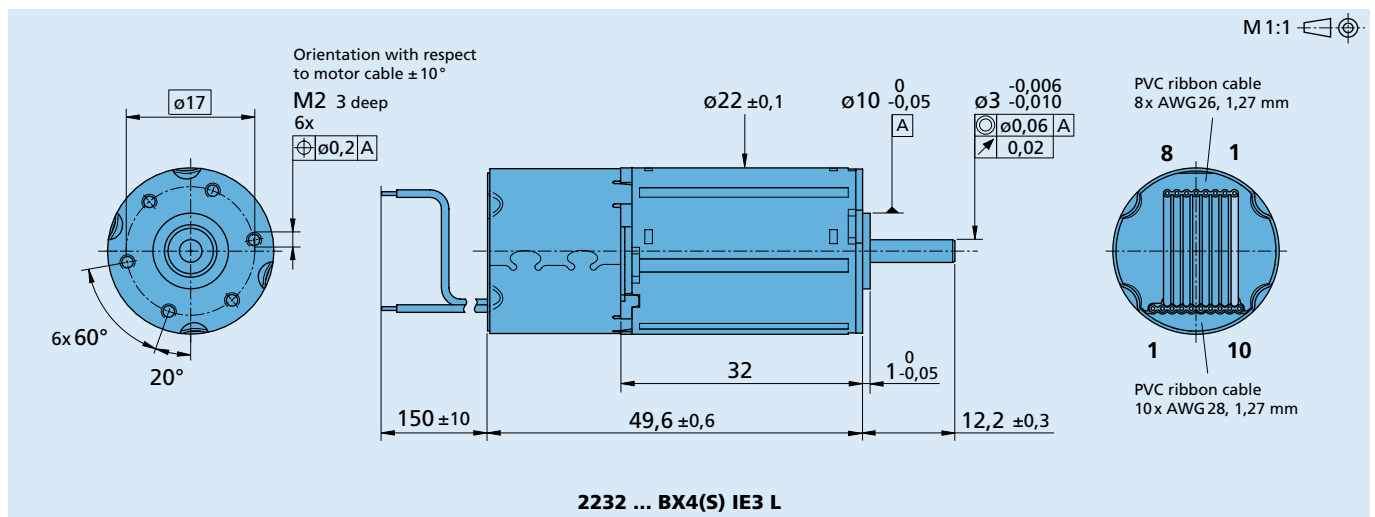

Magnetic Encoder		IE3-32 L	IE3-64 L	IE3-128 L	IE3-256 L	
Lines per revolution	N	32	64	128	256	
Frequency range ¹⁾ , up to	f	15	30	60	120	kHz
Signal output, square wave		2 + 1 index and complementary outputs				channels
Supply voltage	U _{DD Enc}	4,5 ... 5,5				V DC
Current consumption, typical ²⁾	I _{DD Enc}	typ. 17, max. 25				mA
Index Pulse width ³⁾	P ₀	90 ± 45				°e
Phase shift, channel A to B ³⁾	Φ	90 ± 45				°e
Inertia of encoder magnet	J	0,08				gcm ²

¹⁾ speed (rpm) = f (Hz) x 60/N

²⁾ U_{DD Enc} = 5 V: with unloaded outputs

³⁾ at 5 000 rpm

Notes: The output signals are TIA-422 compatible.

Examples of Line driver Receivers: ST26C32ABD (STM), ST26C32IP16 (EXAR), DS26C32AT (NSC).

Features

In this version, the brushless DC servomotors have an encoder with 3 output channels. A permanent magnet on the shaft creates a moving magnetic field which is captured using a single-chip angular sensor and further processed. At the encoder outputs, two 90° phase-shifted rectangular signals are available with up to 256 impulses and an index impulse per motor revolution.

The Line Driver version has differential signal outputs (TIA-422). Differential signals reduce ambient interference and are suitable for applications with high ambient interference. The line driver amplifies the encoder signal which means that long cables can be used without signal degradation. Differential signal outputs must be decoded by the appropriate receiver module.

The encoder is available in a variety of different resolutions and is suitable for speed control and positioning applications. The motor and encoder cables are connected via separate ribbon cables.

A detailed instruction manual is included with the product or is available online at www.faulhaber.com

Options

- Connector variants

Encoder:
AWG 28 / PVC ribbon cable (10-conductors), with connector DIN-41651 (pitch 2,54 mm)

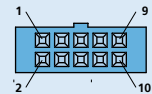

Motor:
AWG 26 / PVC ribbon cable (8-conductors), with connector MicroFit



Full product description

- Examples:
2232S024BX4 IE3-256 L
2232S012BX4S IE3-32 L

Output signals / Circuit diagram / Connector information

Output signals
with clockwise rotation as seen from the shaft end

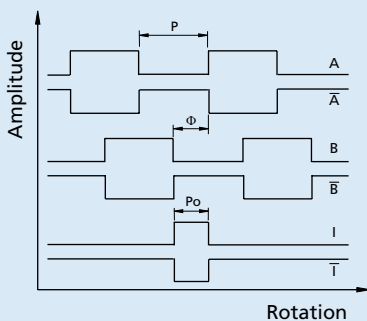

Admissible deviation of phase shift/Index pulse:

$$\Delta\Phi = \left| 90^\circ - \frac{\Phi}{P} * 180^\circ \right| \leq 45^\circ \quad \Delta P_0 = \left| 90^\circ - \frac{P_0}{P} * 180^\circ \right| \leq 45^\circ$$

Output circuit

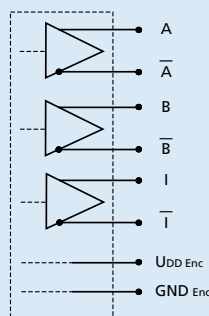

Connection Motor

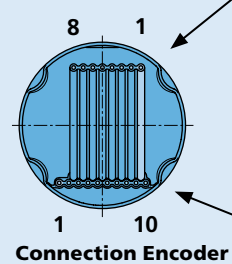

No.	Function
1	Phase C
2	Phase B
3	Phase A
4	GND
5	U _{DD} (2,2 ... 18V DC)
6	Hall sensor C
7	Hall sensor B
8	Hall sensor A

No.	Function
1	n.c.
2	U _{DD Enc}
3	GND Enc
4	n.c.
5	Channel Ā
6	Channel A
7	Channel B̄
8	Channel B
9	Channel Ī (Index)
10	Channel I (Index)

Caution:
Incorrect lead connection will damage the motor electronics!