

# Brushless DC-Motors

with integrated Drive Electronics

1,8 mNm

## Series 1525 ... BRC

	1525 U	009 BRC	012 BRC	015 BRC	
Nominal voltage	$U_N$	9	12	15	Volt
No-load speed	$n_0$	16 300	15 800	15 500	rpm
No-load current (with shaft $\varnothing$ 2,0 mm)	$I_0$	0,047	0,037	0,033	A
Starting torque	$M_A$	3,9	4,1	4,1	mNm
Torque constant	$k_M$	5,12	7,06	8,95	mNm/A
Slope of n-M curve	$\Delta n/\Delta M$	2 540	2 260	2 270	rpm/mNm
Rotor inertia	J	2,2	2,2	2,2	gcm <sup>2</sup>
Operating temperature range		- 25 ... + 85			°C
Shaft bearings		ball bearings, preloaded			
Shaft load max.:					
- shaft diameter		2,0			mm
- radial at 3 000 rpm (3 mm from mounting face)		8			N
- axial at 3 000 rpm		0,8			N
- axial at standstill		10			N
Shaft play:					
- radial	$\perp$	0,015			mm
- axial	$\parallel$	0			mm
Housing material		mounting face in aluminium, housing in plastic			
Weight		16			g
Direction of rotation		reversible			

### Recommended values - mathematically independent of each other

		1 000 – 16 000			
Speed range	$n_e$				rpm
Torque up to <sup>1)</sup>	$M_{e \max.}$	1,7	1,8	1,8	mNm
Current up to (thermal limits) <sup>1)</sup>	$I_{e \max.}$	0,40	0,31	0,25	A

<sup>1)</sup> Specification applies to  $U_{\text{nsoll}} = 10 \text{ V}$

### Electronic

Supply voltage	$U_p$	min. 4 ... max. 18	V DC
Current	$I_{\max.}$	15	mA

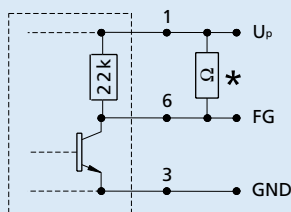

#### Circuit diagram

\* An additional external pull-up resistor can be added to improve the rise time.

#### Caution:

$I_{\text{out max.}}$  15 mA must not be exceeded!

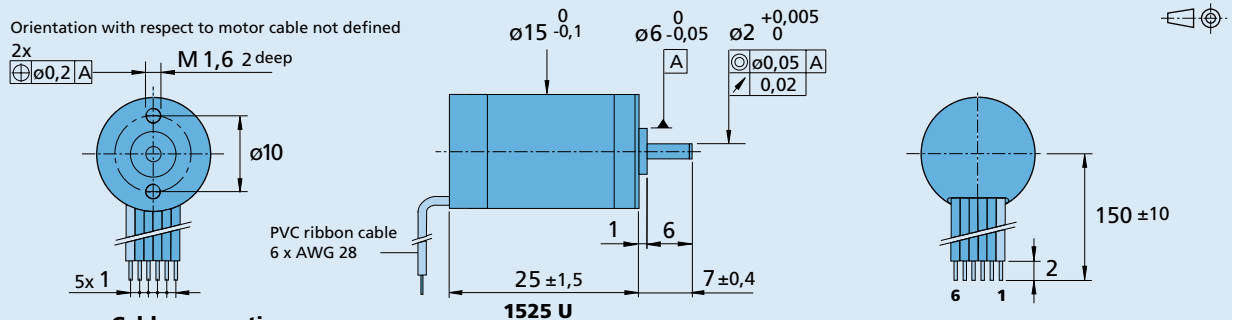

#### Cable connection

No.	Function	
1 (red)	$U_p$ : electronic supply	4 V DC - 18 V DC
2	$U_{\text{mot}}$ : coil supply	1,7 V DC - 18 V DC
3	GND : ground	
4	$U_{\text{nsoll}}$ : Speed command	0 - 10 V DC   > 10 V DC - max. $U_p$ not defined
5	DIR : direction of rotation	on ground or $U < 0,5 \text{ V} = \text{CCW}$ , $U > 3 \text{ V} = \text{CW}$
6	FG : frequency output	(max. $U_p$ , $I_{\max.}$ 15 mA) 3 lines per revolution

#### Caution:

Incorrect lead connection will damage the motor electronics!