

NEW



Motion Controller

4-Quadrant PWM
with RS232 interface

For combination with:
Linear DC-Servomotors
with analogue Hall sensors

Series MCLM 3003/06 S

		MCLM 3003 S	MCLM 3006 S	
Power supply	U _B	12 ... 30	12 ... 30	V DC
PWM switching frequency	f _{PWM}	78,12	78,12	kHz
Efficiency	η	95	95	%
Max. continuous output current ¹⁾	I _{dauer}	3	6	A
Max. peak output current	I _{max}	10	10	A
Total standby current	I _{el}	0,06	0,06	A
Speed range		1 ... 10 000	1 ... 10 000	mm/s
Scanning rate	N	100	100	μs
Encoder resolution with Hall Sensors ²⁾		≤ 3 000	≤ 3 000	lines/τ _m
Resolution with external encoder ²⁾		≤ 65 535	≤ 65 535	lines/τ _m
Input/output (partially free configurable)		3	3	
Program memory:				
– memory size		3,3	3,3	kWord
– Number of instructions		ca. 1 000	ca. 1 000	instructions
Operating temperature range		0 ... + 70	0 ... + 70	°C
Storage temperature		– 25... + 85	– 25 ... + 85	°C
Housing material		without housing	aluminium, black anodized	
Weight		18	160	g

¹⁾ at 22°C ambient temperature

²⁾ τ_m is the polar pitch of the linear motor

Connection information

Connection "TxD", "RxD":				
Interface			RS232	
Communication profile			Faulhaber - ASCII	
Max. transfer speed rate			115 200	baud
Connection "AGND":				
– analog ground			analog GND	
– digital input	external encoder		channel B	
	R _{In}		10	kΩ
	f		≤ 400	kHz
Connection "Fault":				
– digital input	R _{In}		100	kΩ
– digital output (open collector)	U		≤ U _B	V
	I		≤ 30	mA
	clear		switched to GND	
	set		high-impedance	
	fault output	no error	switched to GND	
		error	high-impedance	
	signal output	f	≤ 2	kHz
	resolution		1...255	lines/τ _m
Connection "AnIn":				
– analog input	set position value	U _{In}	± 10	V
– digital input	external encoder		channel A	
		f	≤ 400	kHz
	step frequency input	f	≤ 400	kHz
		R _{In}	5	kΩ
Connection "+24V":				
	U _B		12 ... 30	V DC
Connection "GND":				
			ground	
Connection "3. In":				
– digital input	R _{In}		22	kΩ
– electronic supply voltage ³⁾	U _B		12 ... 30	V DC

³⁾ Optional on request

Connection information

Connection "Ph A", "Ph B", "Ph C":					
Motor connection	Ph A		Phase A	brown ¹⁾	
	Ph B		Phase B	orange ¹⁾	
	Ph C		Phase C	yellow ¹⁾	
		U_{out}	$0 \dots U_B$		V
PWM switching frequency		f_{PWM}	78,12		kHz
Connection "Hall A", "Hall B", "Hall C":					
Hall sensor input	Hall A		Hall sensor A	green ¹⁾	
	Hall B		Hall sensor B	blue ¹⁾	
	Hall C		Hall sensor C	grey ¹⁾	
		U_{in}	≤ 5		V
Connection "SGND":					
Signal GND			Signal ground	black ¹⁾	
Connection "+5V":					
Output voltage for external use ²⁾		U_{out}	5	red ¹⁾	V DC
Load current		I_{out}	≤ 60		mA

¹⁾ Color identification for linear DC-Servomotor

²⁾ E.g. Hall sensor

D-SUB-connector information

Connection D-SUB-connector:			
Pin 2	RxD		RS232 / RxD
Pin 3	TxD		RS232 / TxD
Pin 5	GND		Ground

Digital inputs general information

- PLC, default	high	$12,5 \dots U_B$	V
	low	$0 \dots 7$	V
- TTL	high	$3,5 \dots U_B$	V
	low	$0 \dots 0,5$	V

The signal level (PLC or TTL) of the digital inputs can be set over the interface (see instruction manual).

Position control

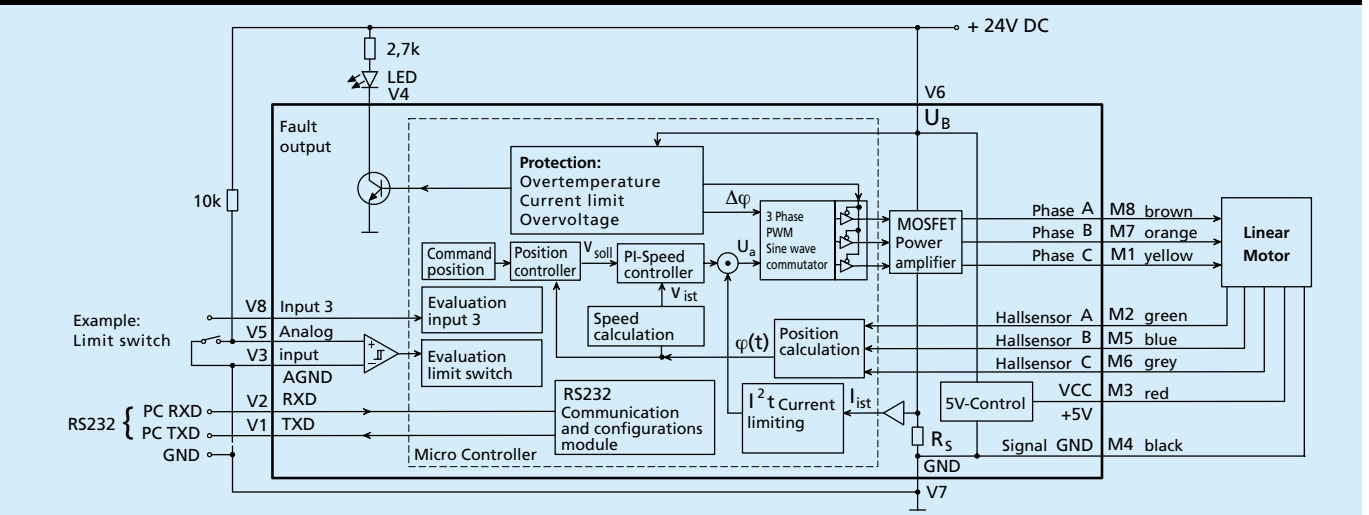

Specifications subject to change without notice

Motion Controller

General description

The MCLM 3003/06 S is designed for linear DC-Servomotors with analogue Hall sensors. Ultra-low speeds and high positioning resolutions (1/3000 polar pitch) are thus possible without the need for an additional encoder. The motors have a sinusoidal current, resulting in a constant force over the entire stroke. This means that the motors move particularly quietly, and efficiency is also increased.

Maximum performance:

- **PI speed controller** with superior performance specifications in respect of synchronous operation and minimal force fluctuations.
- **Speed profiles** such as e.g. ramp, triangular or trapezoidal movements. More complex profiles can also be implemented.
- **Positioning** with high resolution, including **limit switches and zero referencing**.
- **Operation as force controller** through current regulation.
- **Storage** and execution of motion programs for stand-alone positioning mode or to relieve the HOST computer.
- **Extended operating modes:**
 - Stepper motor mode
 - Gearing mode (electronic gear)
 - Analogue positioning mode (position control with analogue voltage)
 - Analogue target current presetting
 - External encoder to determine actual position

Latest technology in micro format:

- High efficiency
- Power amplifier with very high PWM frequency
- Power MOSFETs with minimal on-resistance
- Unique thermal protection device determines MOSFET silicon temperature
- High-capacity 16 bit signal processor

Versatile communication:

- **Set-point input** for speed presetting. Processes analogue and PWM signals. The input can also be used for a frequency or reference mark signal.
- **Fault:** error output (Open Collector). Can also be programmed as digital input for shaft direction or reference mark.
- **Additional digital input**
- **RS232 interface** for connection to PC or control
- Operation of several drives on a single RS232 interface (Multiplex mode)

Programming made easy

An extensive ASCII command set is available for programming and operation. This can be preset from the PC, e.g. via any terminal program or via any other control computer.

Once programmed as a stepper motor, electronic gear or as speed / position controller via the analogue input, the drive can be operated independently of the RS-232 interface.

For Windows operating systems the "FAULHABER Motion Manager" software is available free of charge. This considerably simplifies operation and configuration and also enables graphic online analysis of the operating data.

Fields of application

The Motion Controller can be used in many different areas. Thanks to the highly flexible connection options, this device is suitable for a diverse range of applications, for example in decentralised systems of automation technology, as well as in pick-and-place machines and machine tools.

Options

- Serial null modem cable for RS232 interface
- Separate supply of motor and control electronics is optionally possible (important for safety-relevant applications); in this case the 3rd input is not available.
- Special preconfiguration of modes and parameters is possible on request.
- The "FAULHABER Motion Manager" software is available on request or on the Internet free of charge.

Note

A detailed instruction manual for installation and operation are provided with the Motion Manager.

Connection diagram for Multiplex mode and configuration with PC / PLC

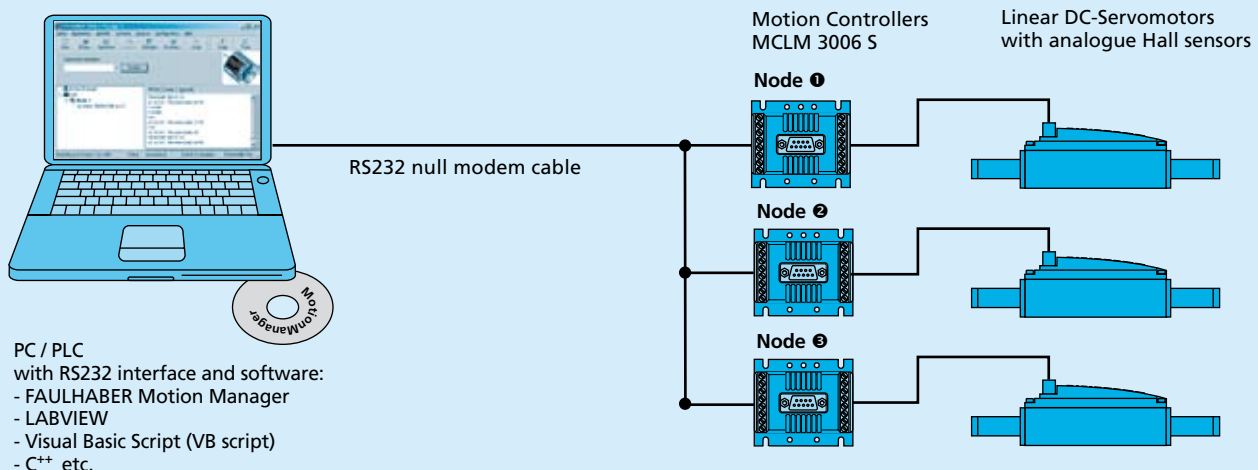

Specifications subject to change without notice

Connection for stand-alone application

Analog input voltage

- Position control
- Target current set

Digital inputs

- Limit switch
- Stepper mode
- Start program
- External encoder

Digital outputs

- Error output
- Signal output

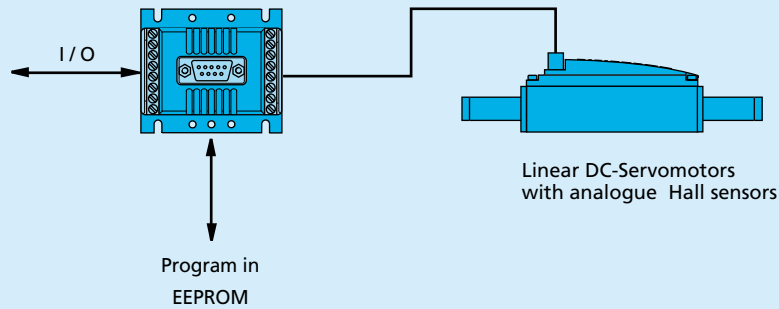

Linear DC-Servomotors with analogue Hall sensors

Dimensional drawing and connection information MCLM 3003 S

Scale reduced

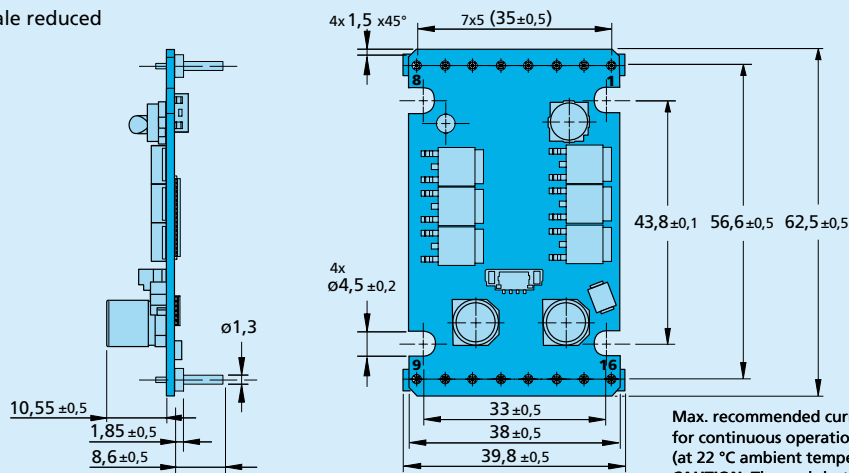

Max. recommended current for continuous operation: 3A (at 22 °C ambient temperature)
CAUTION: Thermal shutdown is NOT guaranteed!

Connection

Pin	Function
1	Ph C
2	Hall A
3	+ 5V
4	SGND
5	Hall B
6	Hall C
7	Ph B
8	Ph A
9	TxD
10	RxD
11	AGND
12	Fault
13	AnIn
14	+ 24V
15	GND
16	3. In

Dimensional drawing and connection information MCLM 3006 S

Scale reduced

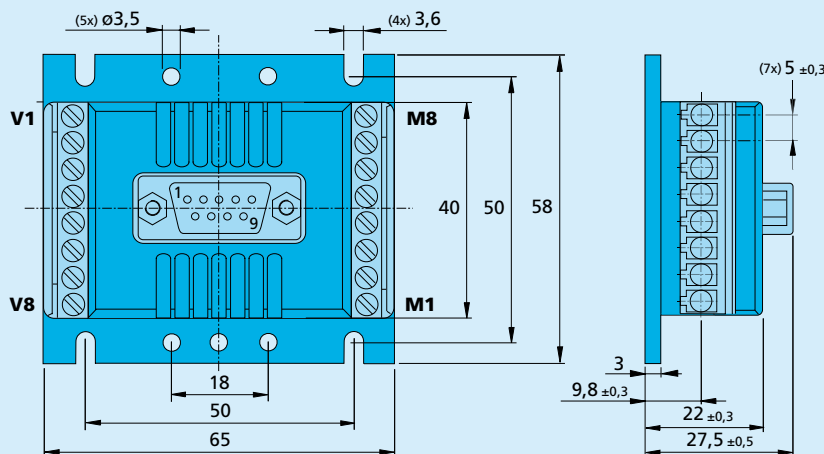

Motor connection

No.	Function
M1	Ph C
M2	Hall A
M3	+ 5V
M4	SGND
M5	Hall B
M6	Hall C
M7	Ph B
M8	Ph A

Supply connection

No.	Function
V1	TxD
V2	RxD
V3	AGND
V4	Fault
V5	AnIn
V6	+ 24V
V7	GND
V8	3. In