

**NEW**

# Motion Controller

4-Quadrant PWM  
with CAN interface

For combination with:  
Linear DC-Servomotors  
with analogue Hall sensors

## Series MCLM 3003/06 C

		MCLM 3003 C	MCLM 3006 C	
Power supply	U <sub>B</sub>	12 ... 30	12 ... 30	V DC
PWM switching frequency	f <sub>PWM</sub>	78,12	78,12	kHz
Efficiency	η	95	95	%
Max. continuous output current <sup>1)</sup>	I <sub>dauer</sub>	3	6	A
Max. peak output current	I <sub>max</sub>	10	10	A
Total standby current	I <sub>el</sub>	0,06	0,06	A
Speed range		1 ... 10 000	1 ... 10 000	mm/s
Scanning rate	N	100	100	μs
Encoder resolution with Hall Sensors <sup>2)</sup>		≤ 3 000	≤ 3 000	lines/τ <sub>m</sub>
Resolution with external encoder <sup>2)</sup>		≤ 65 535	≤ 65 535	lines/τ <sub>m</sub>
Input/output (partially free configurable)		3	3	
Operating temperature range		0 ... + 70	0 ... + 70	°C
Storage temperature		- 25... + 85	- 25 ... + 85	°C
Housing material		without housing	aluminium, black anodized	
Weight		18	160	g

<sup>1)</sup> at 22°C ambient temperature

<sup>2)</sup> τ<sub>m</sub> is the polar pitch of the linear motor

### Connection information

<b>Connection "CANH", "CANL":</b>			CAN-High / CAN-Low	
Interface			CAN	
Communication profile			CANopen	
Max. transfer speed rate			1	Mbit/s
<b>Connection "AGND":</b>				
- analog ground			analog GND	
- digital input external encoder			channel B	
	R <sub>in</sub>	10		kΩ
	f	≤ 400		kHz
<b>Connection "Fault":</b>				
- digital input		R <sub>in</sub>	100	kΩ
- digital output (open collector)		U	≤ U <sub>B</sub>	V
	I		≤ 30	mA
	clear		switched to GND	
	set		high-impedance	
	fault output	no error	switched to GND	
		error	high-impedance	
	signal output	f	≤ 2	kHz
	resolution		1...255	lines/τ <sub>m</sub>
<b>Connection "AnIn":</b>			"AGND" as GND	
- analog input set position value		U <sub>in</sub>	± 10	V
- digital input external encoder			channel A	
	f		≤ 400	kHz
	step frequency input	f	≤ 400	kHz
	R <sub>in</sub>		5	kΩ
<b>Connection "+24V":</b>		U <sub>B</sub>	12 ... 30	V DC
<b>Connection "GND":</b>			ground	
<b>Connection "3. In":</b>				
- digital input		R <sub>in</sub>	22	kΩ
- electronic supply voltage <sup>3)</sup>		U <sub>B</sub>	12 ... 30	V DC

<sup>3)</sup> Optional on request

**Connection information**
**Connection "Ph A", "Ph B", "Ph C":**

Motor connection	Ph A		Phase A	brown <sup>1)</sup>	
	Ph B		Phase B	orange <sup>1)</sup>	
	Ph C		Phase C	yellow <sup>1)</sup>	
		$U_{Out}$	$0 \dots U_B$		V
PWM switching frequency		$f_{PWM}$	78,12		kHz

**Connection "Hall A", "Hall B", "Hall C":**

Hall sensor input	Hall A		Hall sensor A	green <sup>1)</sup>	
	Hall B		Hall sensor B	blue <sup>1)</sup>	
	Hall C		Hall sensor C	grey <sup>1)</sup>	
		$U_{In}$	$\leq 5$		V

**Connection "SGND":**

Signal GND			Signal ground	black <sup>1)</sup>	
------------	--	--	---------------	---------------------	--

**Connection "+5V":**

Output voltage for external use <sup>2)</sup>		$U_{Out}$	5	red <sup>1)</sup>	V DC
Load current		$I_{Out}$	$\leq 60$		mA

<sup>1)</sup> Color identification for linear DC-Servomotor

<sup>2)</sup> E.g. Hall sensor

**D-SUB-connector information**
**Connection D-SUB-connector:**

Pin 2	CAN_L		CAN-Low	
Pin 3	GND		Ground	
Pin 7	CAN_H		CAN-High	

**Digital inputs general information**

- PLC, default	high	$12,5 \dots U_B$	V
	low	$0 \dots 7$	V
- TTL	high	$3,5 \dots U_B$	V
	low	$0 \dots 0,5$	V

The signal level (PLC or TTL) of the digital inputs can be set over the interface (see instruction manual).

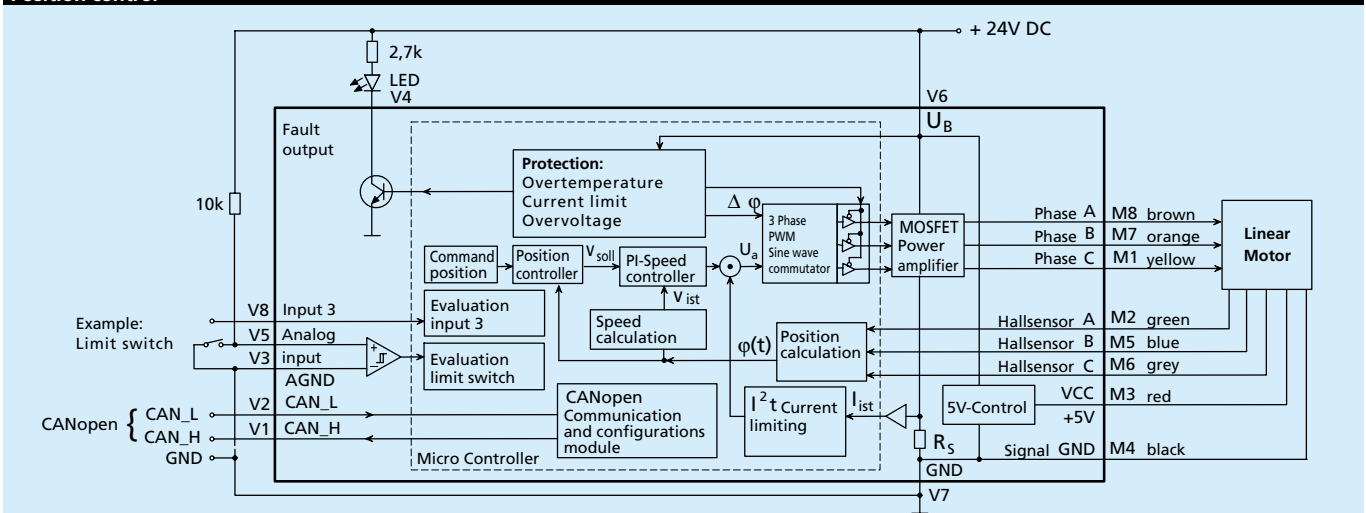
**Position control**

 Specifications subject to change without notice  
 Available, spring 2008  
[www.faulhaber.com](http://www.faulhaber.com)

## Motion Controller

### General description

The MCLM 3003/06 C is designed for linear DC-Servomotors with analogue Hall sensors. Ultra-low speeds and high positioning resolutions (1/3000 pole pitch) are thus possible without the need for an additional encoder. The motors have a sinusoidal current, resulting in a constant force over the entire stroke. This means that the motors moves particularly quietly, and efficiency is also increased.

### Maximum performance:

- **PI speed controller** with superior performance specifications in respect of synchronous operation and minimal force fluctuations.
- **Speed profiles** such as e.g. ramp, triangular or trapezoidal movements. More complex profiles can also be implemented.
- **Positioning** with high resolution, including **limit switches and zero referencing**.
- **Operation as force controller** through current regulation.
- **Extended operating modes:**
  - Stepper motor mode
  - Gearing mode (electronic gear)
  - Analogue positioning mode (position control with analogue voltage)
  - Analogue target current presetting
  - External encoder to determine actual position

### Latest technology in micro format:

- High efficiency
- Power amplifier with very high PWM frequency
- Power MOSFETs with minimal on-resistance
- Unique thermal protection device determines MOSFET silicon temperature
- High-capacity 16 bit signal processor

### Versatile communication:

- **Set-point input** for speed presetting. Processes analogue and PWM signals. The input can also be used for a frequency or reference mark signal.
- **Fault:** error output (Open Collector). Can also be programmed as digital input for shaft direction or reference mark.
- **Additional digital input**
- **CANopen interface** for integration into a CAN network with transfer rates up to 1Mbit/s

### Programming made easy

The MCLM 3003/06 C supports the CANopen communication profile according to DS301 V4.02 and DSP402 V2.0 in accordance with the CiA specification for slave devices with the following services:

- 1 Server SDO
- 3 Transmit PDOs, 3 Receive PDOs
- Static PDO Mapping
- NMT with Node Guarding
- Emergency Object

The transfer rate and node no. are set via the network in accordance with the LSS protocol according to DSP305 V1.11, and automatic baud rate detection is also implemented. In addition, all functions and parameters of the drive unit can be very easily activated via a special FAULHABER PDO channel. For each FAULHABER command a corresponding CAN message frame is available on the PDO channel, enabling the CAN unit to be operated analogously to the serial variant.

For Windows operating systems the **"FAULHABER Motion Manager"** software is available free of charge. This considerably simplifies operation and configuration and also enables graphic online analysis of the operating data.

### Fields of application

The Motion Controller can be used in many different areas. Thanks to the highly flexible connection options, this device is suitable for a diverse range of applications, for example in decentralised systems of automation technology, as well as in pick-and-place machines and machine tools.

### Options

- Separate supply of motor and control electronics is optionally possible (important for safety-relevant applications); in this case the 3rd input is not available.
- Special preconfiguration of modes and parameters is possible on request.
- The **"FAULHABER Motion Manager"** software is available on request or on the Internet free of charge.

### Note

A detailed instruction manual for installation and operation are provided with the Motion Manager.

## Connection diagram for easy configuration with PC

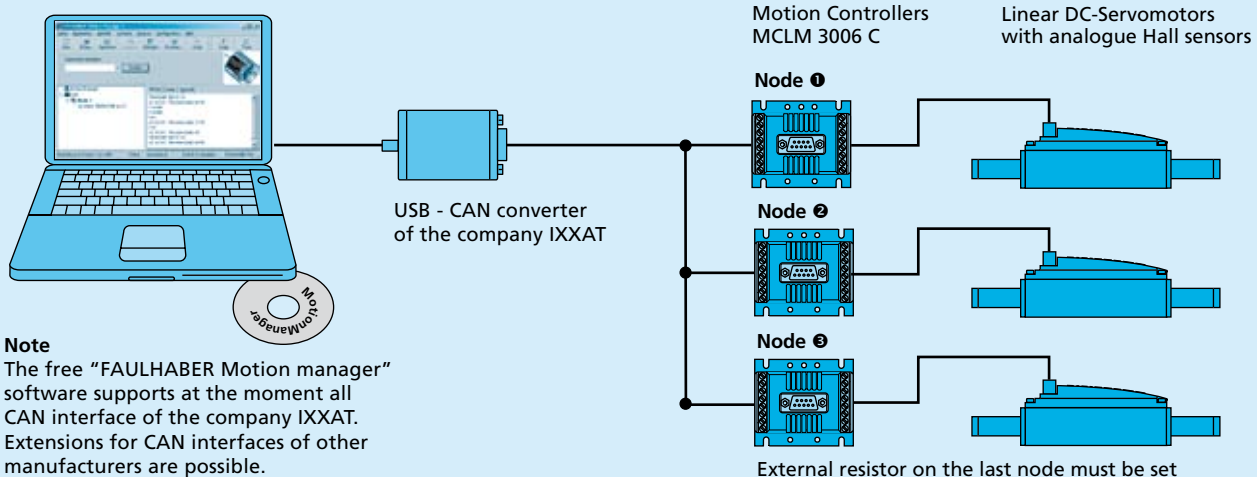

### Note

The free **"FAULHABER Motion manager"** software supports at the moment all CAN interface of the company IXXAT. Extensions for CAN interfaces of other manufacturers are possible.

### Connection for CANopen network

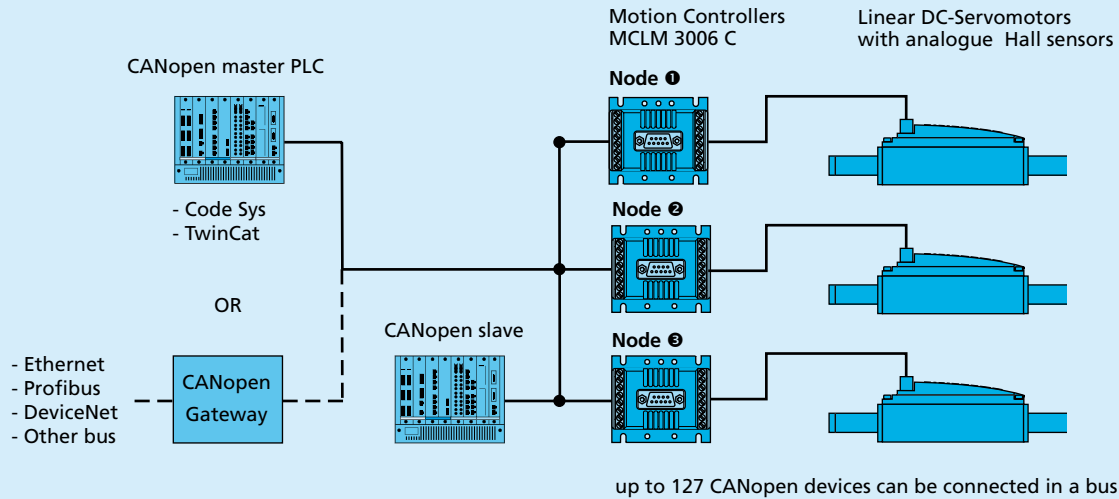

### Dimensional drawing and connection information for MCLM 3003 C

Scale reduced

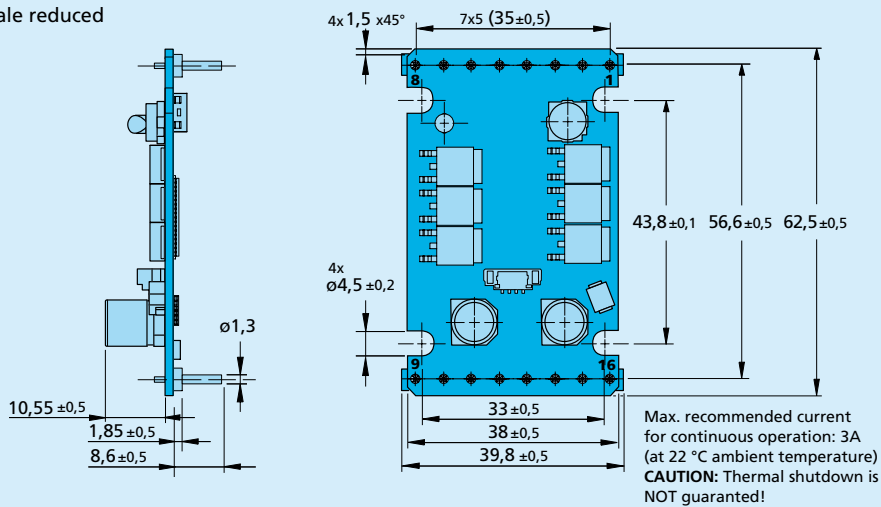

#### Connection

Pin	Function
1	Ph C
2	Hall A
3	+ 5V
4	SGND
5	Hall B
6	Hall C
7	Ph B
8	Ph A
9	CAN_H
10	CAN_L
11	AGND
12	Fault
13	AnIn
14	+ 24V
15	GND
16	3. In

### Dimensional drawing and connection information for MCLM 3006 C

Scale reduced

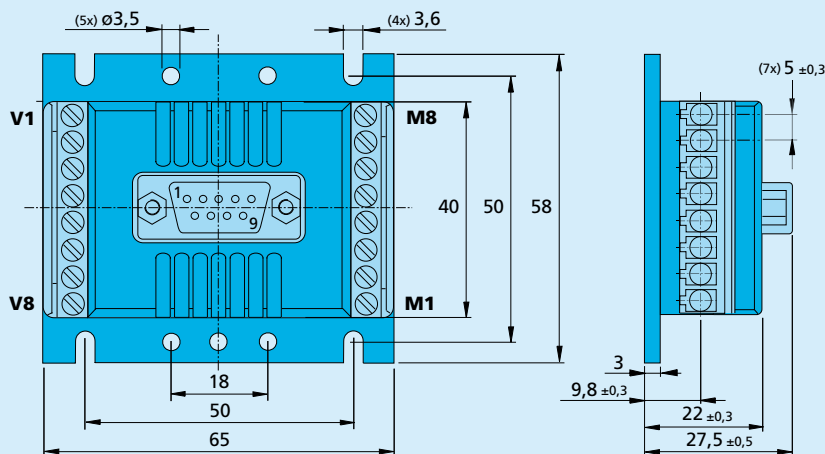

#### Motor connection

No.	Function
M1	Ph C
M2	Hall A
M3	+ 5V
M4	SGND
M5	Hall B
M6	Hall C
M7	Ph B
M8	Ph A

#### Supply connection

No.	Function
V1	CAN_H
V2	CAN_L
V3	AGND
V4	Fault
V5	AnIn
V6	+ 24V
V7	GND
V8	3. In