

Brushless DC-Servomotors

with integrated Speed Controller

4 Pole Technology

50 mNm

For combination with
Gearheads:
30/1, 32A, 32ALN, 32/3 (S), 38/1(S), 38/2(S)

Series 3242 ... BX4 SCDC

3242 G		012 BX4	024 BX4	SCDC
1 Nominal voltage	U_N	12	24	Volt
2 Terminal resistance, phase-phase	R	0,89	3,6	Ω
3 Output power ¹⁾	P_2 max.	21,2	21,1	W
4 Efficiency	η max.	77,4	77,3	%
5 No-load speed	n_0	5 300	5 400	rpm
6 No-load current	I_0	0,199	0,101	A
7 Stall torque	M_H	83	83	mNm
8 Friction torque, static	C_0	1,3	1,3	mNm
9 Friction torque, dynamic	C_v	$5,2 \cdot 10^{-4}$	$5,2 \cdot 10^{-4}$	mNm/rpm
10 Speed constant	k_n	455	227	rpm/V
11 Back-EMF constant	k_E	2,199	4,409	mV/rpm
12 Torque constant	k_M	21,0	42,1	mNm/A
13 Current constant	k_I	0,0476	0,0238	A/mNm
14 Slope of n-M curve	$\Delta n / \Delta M$	19,3	19,4	rpm/mNm
15 Terminal inductance, phase-phase	L	60	240	μH
16 Mechanical time constant	τ_m	6,1	6,1	ms
17 Rotor inertia	J	30	30	gcm ²
18 Angular acceleration	α max.	28	28	$\cdot 10^3$ rad/s ²
19 Thermal resistance	R_{th1} / R_{th2}	1,6 / 12,4		K/W
20 Thermal time constant	τ_{w1} / τ_{w2}	9 / 810		s
21 Operating temperature range		- 40 ... + 85		°C
22 Shaft bearings		ball bearings, preloaded		
23 Shaft load max.:				
– radial at 3 000 rpm (4,5 mm from mounting flange)		50		N
– axial at 3 000 rpm		5		N
– axial at standstill		50		N
24 Shaft play:				
– radial	\leq	0,015		mm
– axial	$=$	0		mm
25 Housing material		stainless steel		
26 Weight		189		g
27 Direction of rotation		electronically reversible		
28 Number of pole pairs		2		
Recommended values - mathematically independent of each other				
29 Speed up to	n_e max.	12 000	6 000	rpm
30 Torque up to ^{1) 2)}	M_e max.	27 / 29	28 / 50	mNm
31 Current up to ^{1) 2)}	I_e max.	1,60 / 1,60	0,82 / 1,40	A

¹⁾ at 5000 rpm

²⁾ thermal resistance R_{th2} not reduced / thermal resistance R_{th2} by 55% reduced

Note:

The diagram indicates the recommended speed in relation to the available torque at the output shaft for a given ambient temperature of 22°C.

The diagram shows the motor in a completely insulated as well as thermally coupled condition ($R_{th2} \geq 55\%$ reduced).

The motor is factory pre-configured to perform at the recommended continuous current. Non-standard configurations are only possible upon request from the manufacturer.

The nominal voltage (U_N) curve shows the operating point at nominal voltage in the insulated and thermally coupled condition. Any points of operation above the curve at nominal voltage will require a higher operating voltage. Any points below the nominal voltage curve will require less voltage.

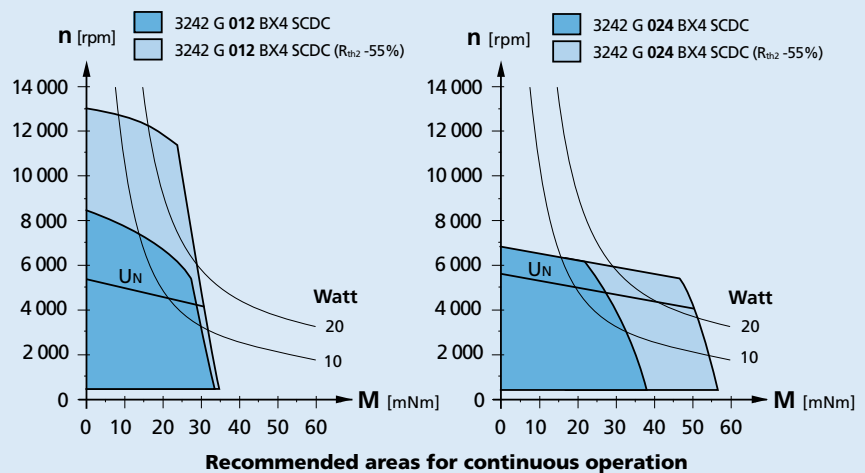

Dimensional drawing

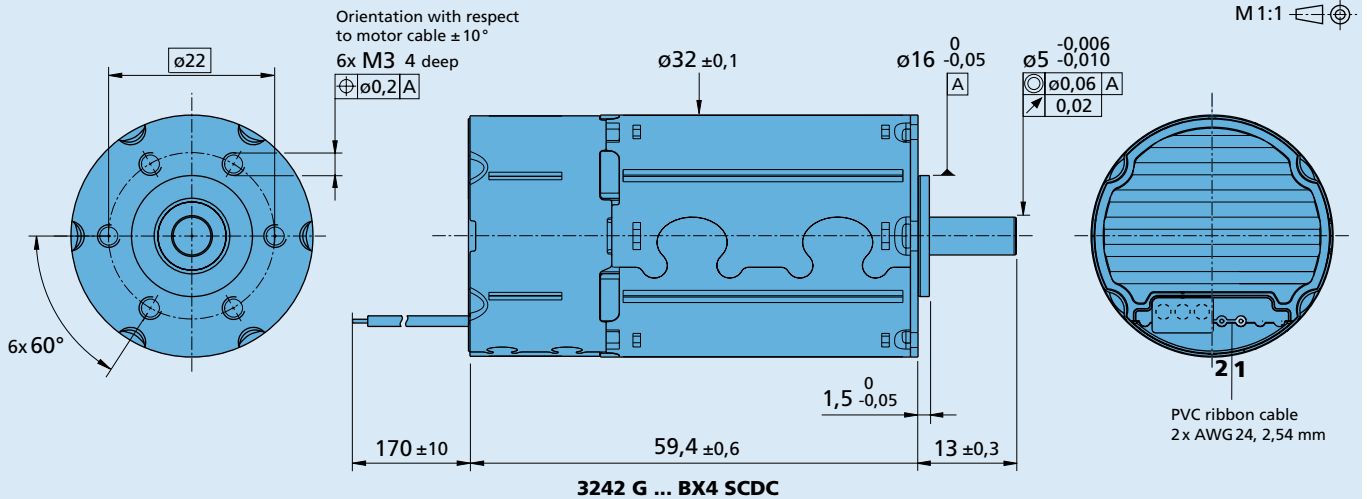

Speed Controller

		012 BX4	024 BX4	SCDC
Power supply electronic	U_p	6,5 ... 30		V DC
Power supply motor	U_{mot}	6,5 ... 30		V DC
PWM switching frequency	f_{PWM}	96		kHz
Efficiency	η	95		%
Max. continuous output current ¹⁾	I_{dauer}	1,6		A
Max. peak output current	I_{max}	4		A
Total standby current at U_N	I_{el}		17	10
				mA
Speed range, electronics		400 ... 50 000 ²⁾		rpm
Scanning rate		500		μs

¹⁾ at 22°C ambient temperature

²⁾ speed is dependent on the motor operating voltage

Connection information

Connection 1 "Mot +": positive power supply

Connection 2 "Mot -": negative power supply

Features

In this version, the brushless DC servomotors have an integrated Speed Controller. The motor is commutated using the integrated digital hall sensors. Speed control is via a PI regulator.

The Speed Controller has a current limiting device which limits the maximum motor current if the thermal load is too high. Twice the continuous current is possible over a short time.

The direction of rotation is dependent on the polarity of the voltage.

Full product description

■ Examples:

3242G012BX4 SCDC
3242G024BX4 SCDC

Connection information

Options

- Connector variants (Option no. 4140)
AWG 24 / PVC ribbon cable
with connector Micro-Fit
connector pin assignment:



Cable connection

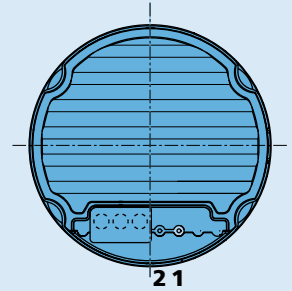

Connection

No.	Function
1	Mot +
2	Mot -