

Brushless DC-Servomotor

with integrated Motion Controller
and RS232 or CAN interface

50 mNm

For combination with
Gearheads:
30/1, 32/3, 32/3 S, 38/1, 38/1 S, 38/2, 38/2 S

3564 ... B CS/CC

	3564 K		024 B CS/CC	
Nominal voltage	U_N		24	Volt
Output power	$P_{2 \text{ max.}}$		90	W
Efficiency	$\eta_{\text{ max.}}$		80	%
No-load speed	n_o		10 500	rpm
No-load current	I_o		0,28	A
Peak torque for 8 A	M_P		160	mNm
Friction torque:				
– static	C_o		1,10	mNm
– dynamic	C_v		$2,4 \cdot 10^{-4}$	mNm/rpm
Torque constant	k_M		20,2	mNm/A
Current constant	k_i		0,05	A/mNm
Slope of n/M curve	$\Delta n / \Delta M$		31	rpm/mNm
Mechanical time constant	τ_m		11	ms
Rotor inertia	J		34	gcm^2
Angular acceleration	$\alpha_{\text{ max.}}$		109	$\cdot 10^3 \text{ rad/s}^2$
Thermal resistance	$R_{\text{th} 1} / R_{\text{th} 2}$	2,5 / 6,3		K/W
Thermal time constant	τ_{w1} / τ_{w2}	23 / 1 175		s
Operating temperature range		- 5 ... + 85		°C
Shaft bearings		ball bearings, preloaded		
Shaft load max.:				
– radial at 3000 rpm (7,4 mm from mounting flange)		108		N
– axial at 3000 rpm (push-on only)		50		N
– axial at standstill (push-on only)		131		N
Shaft play:				
– radial	$ \perp$	0,015		mm
– axial	$ $	0		mm
Housing material		aluminium, black anodized		
Weight		440		g
Direction of rotation		electronically reversible		

Recommended values - mathematically independent of each other

Speed range ¹⁾	n_e		5 - 12 000	rpm
Torque up to ²⁾	$M_{e \text{ max.}}$		50	mNm
Current up to ²⁾	$I_{e \text{ max.}}$		2,80 ³⁾	A

¹⁾ Power rating of 44 Watt at 8 400 rpm and 50 mNm

³⁾ This is a preset value and can be changed over the RS232 or CAN interface

²⁾ thermal resistance R_{th}

Dimensional drawing

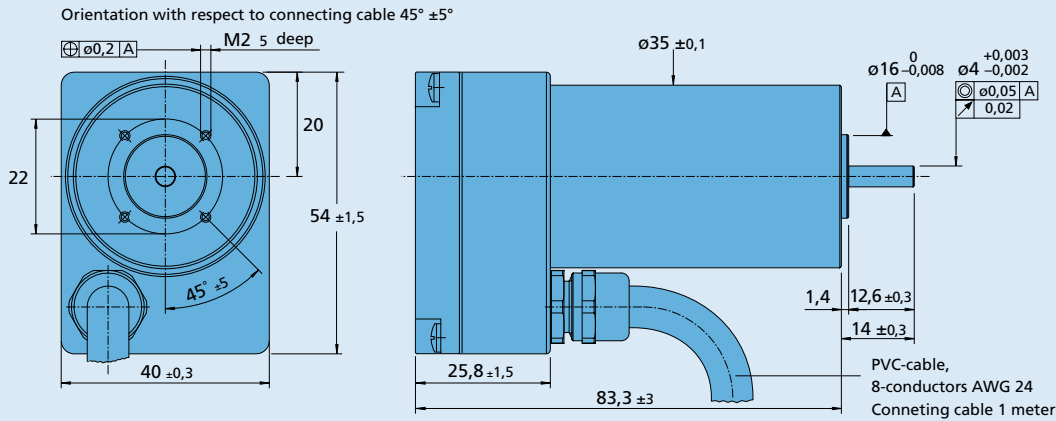

scale reduced 

Connection

Wires	Function
blue	GND
pink	+ 24 V
brown	Analog input
white	Fault output
grey	Analog GND
yellow	RS232 RXD / CAN_L
green	RS232 TXD / CAN_H
red	Connection No. 3

Caution:

be sure to connect motor supply terminals to the correct polarity. Motor electronics are protected against polarity reversal by an internal fuse. In case of damage due to polarity reversal, this internal fuse can only be replaced at the factory.

3564 ... B CS/CC

Options

Accessories

- Adapter board (Part No.: 6501.00065)

Full product description

- Example:
 - 3564K024B CS (RS232 interface)
 - 3564K024B CC (CAN interface)

Motion Controller

Supply voltage ¹⁾	U_B		12 ... 30	V DC
Peak current ²⁾	$I_{max.}$		8	A
Input/output			3	
Connection "Analog input":				
- Speed command analog input		voltage range	±10	V
- Speed command PWM input		frequency range	100 ... 2 000	Hz
		pulse duty factor 50%	0	rpm
- Digital input	$f_{max.}$	input resistance (at 24V)	5	kΩ
- External encoder	$f_{max.}$		400	kHz
- Step frequency input			400	kHz
Connection "Fault output":				
- Fault output		no error	switched to GND	
- Digital output		open collector	max. U_B / 30 mA	
- Digital input		input resistance	100	kΩ
Connection "3.input":				
- Digital input	U_B	input resistance	22	kΩ
- Electronic supply voltage ¹⁾			12 ... 30	V DC
Encoder:				
- Scanning rate			100	μs
- Resolution internal encoder			3 000	Inc./turn

The signal level of the digital inputs can be set using the above commands:
Standard (PLC): Low 0...7,0V / High 12,5V... U_B , TTL: Low 0...0,5V / High 3,5V... U_B

¹⁾ Separate supply of motor and control electronics for safetyrelevant applications is optionally available (Option no. 2993).

In this case the 3rd input is not available for digital signals; connection 3.

²⁾ Preset value. Can be changed over the interface.

MC Function / RS232

General description

FAULHABER Motion Controllers are available as external electronic controls to be used in combination with DC-Micromotors, Brushless DC-Servomotors and Linear DC-Servomotors or, if already integrated, with Brushless DC-Servomotors in the form of motion control systems. Motion control is thus possible for the majority of motors from a diameter of 6 mm upward. The integrated systems reduce the amount of space required. At the same time, their wiring requirements are minimal, which helps to simplify installation.

Operating modes

- **Speed control**
PI speed control, even for demanding synchronization requirements
- **Positioning**
For moving to defined positions with a high level of resolution. With a PD Controller, the dynamic response can be adjusted to suit the application. Reference and limit switches are evaluated by means of various homing modes.
- **Speed profiles**
Acceleration ramps, deceleration ramps and maximum velocity can also be defined for each section. As a result, even complex profiles can be implemented quickly and effectively.
- **Current control**
Protects the drive by limiting the motor current to the set peak current. The current is limited to the continuous current by the integrated I²t monitoring if required.
- **Protective functions**
 - Protection against ESD
 - Overload protection for the electronic circuitry and the motor
 - Self-protection against overheating
 - Overvoltage protection in generator mode
- **Extended operating modes**
 - Stepper motor mode
 - Gearing mode
 - Position control to analog set point
 - Operation as servo amplifier in voltage adjuster mode
 - Torque/force controller using variable set current input

Interfaces - Discrete I/O

- **Setpoint input**
Depending on the operating mode, setpoints can be input via the serial port, via an analog voltage value, a PWM signal or a quadrature signal.
- **Error output (Open Collector)**
This can also be used as a digital input for the evaluation of reference switches or for specifying direction of rotation.
- **RS232 interface**
For connection to a PC with a transmission rate of up to 115 kbaud. The information can be stored in the integrated memory (FLASH).

The interface also offers the option of querying online operating data and values. The RS232 interface also allows the operation of several networked drives on one control.

Sensor interfaces (position and speed sensors, depending on motor type)

- **Analog Hall signals**
Three analog Hall signals, offset by 120°, for motor position and speed in the case of Brushless DC-Motors and Linear DC-Servomotors
- **Incremental encoders**
Incremental encoders for motor position and speed in the case of DC-Micromotors and as additional sensors for Brushless DC-Motors
- **Absolute encoders**
Serial SSI port for motor position and speed matching Brushless DC-Servomotors with an AES Encoder

RS232 Programming / Configuration

An extensive ASCII command set is available for programming and operation. This can be preset from the PC, e.g. via any Windows terminal program or via any other control computer.

In addition, even complex processes can be created from these commands and stored in the drive. Once programmed as a stepper motor, electronic gear or as a speed or position controller via the analogue input, the drive can be operated independently of the RS232 interface.

"Faulhaber Motion Manager" software is available for Windows operating systems. It considerably simplifies operation and configuration and also enables graphic online analysis of the operating data.

Options

Separate supply of power to the motor and electronic actuator is optional (important for safety-relevant applications), in which case no third input is required. Depending on the controller, additional programming adaptors and connection aids are available. The modes and parameters can be specially preconfigured on request

Notes

Motion Controllers and Motion Control Systems are accompanied by a **device manual** for installation and putting into operation. A communication and function manual and the "**Faulhaber Motion Manager**" software are available on request and on the Internet at www.faulhaber.com.

Connection diagram

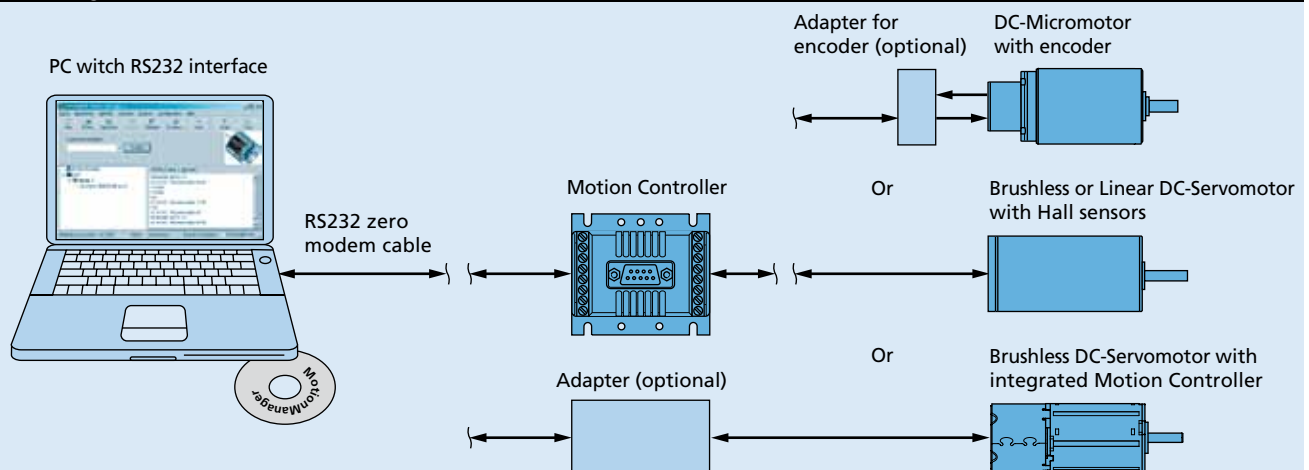

Position control DC-Micromotor with encoder

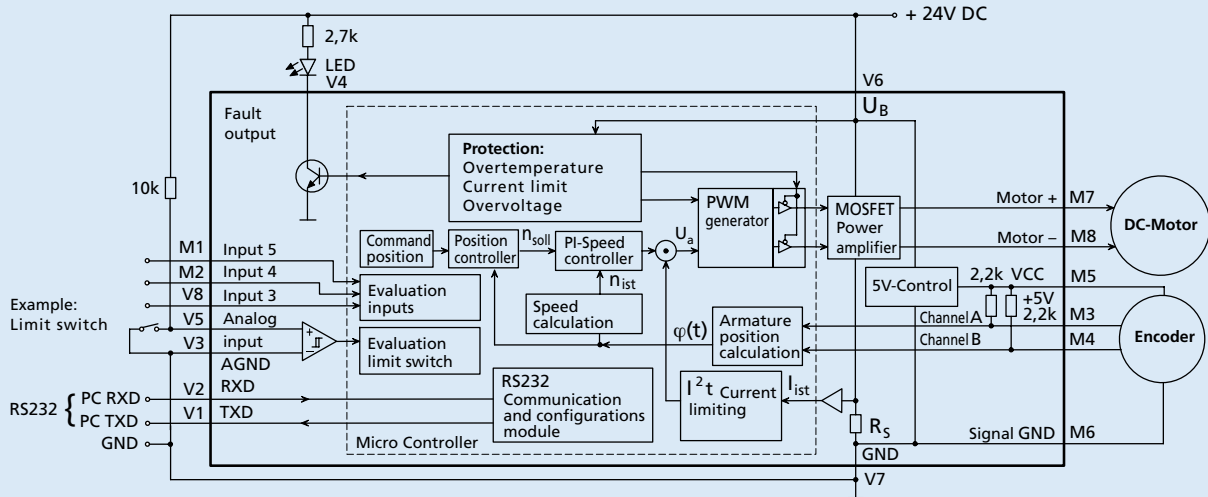

Position control Brushless DC-Servomotor with Hall sensors

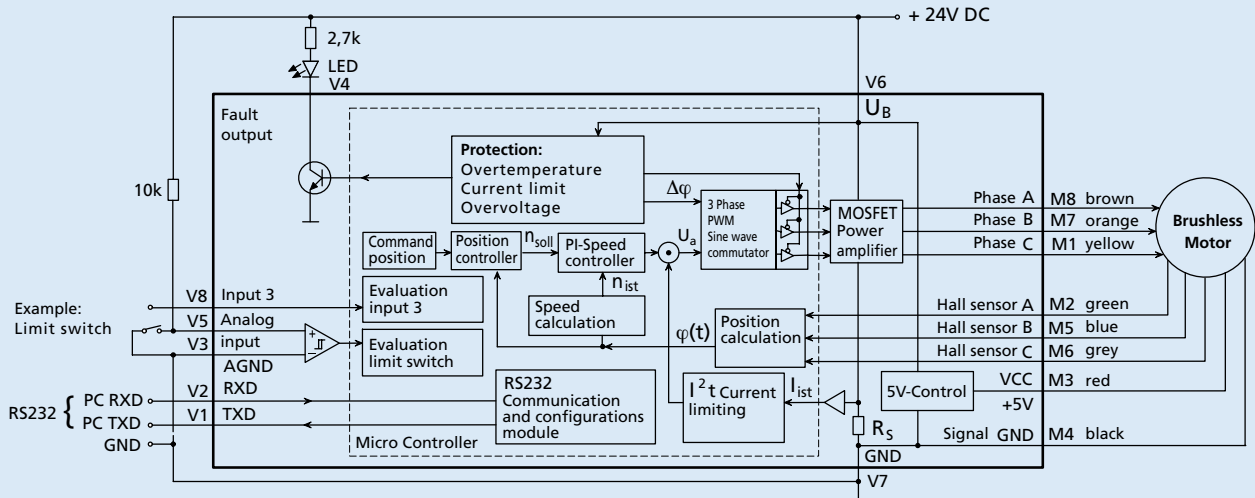

Position control Brushless DC-Servomotor with integrated Motion Controller

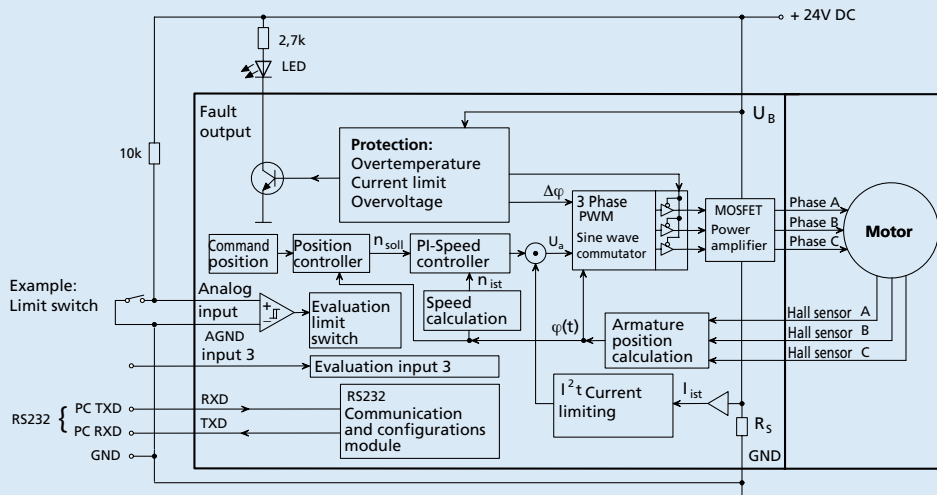

MC Function / CAN

General description

FAULHABER Motion Controllers are available as external electronic controls to be used in combination with DC-Micromotors, Brushless DC-Servomotors and Linear DC-Servomotors or, if already integrated, with Brushless DC-Servomotors in the form of motion control systems. Motion control is thus possible for the majority of motors from a diameter of 6 mm upward. The integrated systems reduce the amount of space required. At the same time, their wiring requirements are minimal, which helps to simplify installation.

Operating modes

- **Speed control**
PI speed control, even for demanding synchronization requirements
- **Positioning**
For moving to defined positions with a high level of resolution. With a PD Controller, the dynamic response can be adjusted to suit the application. Reference and limit switches are evaluated by means of various homing modes.
- **Speed profiles**
Acceleration ramps, deceleration ramps and maximum velocity can also be defined for each section. As a result, even complex profiles can be implemented quickly and effectively.
- **Current control**
Protects the drive by limiting the motor current to the set peak current. The current is limited to the continuous current by the integrated I²t monitoring if required.
- **Protective functions**
 - Protection against ESD
 - Overload protection for the electronic circuitry and the motor
 - Self-protection against overheating
 - Overvoltage protection in generator mode
- **Extended operating modes**
 - Stepper motor mode
 - Gearing mode
 - Position control to analog set point
 - Operation as servo amplifier in voltage adjuster mode
 - Torque/force controller using variable set current input

Interfaces - Discrete I/O

- **Setpoint input**
Depending on the operating mode, setpoints can be input via the serial port, via an analog voltage value, a PWM signal or a quadrature signal.
- **Error output (Open Collector)**
This can also be used as a digital input for the evaluation of reference switches or for specifying direction of rotation.
- **CANopen interface**
For integration into a CAN network with transfer rates of up to 1 Mbit/s. Via the CAN interface a number of drives can be networked and operated on a higher-level control.

Sensor interfaces (position and speed sensors, depending on motor type)

- **Analog Hall signals**
Three analog Hall signals, offset by 120°, for motor position and speed in the case of Brushless DC-Motors and Linear DC-Servomotors
- **Incremental encoders**
Incremental encoders for motor position and speed in the case of DC-Micromotors and as additional sensors for Brushless DC-Motors
- **Absolute encoders**
Serial SSI port for motor position and speed matching Brushless DC-Servomotors with an AES Encoder

CAN Programming / Configuration

FAULHABER Motion Controllers support the CANopen communication profile under DS301 V4.02 in accordance with the CiA specification for slave devices with the following services:

- 1 Server SDO
- 3 transmit PDOs, 3 receive PDOs
- Static PDO mapping
- NMT with node guarding
- Emergency Object

The transfer rate and node no. are set via the network in accordance with the LSS protocol conforming to DSP305 V1.11, and automatic baud rate detection is also implemented. In addition, all the functions and parameters of the drive unit can be easily activated via a special FAULHABER PDO channel.

As regards the CiA device profile for Motion Controllers (CiA 402), the following are supported:

- Profile Position Mode and Position Control Function
- Homing Mode
- Profile Velocity Mode

Also, for each Faulhaber command there is an appropriate CAN frame available on the PDO channel, with which the CAN unit can be operated in the same way as the serial variant and the extended operating modes can be supported.

"Faulhaber Motion Manager" software is available for Windows operating systems. It considerably simplifies operation and configuration and also enables graphic online analysis of the operating data.

Options

Separate supply of power to the motor and electronic actuator is optional (important for safety-relevant applications), in which case no third input is required. Depending on the controller, additional programming adaptors and connection aids are available. The modes and parameters can be specially preconfigured on request

Notes

Motion Controllers and Motion Control Systems are accompanied by a **device manual** for installation and putting into operation. A communication and function manual and the "**Faulhaber Motion Manager**" software are available on request and on the Internet at www.faulhaber.com.

Connection diagram

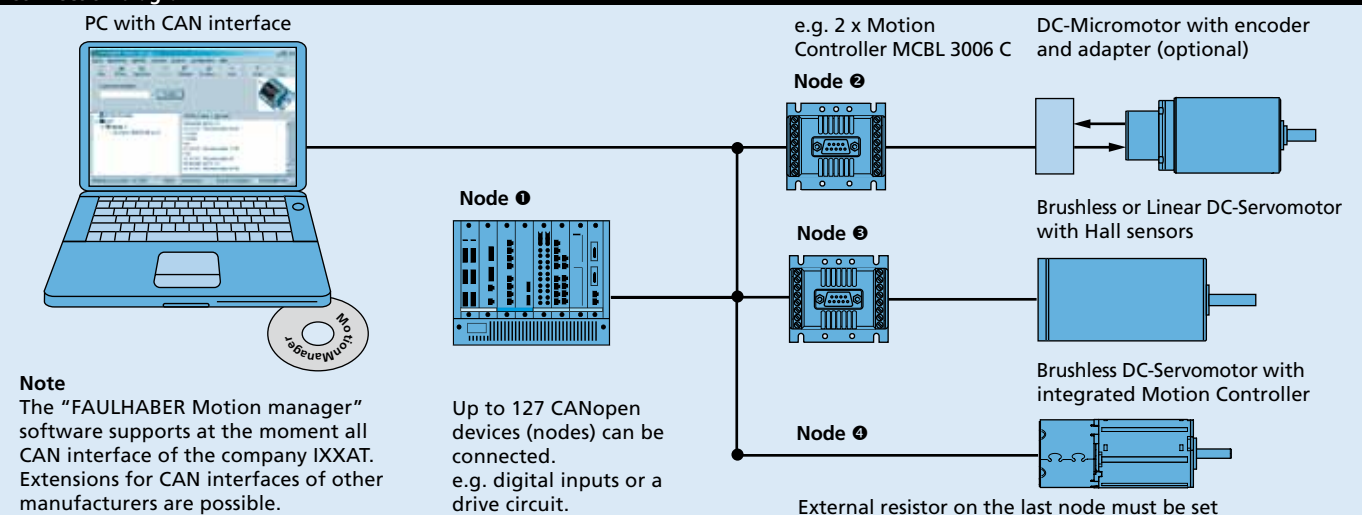

Note
The "FAULHABER Motion manager" software supports at the moment all CAN interface of the company IXXAT. Extensions for CAN interfaces of other manufacturers are possible.

Up to 127 CANopen devices (nodes) can be connected.
e.g. digital inputs or a drive circuit.

Position control DC-Micromotor with encoder

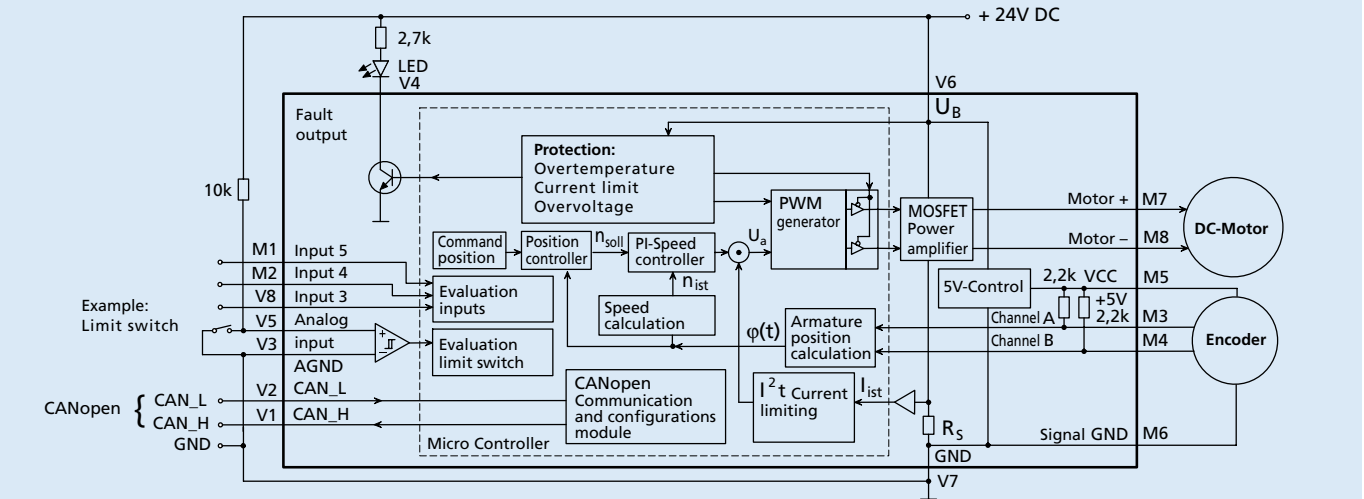

Position control Brushless DC-Servomotor with Hall sensors

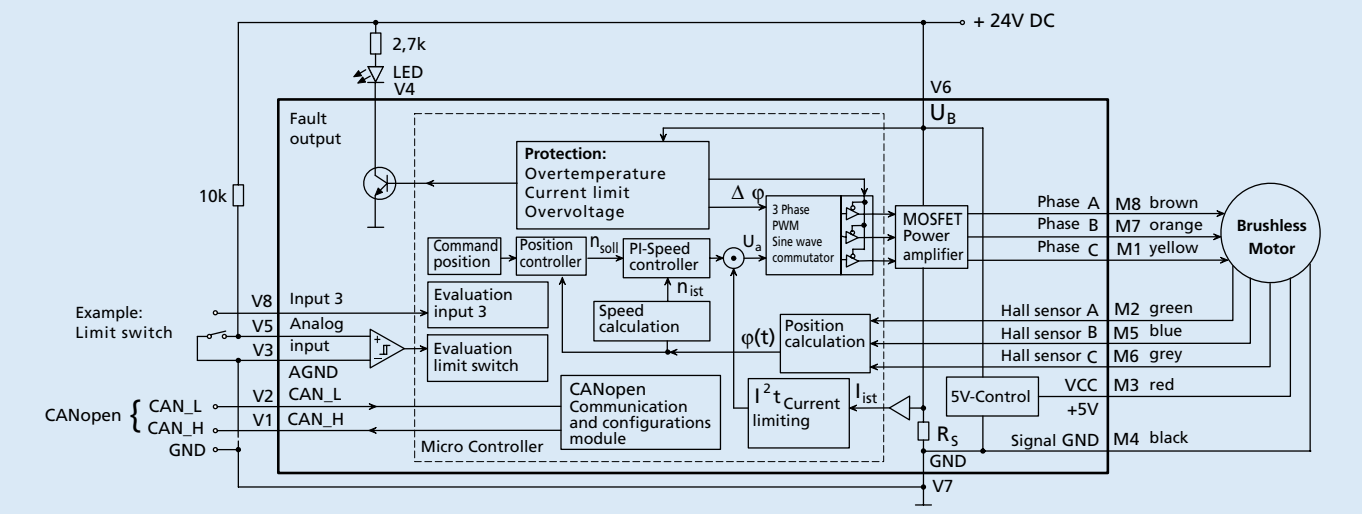

Position control Brushless DC-Servomotor with integrated Motion Controller

