

# Encoders

## Optical Encoders with Line Driver

- Features:**  
 1 000 Lines per revolution  
 3 Channels + complementary signals  
 Digital output  
 Line driver

### Series 40B

		40B		
Lines per revolution	N	1 000		
Signal output, square wave		2 + 1 index and complementary signals		channels
Supply voltage	V <sub>CC</sub>	4,5 ... 5,5		V DC
Current consumption, max. (V <sub>CC</sub> = 5 V DC)	I <sub>CC</sub>	100		mA
Pulse width	P	180 ± 18		°e
Index pulse width	P <sub>O</sub>	180 ± 36		°e
Phase shift, channel A to B	Φ	90 ± 18		°e
Signal rise/fall time, typical	tr/tf	0,25 / 0,25		µs
Frequency range <sup>1)</sup>	f	up to 200		kHz
Inertia of code disc	J	4,7		gcm <sup>2</sup>
Operating temperature range		- 40 ... + 120		°C
EMC radiated emission		EN 50081-2		
Protection classification		IP54		
<sup>1)</sup> Velocity (rpm) = f (Hz) x 60/N				

### Ordering information

Encoder type	number of channels	lines per revolution	For combination with brushless DC-Servomotors
40B27 - 1000/3	2+1	1 000	Series 4490

Suggested Line Receivers: AM26LS32, SN75175, MC3486

### Features

Designed for industrial environments, this high-performance incremental shaft encoder in combination with the Brushless DC-Servomotors is for the indication and control of both shaft velocity and direction of rotation as well as for positioning.

A LED source and lens system transmits collimated light through a low inertia disc to give two channels with 90° phase shift.

The index pulse is synchronized with the channel  $\bar{B}$ . Each encoder channel provides complementary output signals.

The single 5 volt supply and the digital output signals are interfaced with a shielded cable.

The line driver offers enhanced performance when the encoder is used in noisy environment, or when it is required to operate over long cables.

Details for the Brushless DC-Servomotors and suitable reduction gear-heads are on separate catalogue pages.

### Output signals / Circuit diagram

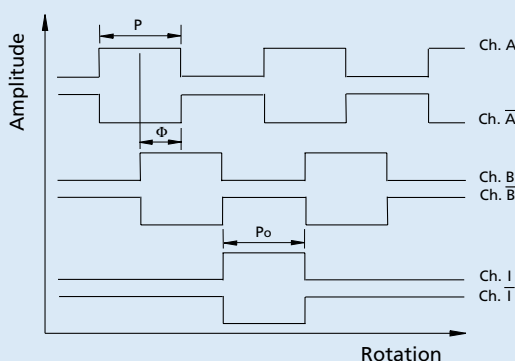

#### Output signals

with clockwise rotation as seen from the shaft end

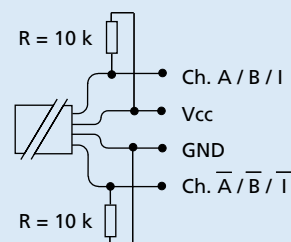

#### Connection diagram

Recommended pull-up and pull-down resistors for best signal quality

**Brushless DC-Servomotor 4490 H ... B - K1300, 4490 H ... BS - K1300 with Encoder 40B**

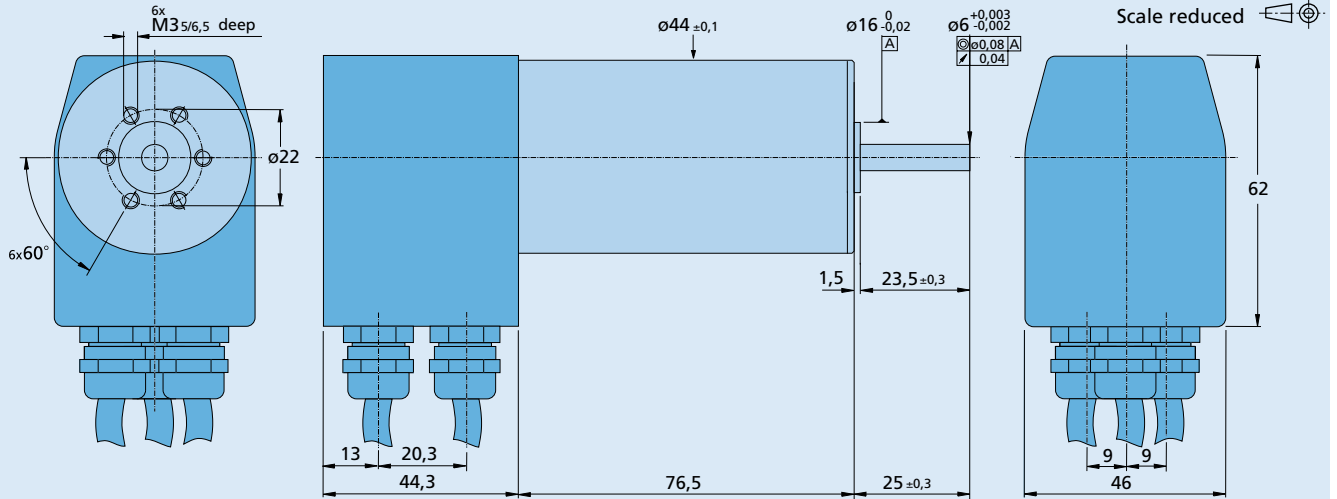

**Connection informations**

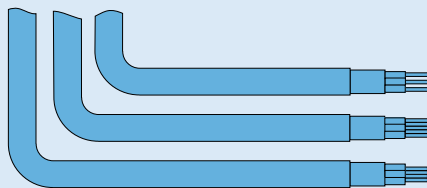

**Cables**

Shielded cables, PVC insulation, black  
Length 300 mm  $\pm$  15mm

**Motor power**  
3 conductors, AWG 16

**Encoder signals**  
8 conductors, AWG 28

**Motor logic**  
5 conductors, AWG 26

**Encoder signals**

Function	Colour
V <sub>CC</sub>	red
GND	black
A	green
$\bar{A}$	red / black
B	orange
$\bar{B}$	white / black
I	white
T	blue

**Motor power**

Function	Colour
Phase A	brown
Phase B	orange
Phase C	yellow

**Motor logic**

Function	Colour
Hall sensor A	green
Hall sensor B	blue
Hall sensor C	grey
Logical supply +5V	red
GND Logical	black