

Encoders

Magnetic Encoders

Features:
 1 to 16 Lines per revolution
 2 Channels
 Digital output

Series HEM

		Encoder Ø 10 ... 12 mm	Encoder Ø 16 ... 17 mm	
Lines per resolution	N	10 ... 12	1 ... 16	
Signal output, square wave		2	2	channels
Supply voltage	V	3,0 ... 15,0	3,0 ... 15,0	V DC
Current consumption, typical ($V_{cc} = 5$ V DC)	I_{cc}	5	5 ¹⁾	mA
Pulse width	P	180 ± 45	180 ± 45	°e
Phase shift, channel A to B	Φ	90 ± 45	90 ± 45	°e
Logic state width	S	90 ± 45	90 ± 45	°e
Cycle	C	360 ± 30	360 ± 30	°e
Signal rise/fall time, typical	tr/tf	5 / 0,2	5 / 0,2	µs
Frequency range up to	f	7,2	7,2	khz
Inertia of code disc	J	0,019	0,040	gcm ²
Operating temperature range		-20 ... +85	-20 ... +85	°C

¹⁾ current consumption for 1 ppr encoder = 11mA (typical at $V_{cc} = 5$ V DC) HEM-Q

Ordering information

Encoder type	number of channels	lines per revolution Ø 10 ... 12 mm	lines per revolution Ø 16 ... 17 mm	in combination with DC-Micromotors
HEM-10	2	10		series 0816...S series 1016...G, 1024...S series 1219...G, 1224...S
HEM-12	2	12		
HEM-Q ²⁾	2		1 ¹⁾	
HEM-10 ²⁾	2		10	series 1319...S, 1331...S, 1336...C series 1516...S, 1524...S series 1616...S, 1624...S series 1717...S, 1724...S, 1727...C series 2230...S, 2233...S series 3557...C, 3557...CR, 3557...CS
HEM-12 ²⁾	2		12	
HEM-15 ²⁾	2		15	
HEM-16 ²⁾	2		16	

²⁾ channel B leads channel A

Features

These incremental shaft encoders in combination with the FAULHABER® DC-Micromotors are designed for indication and control of both shaft velocity and direction of rotation as well as for positioning.

Solid state Hall sensors and a low inertia magnetic disc provide two channels with 90° phase shift.

The supply voltage for the encoder and the DC-Micromotor as well as the two channel output signals are interfaced with a ribbon cable to a 6-pin connector on motors ≤ 22mm in diameter for motors ≥ 23mm in diameter the motor voltage is supplied separately.

Details for the DC-Micromotors and suitable reduction gearheads are on separate catalog pages.

Please note: Velocity (rpm) = f (Hz) x 60/N

Output signals / Circuit diagram / Connector information

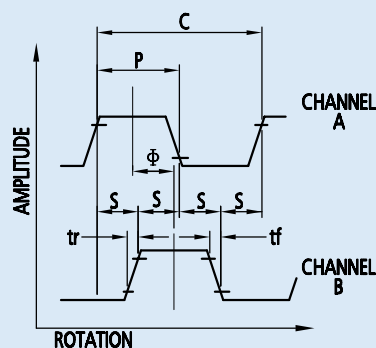

OUTPUT SIGNALS
 with clockwise rotation as seen from the shaft end
 exceptions indicated by note 3

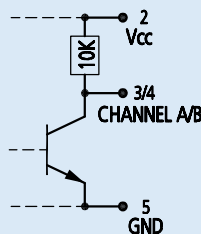

OUTPUT CIRCUIT
 * Motors 2342 and larger have separate motor connections

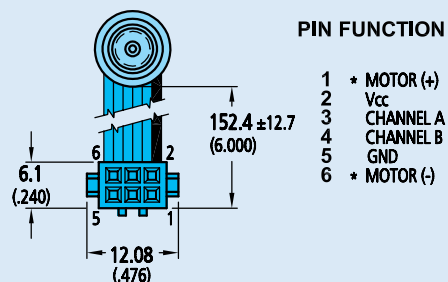

Shown with optional CONNECTOR (-6P)
 (Berg / FCI 71601-106)
 Polarized
 .050" Ribbon cable - PVC
 6 conductors - 28 AWG
 Mating connector:
 Header / FCI 75869-131

PIN FUNCTION

- 1 * MOTOR (+)
- 2 Vcc
- 3 CHANNEL A
- 4 CHANNEL B
- 5 GND
- 6 * MOTOR (-)

HEM

Encoder HEF Free standing

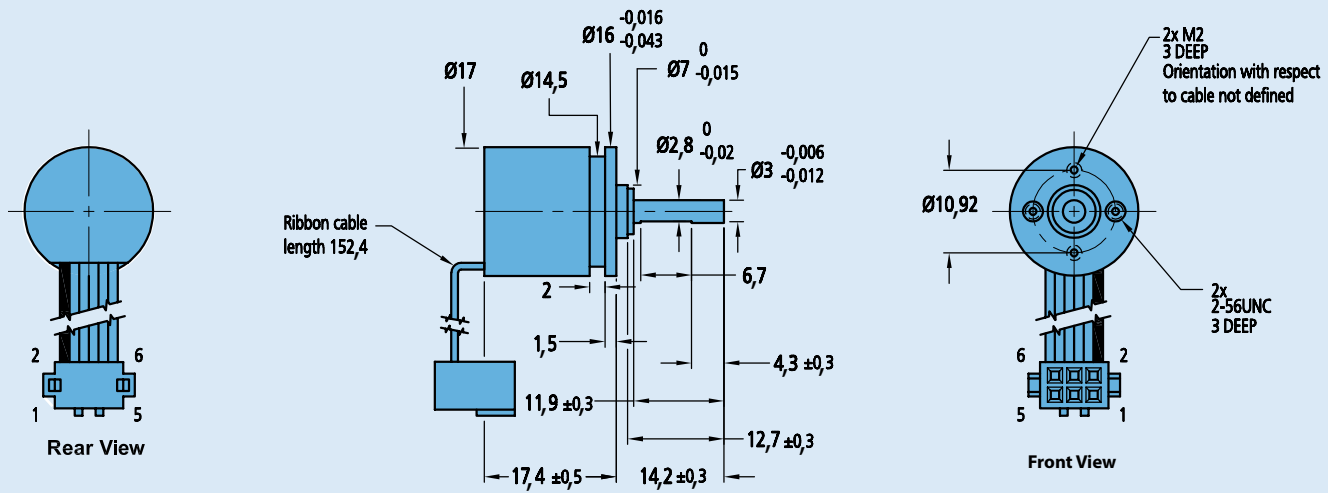

DC-Micromotor 0816 S, 1016 G, 12mm diameter series with HEM encoder

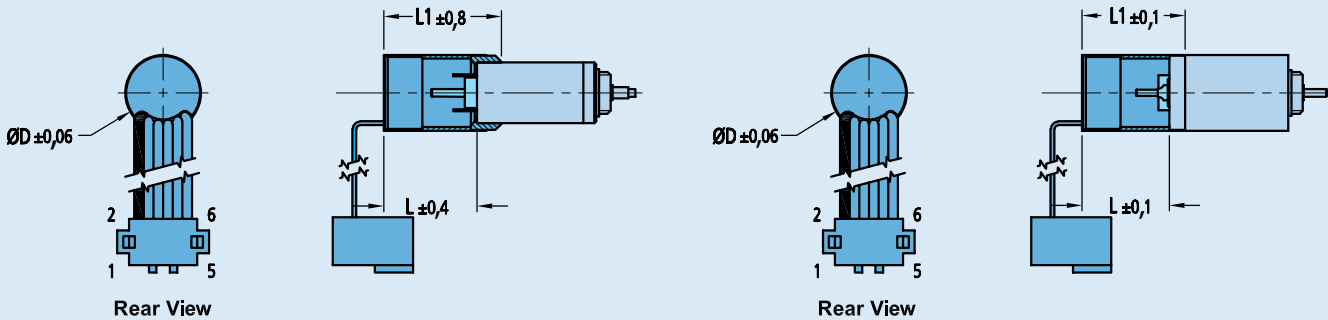

MODEL	ØD	L	L1
HEM 0816	10	12,3	15,5

HEM 0816

MODEL	ØD	L	L1
HEM 1016	10	11,5	13,5
HEM 12..	12	11,5	11,5

HEM 10../12..

DC-Micromotor 13mm diameter series with HEM encoder

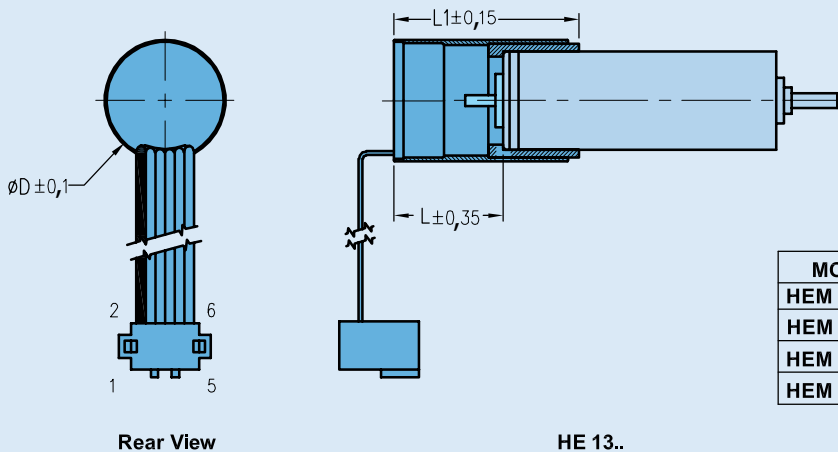

MODEL	ØD	L1	L
HEM 1319	16	20,5	14,4
HEM 1331E	16	32,69	14,5
HEM 1331T	16	23	14,4
HEM 1336	16	23	14,4

HE 13..

HEM

DC-Micromotor 15, 16, 17mm diameter series with HEM encoder

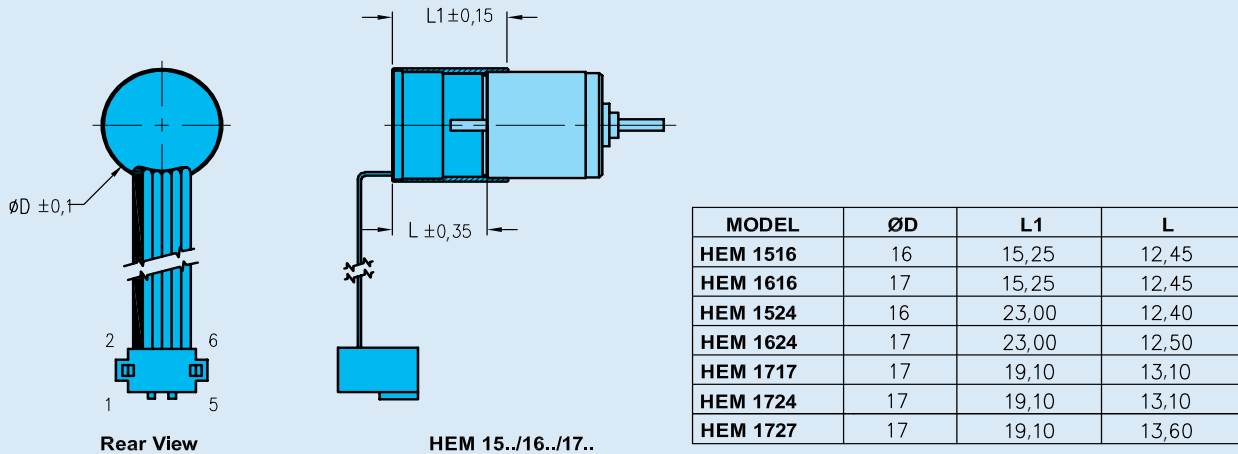

DC-Micromotor 22mm diameter series with Emcoder HEM

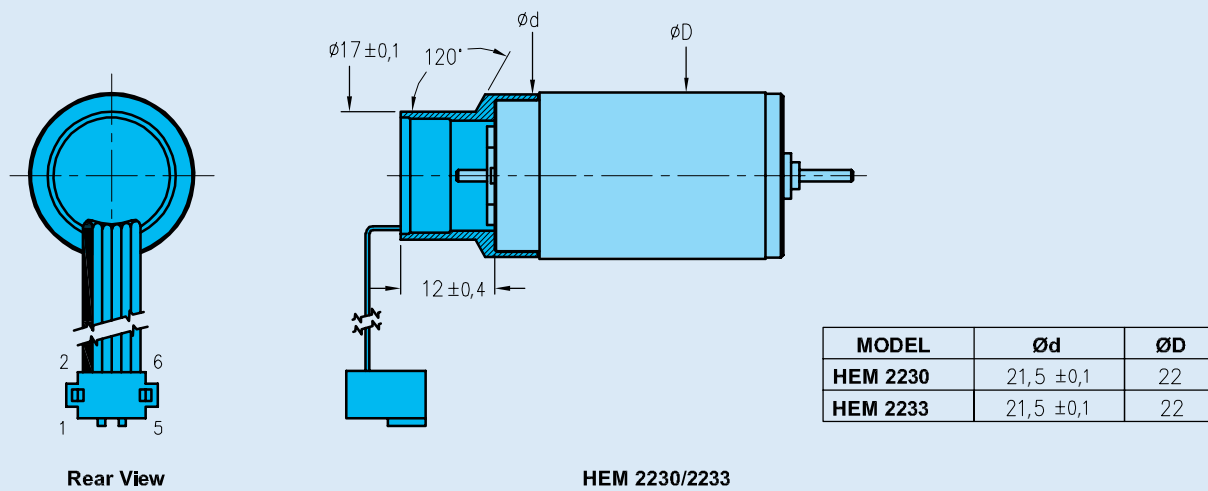

DC-Micromotor 3557 series with Emcoder HEM

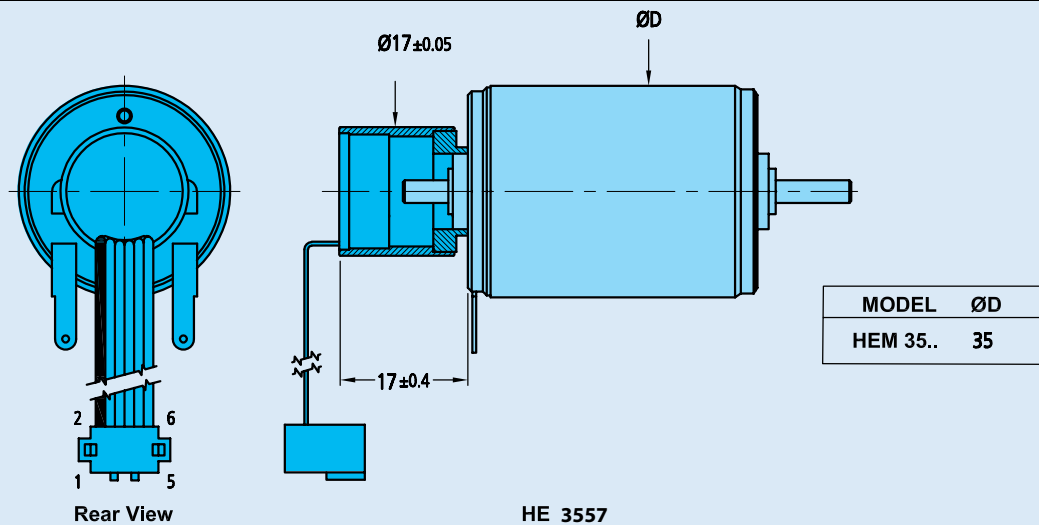

HEM ORDERING GUIDE

Encoder Magnetic
Ordering information

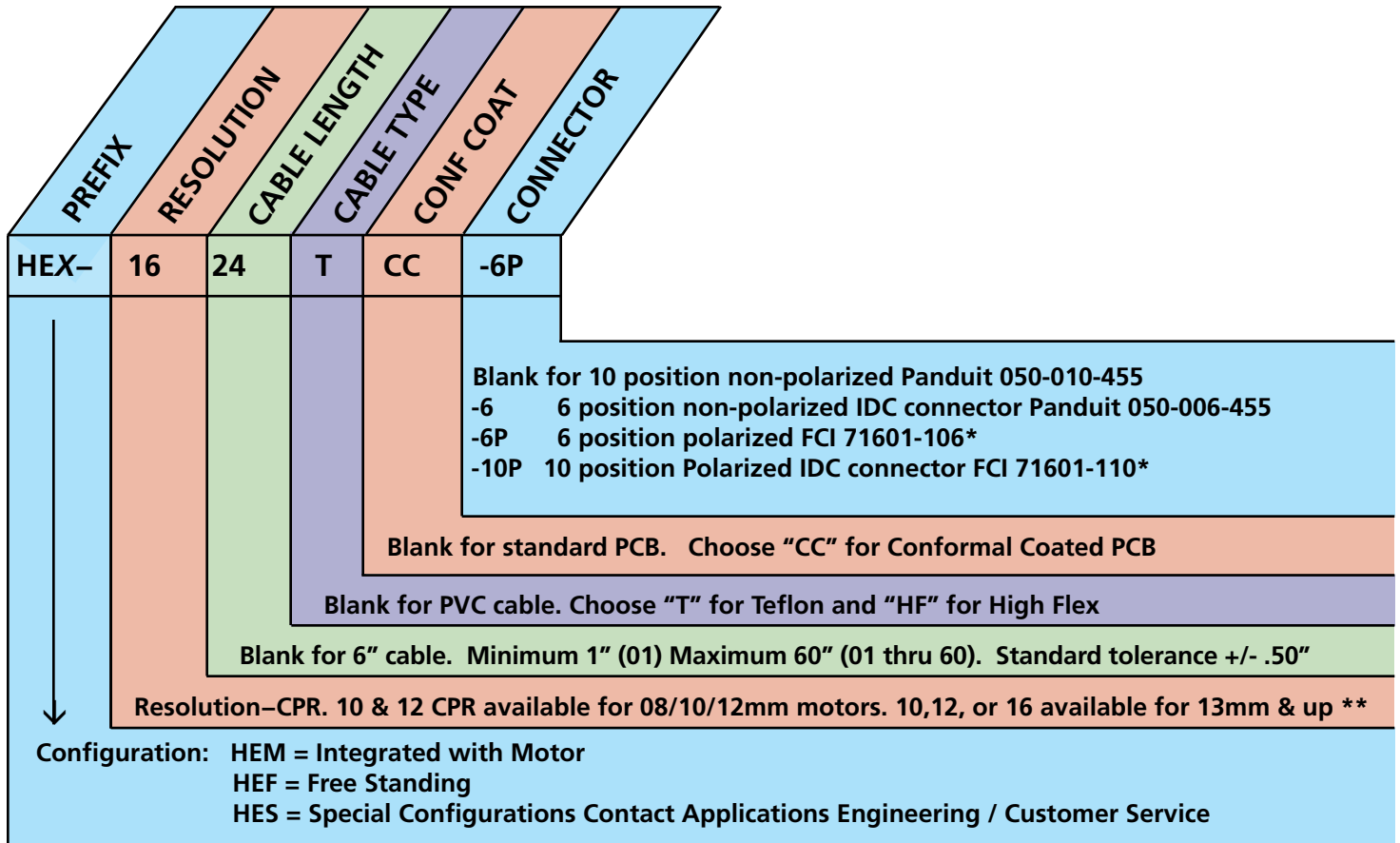

* Mating connectors available for Polarized Receptacles

** A "Q" in this position indicates 1 ppr quadrature technology