

# Encoders

## Optical Encoders

**Features:**  
 100 to 1024 Lines per revolution  
 2 or 3 Channels  
 Digital output

### Series 5500, 5540

		HEDS 5500	HEDS 5540	HEDM 5500	
Lines per revolution	N	100 - 500	100 - 500	1 000 - 1 024	
Signal output, square wave		2	2+1 index	2	channels
Supply voltage	V <sub>CC</sub>	4,5 ... 5,5			V DC
Current consumption, typical (V <sub>CC</sub> = 5 V DC)	I <sub>CC</sub>	17	57	57	mA
Pulse width	P	180 ± 45	180 ± 35	180 ± 45	°e
Phase shift, channel A to B	Φ	90 ± 20	90 ± 15	90 ± 15	°e
Logic state width	S	90 ± 45	90 ± 35	90 ± 45	°e
Cycle	C	360 ± 5,5	360 ± 5,5	360 ± 7,5	°e
Signal rise/fall time, typical	tr/tf	0,25 / 0,25			µs
Frequency range <sup>1)</sup>	f	up to 100	up to 100 <sup>2)</sup>	up to 100	kHz
Inertia of code disc	J	0,6			gcm <sup>2</sup>
Operating temperature range		- 40 ... + 100		- 40 ... + 70	°C

<sup>1)</sup> Velocity (rpm) = f (Hz) x 60/N

<sup>2)</sup> HEDS 5540 requires pull-up resistors of 2,7 kΩ between pins 2, 3, 5 and 4 (V<sub>CC</sub>)

#### Ordering information

Encoder type	number of channels	lines per revolution	For combination with:
HEDS 5500 C	2	100	DC-Micromotors and DC-Motor-Tachos Series 2230, 2233, 2251 2342 2642, 2657 3242, 3257, 3557, 3863  brushless DC-Servomotors Series 2036, 2057, 2444, 3056, 3564
HEDS 5500 A	2	500	
HEDS 5540 C	2+1	100	
HEDS 5540 A	2+1	500	
HEDM 5500 B	2	1 000	
HEDM 5500 J	2	1 024	

**Interlocking connector options:** extension cables 300 mm length, on request.

#### Features

These incremental shaft encoders in combination with the DC-Micromotors and brushless DC-Servomotors are designed for the indication and control of both shaft velocity and direction of rotation as well as for positioning.

A LED source and lens system transmits collimated light through a low inertia metal disc to give two channels with 90° phase shift.

The single 5 volt supply and the two or three channel digital output signals are interfaced with a 5-pin connector.

Motors with ball bearings are recommended for continuous operation at low and high speeds and for elevated radial shaft load.

Details for the Motors and suitable reduction gearheads are on separate catalogue pages.

#### Output signals / Circuit diagram / Connector information

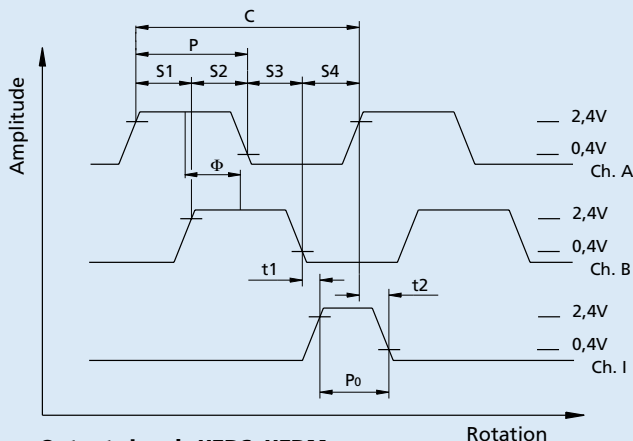

**Output signals HEDS, HEDM**  
 with clockwise rotation as seen from the shaft end

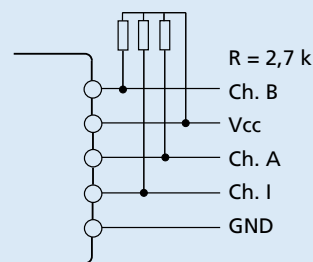

**Connection diagram**  
 HEDS 5540 requires pull-up resistors

#### Pin Function

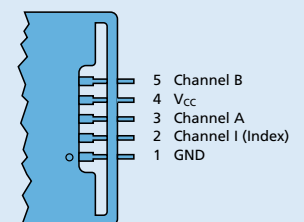

#### Connector

suggested connectors  
 AMP 103686-4/640442-5,  
 Molex 2695/2759  
 FCI 65039-032 / 4825x-000

scale reduced

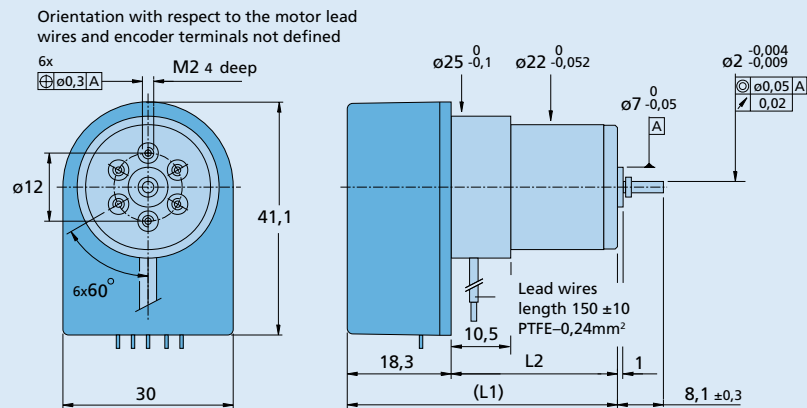

**Encoders HEDS 5500, 5540**  
with DC-Micromotors 2230, 2233

Motor type	L1	L2
2230	52,8	34,5
2233	55,6	37,3

scale reduced

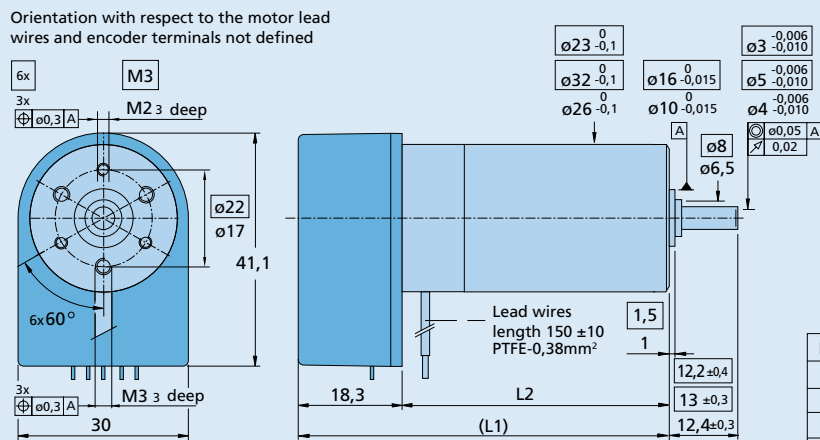

**Encoders HEDS 5500, 5540**  
with DC-Micromotors 2342, 2642, 2657, 3242, 3257

Motor type	L1	L2
2342	63,8	45,5
2642	64,8	46,5
2657	79,8	61,5
3242	65,3	47,0
3257	80,3	62,0

scale reduced

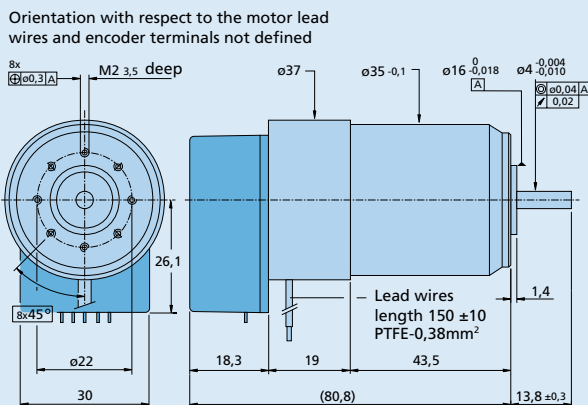

**Encoders HEDS 5500, 5540**  
with DC-Micromotor 3557

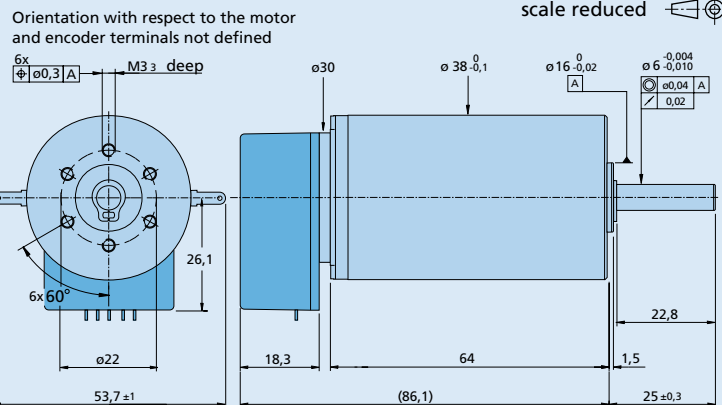

**Encoders HEDS 5500, 5540**  
with DC-Micromotor 3863

scale reduced 

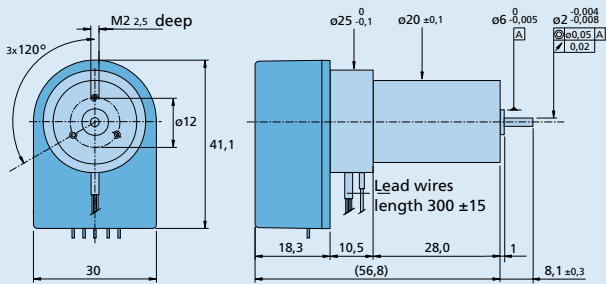

**Encoders HEDS 5500, 5540**  
with Brushless DC-Servomotor 2036 U ... B - K312

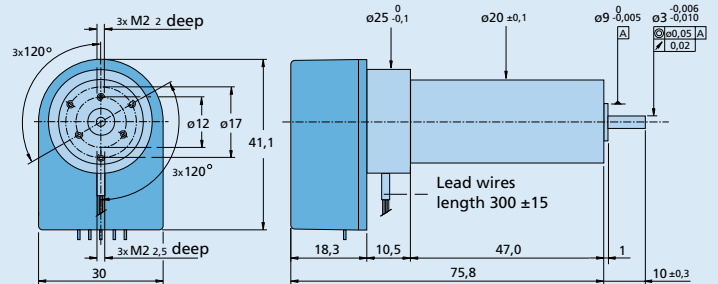

**Encoders HEDS 5500, 5540**  
with Brushless DC-Servomotor 2057 S ... B - K312

scale reduced 

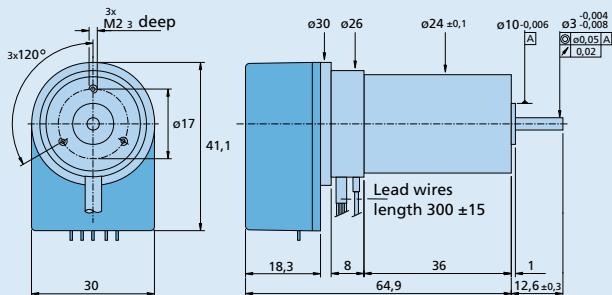

**Encoders HEDS 5500, 5540**  
with Brushless DC-Servomotor 2444 S ... B - K312

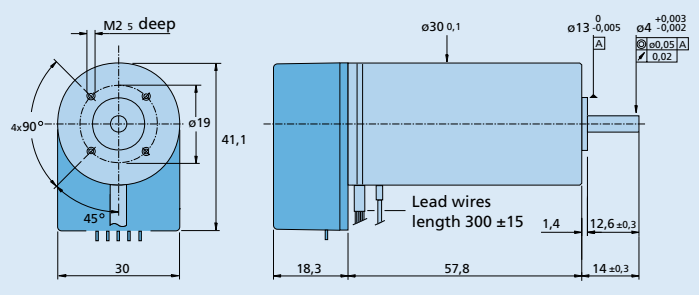

**Encoders HEDS 5500, 5540**  
with Brushless DC-Servomotor 3056 K ... B - K312

scale reduced 

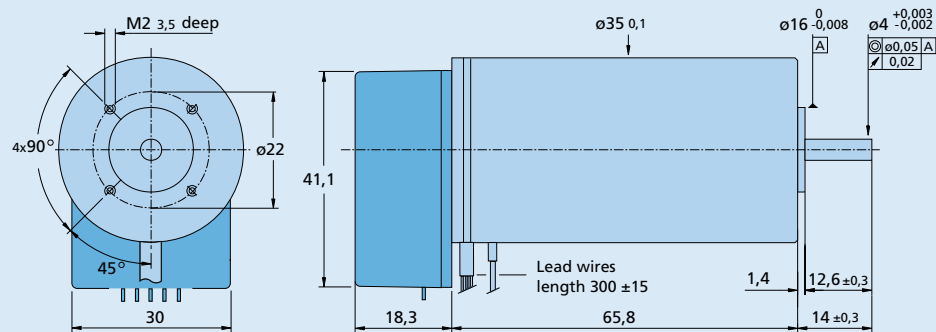

**Encoders HEDS 5500, 5540**  
with Brushless DC-Servomotor 3564 K ... B - K312