

Encoders

Magnetic Encoders

For combination with:
Stepper Motor: AM1524

Series AE 23B8

		AE 23B8	
Lines per revolution	N	12	
Signal output, square wave		2	channels
Supply voltage	V _{CC}	5 ... 15	V DC
Current consumption, typical (V _{CC} = 5 V DC)	I _{CC}	5	mA
Pulse width	P	180 ±45	°e
Phase shift, channel A to B	Φ	90 ±45	°e
Logic state width	S	90 ±45	°e
Cycle	C	360 ±30	°e
Signal rise/fall time, typical	tr / tf	5 / 0,2	µs
Frequency range ¹⁾	f	up to 7,2	kHz
Inertia of code disc	J	20	·10 ⁻⁹ kgm ²
Operating temperature range		-20 ... +85	°C

¹⁾ Velocity (rpm) = f (Hz) x 60/N

Features / Output signals / Circuit diagram

These incremental shaft encoders are designed for indication and control of shaft velocity and direction of rotation as well as for position verification.

Solid state Hall sensors and a low inertia magnetic disc provide two channels with 90° phase shift.

The supply voltages for the encoder and the stepper motor as well as the two channel output signals are interfaced through a cable and 10-pin connector.

Details for the stepper motors and suitable reduction gearheads are on the corresponding data sheets.

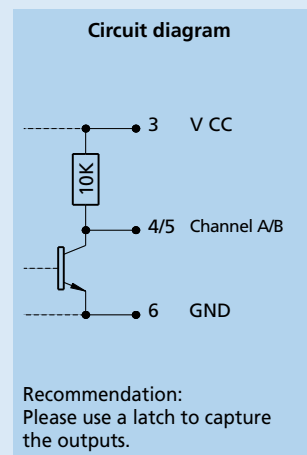
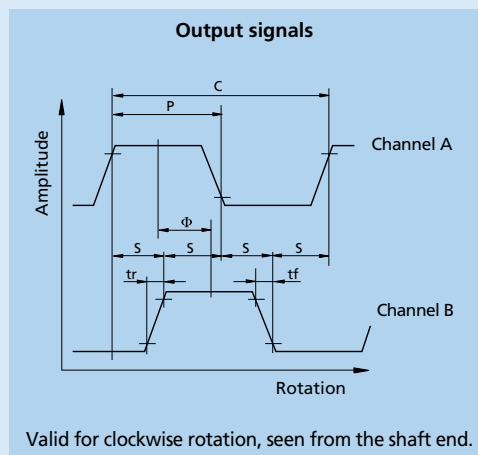

Cable connection

Pin	Function
1	Motor Phase B -
2	Motor Phase B +
3	V _{CC}
4	Channel A
5	Channel B
6	GND
7	Motor Phase A -
8	Motor Phase A +

Connector type Panduit 050-010-455
Ribbon cable, 120 mm - PVC
8 conductors - 0,09 mm²

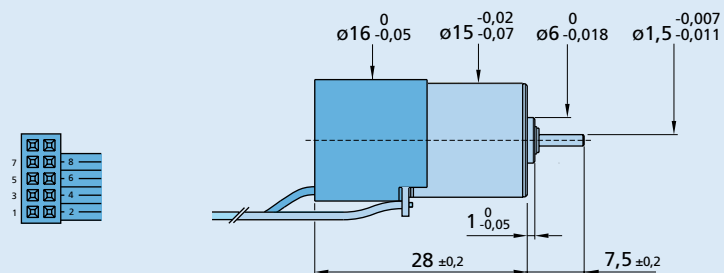

AE 23B8