

Block diagram of the Servo Amplifier BLD 7010 for speed control with Hall sensor feedback

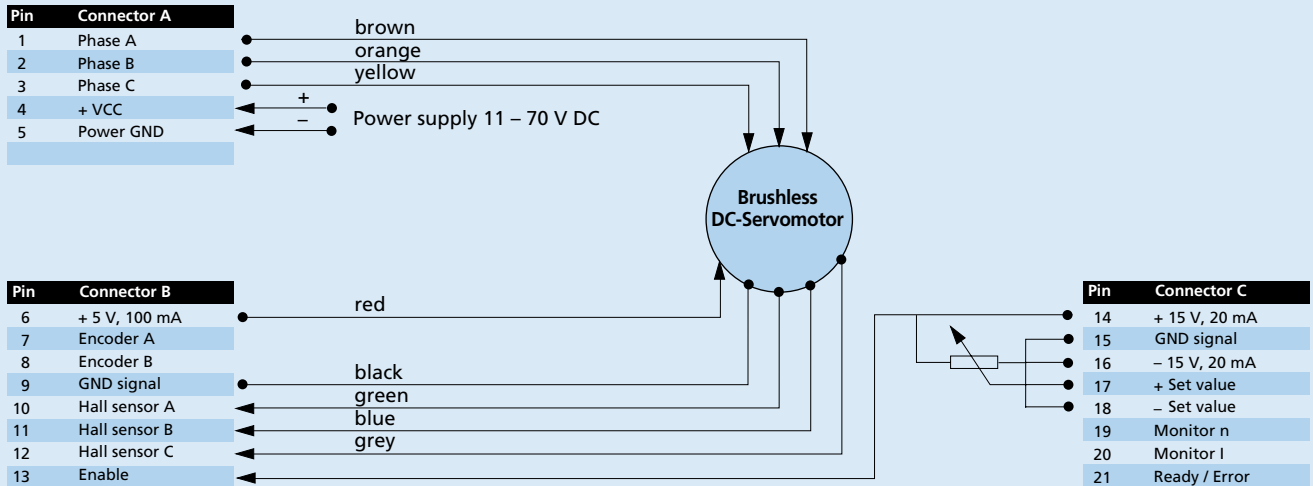

Block diagram of the Servo Amplifier BLD 7010 for speed control with Encoder feedback

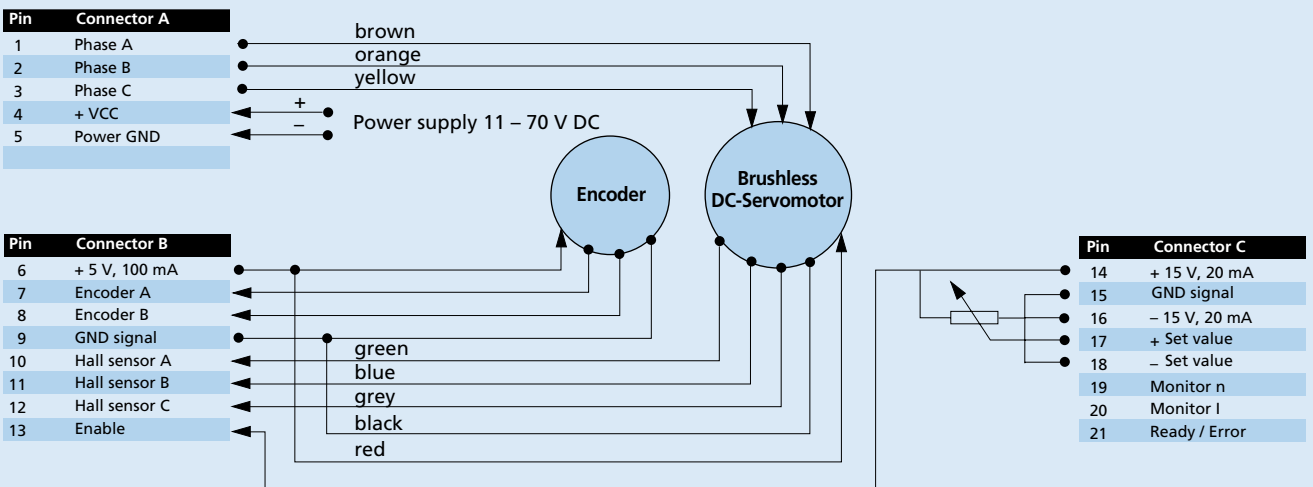

Dimensional drawing

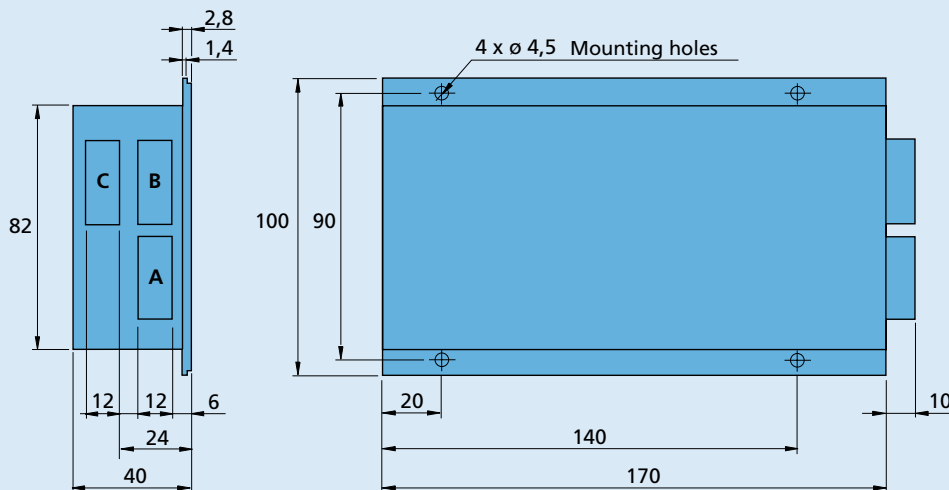

Connection	
Pin	Function
A	Motor and power supply
B	Hall signals and encoder
C	Logical