



Motion Control Systems
Series 3564K024B CS
Motion Controller
Series MCBL 3003/06 S
Series MCDC 3003/06 S

Instruction Manual

EN

RS232

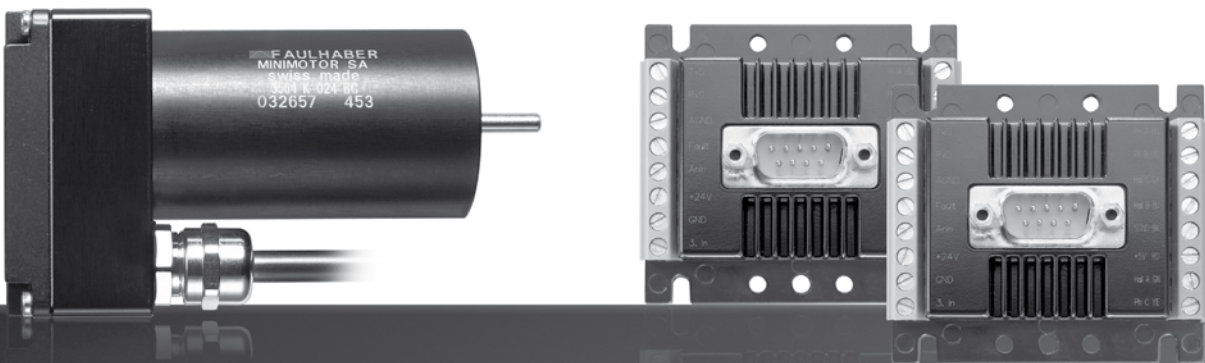

Imprint

Version:
4th edition, 29.09.2009

Copyright
by Dr. Fritz Faulhaber GmbH & Co. KG
Daimlerstr. 23/25 · 71101 Schönaich

All rights reserved, including translation rights.
No part of this description may be duplicated, reproduced, stored in an information system or processed or transferred in any other form without prior express written permission of Dr. Fritz Faulhaber GmbH & Co. KG.

This instruction manual has been prepared with care.
Dr. Fritz Faulhaber GmbH & Co. KG cannot accept any liability for any errors in this instruction manual or for the consequences of such errors. Equally, no liability can be accepted for direct or consequential damages resulting from improper use of the equipment.

The pertinent regulations regarding safety engineering and interference suppression as well as the specifications in this instruction manual must be complied with when using the equipment.

Subject to modifications.

The current version of this instruction manual is available on FAULHABER's internet site:
www.faulhaber.com

Table of Contents

1	Important Information	6
1.1	Symbols used in this instruction manual	6
1.2	Safety instructions	7
2	Description	8
2.1	General product description, motor 3564K024B CS	8
2.2	General product description, Motion Controller	9
2.3	Quick start	11
2.3.1	Operation via FAULHABER Motion Manager	11
2.3.2	Operation via own host application	13
3	Installation	14
3.1	Assembly	14
3.2	EMC compatible installation	15
3.2.1	Description of the EMC measures	15
3.3	Connector pin assignment	16
3.3.1	3564K024B CS	16
3.3.2	MCBL 3003/06 S	16
3.3.3	MCDC 3003/06 S	17
3.4	RS232 wiring	19
3.5	Motor wiring	20
3.6	Baud rate and node number	21
3.7	Basic settings	24
3.8	Compatibility mode	25
4	Functional description	26
4.1	Position control	27
4.2	Velocity control	29
4.2.1	Velocity presetting via RS232	29
4.2.2	Analog velocity presetting	30
4.3	Homing and limit switches	32
4.4	Enhanced operating modes	35
4.4.1	Stepper motor mode	35
4.4.2	Gearing mode (electronic gear)	36
4.4.3	Analog positioning mode	37
4.4.4	External encoder as actual value (not MCDC)	38
4.4.5	Voltage regulator mode	39
4.4.6	Analog target current presetting	39
4.4.7	IxR control for DC controllers	39
4.5	Special functions of the error connection	40
4.6	Sequence programs	42
4.7	Trace function	51
4.8	Technical information	53
4.8.1	Sinus commutation	53
4.8.2	Current regulator and I ² t current limitation	53
4.8.3	Overtemperature protection	54
4.8.4	Under-voltage monitoring	54
4.8.5	Overvoltage regulation	55
4.8.6	Adjustment of the controller parameters	55

Table of Contents

5	Parameter description	57
5.1	Basic setting commands	58
5.1.1	Commands for special operating modes	58
5.1.2	Parameters for basic setting	58
5.1.3	General parameters	59
5.1.4	Configuration of fault pin and digital inputs	60
5.1.5	Configuration of homing and limit switches in	60
5.2	Query commands for basic setting	61
5.2.1	Operating modes and general parameters	61
5.2.2	Configuration of fault pin and digital inputs	65
5.2.3	Configuration of homing	65
5.3	Miscellaneous commands	66
5.4	Motion control commands	67
5.5	General query commands	68
5.6	Commands for sequence programs	69
5.7	Configuration at delivery	71
6	Operation	73
6.1	Commissioning	73
7	Maintenance	74
7.1	Service/Maintenance	74
7.2	Troubleshooting	74
8	Technical Data	75
8.1	Motor 3564K024B CS	75
8.1.1	Operating data	75
8.1.2	Product dimensions	76
8.1.3	Connection information	76
8.2	Motion Controller MCBL 3003/06 S	77
8.2.1	Operating data	77
8.2.2	Product dimensions	77
8.2.3	Connection information	78
8.3	Motion Controller MCDC 3003/06 S	80
8.3.1	Operating data	80
8.3.2	Product dimensions	80
8.2.3	Connection information	81
9	EMC	83
9.1	EC Directives	83
9.2	Electromagnetic compatibility (EMC)	84
9.3	EC Declaration of Conformity	86
10	Manufacturer's Declaration	87
11	Warranty	88
12	Command overview	89

1 Important Information

This instruction manual describes the handling and technical features of the following FAULHABER equipment:

3564K024B CS

The 3564K024B CS integrates a brushless DC-Servomotor with a high-resolution encoder to determine actual position and a motion controller in one complete drive unit.

MCBL 3003/06 S

The MCBL 3003/06 S is an external motion controller for brushless DC servomotors with linear Hall sensors, which can be operated without additional encoders.

MCDC 3003/06 S

The MCDC 3003/06 S is an external motion controller that is designed for the entire range of FAULHABER DC micro motors.

- Please read the complete instruction manual before using the controller.
- Keep this instruction manual in a safe place for later use.

The information given in this instruction manual refers to the standard versions of the respective equipment. Please refer to any additional information sheet provided in the event of differences in information due to a customer-specific modification.

1.1 Symbols used in this instruction manual

WARNING!



Warning!

This pictogram with the wording "Warning!" indicates an imminent danger which can result in physical injuries.

- ▶ *This arrow points out the appropriate action to take to prevent the imminent danger.*

CAUTION!



Caution!

This pictogram with the wording "Caution!" indicates an imminent danger which can result in slight physical injuries or material damage.

- ▶ *This arrow points out the appropriate precautions.*

REGULATION



Regulations, guidelines and directives

This pictogram with the wording "Regulation" indicates a statutory regulation, guideline or directive which must be observed in the respective context of the text.

NOTE



Note

This "Note" pictogram provides tips and recommendations for use and handling of the component.

1 Important Information

1.2 Safety instructions

Observance of the following safety instructions is prerequisite for trouble-free and safe operation of the motor and the Motion Controller. Therefore, please carefully read through all the notes and follow them when using the controllers.

Intended use

FAULHABER Motion Controllers are designed for the control of DC and BL motors. They have numerous functions and operating modes which enable flexible adjustment to the respective drive function. Thanks to the compact design, the units can be integrated into diverse applications with minimal wiring. The flexible connection options open up a broad field of application in all areas, for example in decentralized automation technology systems, as well as in handling devices and machine tools. The Motion Controller's control parameters can be individually adjusted to the respective application via a PC. The "FAULHABER Motion Manager" PC software for Microsoft Windows is available for commissioning and configuration of the Motion Controller and can be downloaded free of charge from the FAULHABER Homepage www.faulhaber.com.

- Subject to compliance with the conditions described in Chapter 9 "EMC", the Motion Controllers fulfil the relevant EMC Directives. Any effects as well as the specific relevant national regulations must be taken into account when using the motor.
- The Motion Controllers contain electronic components and are to be treated according to the ESD regulations.
- The Motion Controllers may not be used in environments where contact with water, chemicals and/or dust is possible or in potentially explosive atmospheres.
- Please ask the manufacturer for information about individual use under special ambient conditions.

2 Description

2.1 General product description, motor 3564K024B CS

The 3564K024B CS combines an electronically commutated DC-Servomotor, a high-resolution encoder to determine actual position and a programmable position and speed controller, based on a high capacity digital signal processor (DSP), within a complete drive unit.

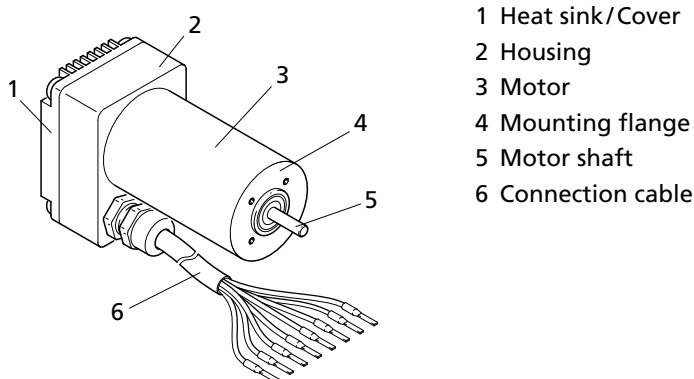

- 1 Heat sink/Cover
- 2 Housing
- 3 Motor
- 4 Mounting flange
- 5 Motor shaft
- 6 Connection cable

The motor is designed for the following drive functions:

- **Velocity control** from 5 to 12 000 rpm with superior performance specifications in respect of synchronous operation and minimal torque fluctuations. A PI controller ensures maintaining of the target velocities.
- **Velocity profiles** such as ramp, triangular or trapezoidal movements can be realised. Gentle starting or deceleration can easily be implemented.
- **Positioning mode:** A PID controller is implemented for high positioning precision. with a resolution of 1/3000 revolutions.
- Acquisition of **reference marks and end position switches**.
- Enhanced operating modes: **Stepper motor mode, analog positioning mode, voltage controller, electronic gear, operation with external incremental encoder.**
- **Torque control** via adjustable current limitation.
- **Storage** of the set configurations.
- **Storage and execution** of sequence programs.

Various inputs and outputs are available for implementation of these functions:

- **Set value input** for target velocity. Analog or PWM signal can be used. The input can also be used as digital or reference input. A frequency signal or an external incremental encoder can also be connected here.
- **Error output** (Open Collector). Can also be reprogrammed as rotational direction, digital or reference mark input, and as pulse or digital output.
- 1 additional **digital input**.
- **RS232 interface** for connection to PC or control with transfer rates of up to 115 kBaud. An extensive ASCII command set is available for programming and operation.

NOTE



RS232 interface

The drive can also be operated independently of the RS232 interface if the desired function, such as velocity or position controller via analog input, stepper motor or electronic gear has been programmed previously.

2 Description

2.1 General product description, motor 3564K024B CS

Options

Separate power supply for the motor and control electronics is possible as an ex-factory option (important for safety-relevant applications). In this case the 3rd input pin is not available for digital input. Special preconfiguration of modes and parameters is possible on request.

The Motion Manager software can be downloaded free of charge from www.faulhaber.com.

2.2 General product description, Motion Controller

All of the Motion Controllers are based on a high performance digital signal processor (DSP), which enables a high control quality, precise positioning and very low speeds.

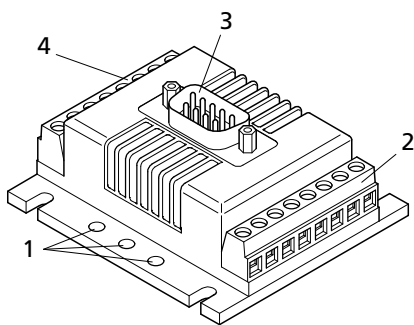

- 1 Mounting threads
- 2 Screw-type terminal strip, motor end
- 3 D-Sub connector for serial connection
- 4 Screw-type terminal strip, supply end

The Motion Controllers are designed for the following functions:

- **Velocity control** with high requirements on synchronous operation and minimal torque fluctuations. A PI controller ensures maintaining the target velocities.
- **Velocity profiles** such as ramp, triangular or trapezoidal movements can be realised. Gentle starting or deceleration can easily be implemented.
- **Positioning mode:** A PID controller is implemented for high positioning precision.
- Acquisition of **reference marks and end position switches**.
- Enhanced operating modes: **Stepper motor mode, analog positioning mode, voltage controller, electronic gear, operation with external incremental encoder. MCDC 3003/06 S: IxR control.**
- **Torque control** via adjustable current limitation.
- **Storage** of the set configurations.
- **Storage and execution** of sequence programs.

2 Description

2.2 General product description, Motion Controller

Various inputs and outputs are available for implementation of these functions:

- **Set value input** for target velocity. Analog or PWM signal can be used. The input can also be used as digital or reference input. A frequency signal or an external incremental encoder can also be connected here.
- **Error output** (Open Collector). Can also be reprogrammed as rotational direction, digital or reference mark input, and as pulse or digital output.
- 1 to 3 additional **digital inputs**.
- **RS232 interface** for connection to PC or control with transfer rates of up to 115 kBaud. An extensive ASCII command set is available for programming and operation.

NOTE



RS232 interface

The drive can also be operated independently of the RS232 interface if the desired function, such as velocity or position controller via analog input, stepper motor or electronic gear has been programmed previously.

Options

Separate power supply for the motor and control electronics is possible as an ex-factory option (important for safety-relevant applications). In this case the 3rd input pin is not available for digital input. Special preconfiguration of modes and parameters is possible on request.

The Motion Manager software can be downloaded free of charge from www.faulhaber.com.

2 Description

2.3 Quick start

To facilitate introduction, this chapter highlights the initial steps for commissioning and operation of FAULHABER Motion Controllers with serial interface. However, the detailed documentation must always be read and adhered to, particularly chapter 3.7 "Basic settings"!

The units are delivered as standard without a valid node address (NODEADR0) and with a transfer rate of 9600 baud. The settings can be changed via the interface, e.g. with the FAULHABER Motion Manager.

If the FAULHABER Motion Manager is to be used to change the connection parameters, proceed as follows:

1. Connect drive unit to a serial interface of the PC (e.g. COM1) via null modem cable and switch on.
2. Start FAULHABER Motion Manager.
3. Activate serial interface as communication interface and configure via the menu item "Terminal – Connections...".
4. Select menu item "Configuration – Connection parameters...".
5. Set desired transfer rate and node address.
6. Press "Send" button.
7. The settings are transferred to the controller. The Motion Manager then adjusts to the same baud rate and recalls the Scan function. The node should now be displayed with the correct node number in Node Explorer.
8. If the settings are to be permanently stored, the "EEPSAV" button must then be pressed. After switching off and on again, the drive will operate with the set configuration.

2.3.1 Operation via FAULHABER Motion Manager

The FAULHABER Motion Manager offers easy access to the Motion Controller's command set. The desired node must have been activated beforehand by double clicking in Node Explorer in the case of network operation.

The FAULHABER commands described below can be entered directly in the command input line or selected from the Commands menu.

In order to drive a motor via the Motion Manager, follow the procedure below (assuming a matching baud rate):

1. Configure drive functions:

A user-friendly dialog that enables the desired settings to be made is available under the menu item "Configuration – Drive functions...".

2 Description

2.3 Quick start

CAUTION!



Check basic settings

Incorrect values in the Motion Controller's settings can result in damage to the controller and/or drive.

► *For external Motion Controllers MCBL 3003/06 S and MDCD 3003/06 S, you must check that the correct basic settings have been made for the connected motor (see chapter 3.7 "Basic settings").*

For brushless motors, the correct motor type must be set, for DC motors the correct pulse number must be specified for the encoder (ENCRES) under "Drive parameters".

For operating the drive via the PC, the set value presetting must be set to digital (SOR0).

If the settings are to be permanently stored, press the "EEPSAV" button.

2. Activate drive:

"EN" command.

Enter in command input field and press "Send" button or select in "Commands – Motion control – Enable drive" menu and press "Send" button.

3. Operate motor (examples):

- Drive motor with 100 rpm velocity control:

"v100" command.

Enter in command input field and press "Send" button or select in "Commands – Motion control – Initiate velocity mode" menu, enter value 100 in dialogue box, press OK and "Send" button.

- Stop motor:

"v0" command:

- Move motor relatively by 10000 increments:

"IR10000" command to load the relative target position, "M" command to move to loaded target position.

2 Description

2.3 Quick start

2.3.2 Operation via own host application

Set your host application to the controller transfer rate (default 9600 baud) with the following configuration:

- 8 data bits
- 1 stop bit
- No Parity

The Xon/Xoff protocol must be used for rapid command sequences or transfer of sequence programs and parameter sets.

An extensive set of ASCII commands is available for operating the FAULHABER Motion Controllers. The ASCII commands have the following structure:

[Node No.]	Command	[Argument]	CR
------------	---------	------------	----

The node number is optional and is only required if several drives are being operated on one interface. The command consists of a letter character string. The optional argument consists of an ASCII numeric value. The end is always a CR character (Carriage Return, ASCII decimal code 13). Space characters are ignored, and no distinction is made between upper and lower case.

The response to query commands or asynchronous events is also an ASCII character string, followed by a CR character (Carriage Return, ASCII decimal code 13) and an LF character (Line Feed, ASCII decimal code 10).

Example:

- Actual position queries:
 - Transmit: **P**OS [CR]
 - Receive: **98956** [CR] [LF]
- Drive motor at 500 rpm:
 - Transmit: **V**500 [CR]

If ANSW2 is set, you will receive an "OK" when the command has been successfully executed. If an execution error occurred you will receive one of the following character strings:

- "Unknown command"
- "Invalid parameter"
- "Command not available"
- "Overtemperature – drive disabled"

Example:

Transmit: **V**500 [CR]
 Receive: **OK** [CR] [LF]

The EEPsAV command always responds with the character string "EEPROM writing done" after successful saving of the current settings in the data Flash memory, or with "Flash defect", if the save has failed.

All commands are listed in Chapter 5 "Parameter Description".

3 Installation

3.1 Assembly

The place of installation must be selected so that clean and dry cooling air is available for cooling the unit. The units are intended for indoor operation. Large amounts of dust and high concentrations of chemical pollutants must be avoided.

Cooling of the unit must be guaranteed, especially when installing in housings and cabinets. As the unit operates with surface cooling, temperatures of up to 85 °C can occur. Operation is only guaranteed if the supply voltage lies within the defined tolerance ranges.

Wiring work may only be carried out on terminal strips and connections if the units are voltage-free. Please also note the additional instructions on installation in Chapter 9 "EMC".

CAUTION!



Risk of damage

Incorrect assembly or assembly with the wrong fixing materials can cause damage to the Motion Controller.

- ▶ *Observe the following assembly instructions.*

Specialised staff

Only trained specialised staff and instructed persons with knowledge in the field of automation technology and standards and regulations such as **EMC Directive, Low Voltage Directive, Machinery Directive, VDE Regulations (such as DIN VDE 0100, DIN VDE 0113/ EN 0204, DIN VDE 0160/EN 50178), Accident Prevention Regulations** may install and commission the units. This description must be carefully read and heeded prior to commissioning.

Off load

The Motion Controller must be disconnected from the power supply for all types of assembly and connection work.

Surface

Motion Controllers may be screwed onto flat, hard surfaces only.

Screw-type terminal strips

The maximum tightening torque of the screw-type terminal strips must be noted and observed. See Chapter 8 "Technical Data".

3 Installation

3.2 EMC compatible installation

CAUTION!



Length of the connection leads

The maximum length of the connection leads is limited.

- ▶ None of the connection leads, with the exception of the power supply, may exceed a length of 3 m.

Optimisation of performance with respect to emission and immunity requires the additional EMC measures:

- Ensuring allowable emissions or necessary immunity in the industrial sector may require the use of an EMC filter and / or an EMC suppressor circuit.

Motion Controller	Use environment	Interference type	Action
MCDC 3006 S	Industrial sector	Emission	EMC filter
MCBL 3006 S	Industrial sector	Emission	EMC filter
MCBL 3006 S	Industrial sector	Immunity	EMC suppressor circuit

This table shows which additional EMC measures can be implemented to optimise the behaviour of the equipment in the intended environment with regard to emission and immunity.

The devices are intended for use in the industrial sector only. If the devices are used in the home, in business or in commerce or in a small business, appropriate measures must be taken to ensure that the emitted interference is below the permitted limits!

3.2.1 Description of the EMC measures

The EMC filter (for MCDC 3006S and MCBL 3006S only)

The electronics and motor supply cables must be laid directly on the unit, each with two windings through a suitable ferrite sleeve (e.g. Würth Elektronik No.: 74270090).

The EMC suppressor circuit (for MCBL 3006S only)

The signal cables of the MCBL 3006S must be laid directly on the unit with two windings through a star ring (e.g. Würth Elektronik No.: 7427153).

3 Installation

3.3 Connector pin assignment

Depending on their type, Motion Controllers are equipped with either screw-type terminal strips or pin headers as connection options. The 3564K024B CS motor is equipped with an eight-core connection cable (AWG 24).

CAUTION!



Electronic damage/ESD protection

Electrostatic discharges at the Motion Controller's connections can cause destruction of the electronics.

► Note and follow the ESD protective measures.

Incorrect connection of the cores can cause damage to or destruction of the electronics.

► Connect the connections in accordance with the connector pin assignment, see table.

Please also note the additional instructions on installation in Chapter 9 "EMC".

CAUTION!



Power supply connections (+24 V, GND)

*Malfunctions can occur if an inadequately dimensioned power supply is used. If the supply leads are incorrectly connected (polarity reversal) the internal fuse trips. **This must be replaced in the factory!***

► The power supply should be adequately dimensioned for the connected motor.

► Be sure to connect motor supply terminals to the correct polarity.

3.3.1 3564K024B CS

The connections are executed as coloured stranded wires and assigned as follows:

Wires	Designation	Meaning
blue	GND	GND
pink	+24 V	+24 V
brown	AnIn	Analog input
white	Fault	Error output
grey	AGND	Analog GND
yellow	RxD	RS232 RxD
green	TxD	RS232 TxD
red	3.In	3rd input optional electronic supply U _B

3.3.2 MCBL 3003/06 S

The connections are indicated on the terminal strips and are assigned as follows:

Connector pin assignment, supply side

Connection	Designation	Meaning
1	TxD	RS232 TxD
2	RxD	RS232 RxD
3	AGND	Analog GND
4	Fault	Error output
5	AnIn	Analog input
6	+24 V	+24 V
7	GND	GND
8	3. In	3rd input optional electronic supply U _B

3 Installation

3.3 Connector pin assignment

Connector pin assignment, motor side

Connection	Designation	Wire colour	Meaning
1	Ph A	brown	Motor phase A
2	Ph B	orange	Motor phase B
3	Hall C	grey	Hall sensor C
4	Hall B	blue	Hall sensor B
5	SGND	black	Signal GND
6	+5 V	red	VCC
7	Hall A	green	Hall sensor A
8	PH C	yellow	Motor phase C

In addition, a 9-pin SUB-D connector is attached, with the following assignment:

Pin	Meaning
2	RxD
3	TxD
5	GND

3.3.3 MCDC 3003/06 S

The connections are indicated on the terminal strips and are assigned as follows:

Connector pin assignment, supply side

Connection	Designation	Meaning
1	TxD	RS232 TxD
2	RxD	RS232 RxD
3	AGND	Analog GND
4	Fault	Error output
5	AnIn	Analog input
6	+24 V	+24 V
7	GND	GND
8	3. In	3. input optional electronic supply U_B

Connector pin assignment, motor side

Connection	Designation	Meaning
1	Mot -	Motor -
2	Mot +	Motor +
3	SGND	Encoder GND
4	+5 V	Encoder VCC
5	Ch B	Encoder channel B
6	Ch A	Encoder channel A
7	4. In	4th input
8	5. In	5th input

In addition, a 9-pin SUB-D connector is attached, with the following assignment:

Pin	Meaning
2	RxD
3	TxD
5	GND

3 Installation

3.3 Connector pin assignment

Analog input (analog input, analog GND = AGND)

The analog input is implemented as a differential input. The analog GND should be connected to the power supply GND. This prevents the voltage drop in the supply cable from affecting the target velocity value.

The analog input has various uses, depending on the configuration:

- Presetting of target velocity value via analog voltage
- Presetting of target velocity value via PWM signal
- Current limitation value via analog voltage
- Presetting of target position via analog voltage
- Digital input for reference and limit switches
- Connection for an external encoder (Analog input to GND: Channel A / Analog GND to GND: Channel B) in gearing or BL encoder mode.

RS232 connections

The RS232 wiring is established via the connections RxD, TxD and the supply GND. The integrated RS232 interface allows direct connection with a PC with use of a null modem cable, in which the transmit cable (TxD) and the receive cable (RxD) are crossed.

Error output

The error output is characterised by the following characteristics:

- Switch that switches to GND (Open Collector)
- Output resistor in open state (High Level): 100 k Ω
- The switch is open in the event of error (High Level)
- Output current limited to approx. 30 mA, voltage in open state must not exceed the power supply (maximum UB)
- Short-circuit proof

The error output is activated in the following situations:

- Current limitation active
- Over-voltage controller active (power supply over 32 V)
- Power stage switched off due to over temperature

The error output connection can also be reconfigured for other functions:

- Pulse output (only MCBL, 3564...B CS)
- Digital output
- Limit switch input
- Rotational direction input

3 Installation

3.3 Connector pin assignment

3th input

This connection can be used as reference or digital input. The drive can also be optionally provided with separate electronics supply at this connection ex-works, enabling the motor voltage to be switched off independently of the electronics supply.

4th / 5th input (MCDC only)

These inputs can be used as digital and reference inputs.

3.4 RS232 wiring

Use a null modem cable in which the transmit cable (TxD) and the receive cable (RxD) are crossed, in order to connect the controller with the PC or control.

Wiring with one Motion Controller – command NET0

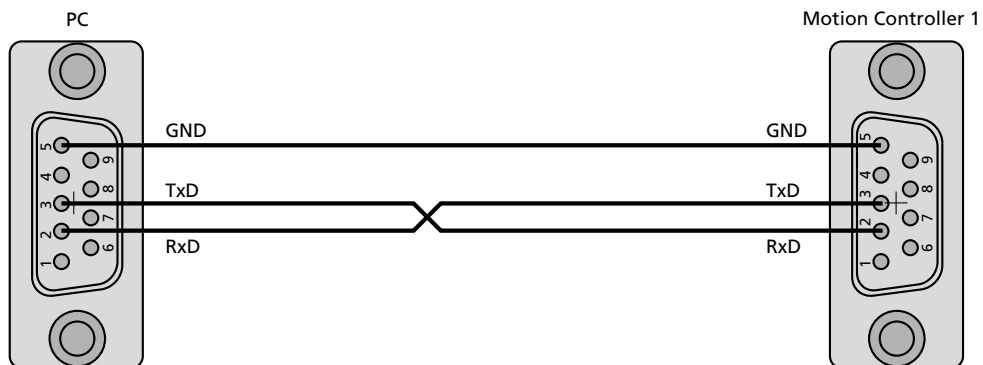

Wiring with several Motion Controllers – command NET1

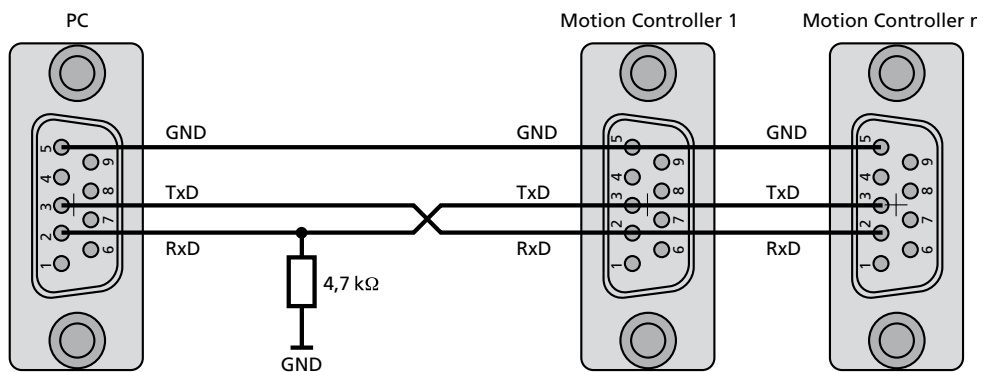

3 Installation

3.5 Motor wiring

MCDC 3003/06 S; MCBL 3003/06 S:

The encoder and signal lines are susceptible to interference, which makes it impossible to specify a maximum cable length.

Shielded wires must always be used with cable lengths > 300 mm.

It must be generally noted that the lines between the Motion Controller and the motor must be kept as short as possible, since drive system properties such as quietness and concentric running deteriorate as the length of the line increases.

MCDC 3003/06 S only:

The use of an encoder with complementary output (e.g. line driver) increases interference immunity. A HEDL adapter no. 6501.00064 from FAULHABER must be used in this case.

MCBL motor wiring

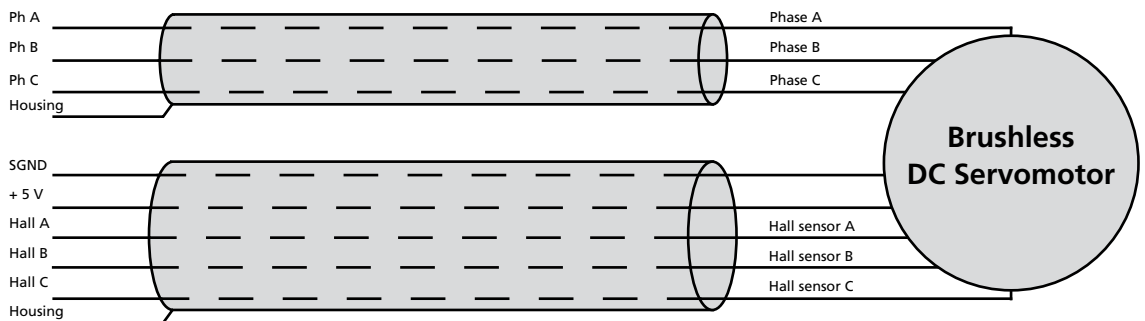

MCDC motor wiring

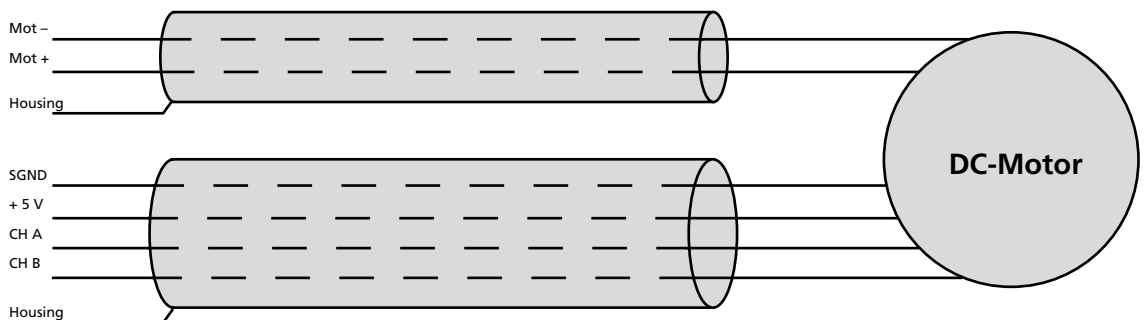

3 Installation

3.6 Baud rate and node number

The serial interface must be configured as follows:

- 8 data bits
- 1 stop bit
- No Parity

The Xon/Xoff protocol must be used for rapid command sequences or transfer of sequence programs and parameter sets.

The following transfer rates can be set:

- 600 baud (not supported by Motion Manager)
- 1200 baud
- 2400 baud
- 4800 baud
- 9600 baud (default)
- 19200 baud
- 38400 baud
- 57600 baud
- 115200 baud

The setting can be changed via the interface if a connection already exists with the drive node:

Command	Function	Description
BAUD	Select baud rate	Specify transfer rate for RS232 interface

Example:

Change transfer rate to 19200 baud:

BAUD 19200

CAUTION!



Baud rate

PC and controllers must be set to the same baud rate to enable them to communicate with each other.

- ▶ *If the baud rate of the controller has been changed, the baud rate of the PC or control must then also be set to the new baud rate.*

If several drives are to be operated on a serial interface, each drive unit must have a unique node number between 1 and 255.

Command	Function	Description
NODEADR	Define Node Address	Set node number

Example:

Set drive unit to node number 3:

NODEADR3

The devices are all delivered with node number 0. To prepare the units for network operation, they must first be individually connected to the PC and set to the required node address, e.g. with help of the FAULHABER Motion Manager.

3 Installation

3.6 Baud rate and node number

A serial network can be set up by connecting the transmit cable of the Master (PC, PLC) to the receive cable of the first node, from where it is looped through to the receive cable of the second node, and so on. The same procedure is followed with the receive cable of the Master, which is looped through to all transmit cables of the drive node. This generation of Motion Controllers does not require a multiplexer board for serial network operation. Multiplex mode is activated with a new command:

Command	Function	Description
NET	Set Network Mode	Activate RS232 multiplex mode for network operation. 0: No network operation, single drive on an RS232 1: Network operation activated

Example:

Activate network operation:

NET1

In order to address the individual drives in the network, the node number must be specified before each ASCII command to be sent (e.g. 3V100). Commands without a node number are adopted by all drive nodes in the network (Broadcast).

3 Installation

3.6 Baud rate and node number

CAUTION!



Simultaneous responses

If data is sent simultaneously by several devices, communication disturbance (interference) occurs.

- ▶ *No unaddressed query commands may be sent in network mode, as otherwise all units will answer simultaneously and the message frames will mix.*
- ▶ *Asynchronous (sporadic) responses may not be sent simultaneously by several devices.*
- ▶ *Switch off command acknowledgement if using unaddressed send commands.*

Use the ANSW command to set the response behaviour:

Command	Function	Description
ANSW	Answer Mode	0: No asynchronous responses 1: Allow asynchronous responses 2: All commands with confirmation and asynchronous responses 3: Debug mode, sent commands are returned (cannot be used if configuring with Motion Manager!) 4-7: analogous to 0-3, but responses resulting from a command in the sequence program are not sent (cannot be set via Motion Manager)

Example:

Switch off asynchronous responses and command confirmation:

ANSW0

Debug mode example:

Activate debug mode:

ANW3

Transmit: v100

Receive: v,100: OK

3 Installation

3.7 Basic settings

During initial commissioning of external Motion Controllers, a number of basic settings must be made in order to adjust the controller to the connected motor. Use the FAULHABER Motion Manager for easy execution of these adjustments.

CAUTION!



Risk of destruction

Failure to observe these basic settings can result in destruction of components!

► *The basic settings described in the following must be noted and observed.*

At delivery, the MCBL 3003/06 S is set to motor type 5 (2444S024B K1155) as a default. If you wish to connect another motor, you must set the correct motor type first of all. The FAULHABER Motion Manager offers the ability for enabling the Hall sensor signals to be synchronised for smooth starting and the phase angle to be optimised for best efficiency. This process should also be carried out during initial commissioning and whenever the motor is replaced ("Optimisation to connected motor" in the "Configuration – Drive functions" menu).

The controller parameters and current limitation values must also be adapted to the connected motor and the application.

The MOTTYP command adjusts the controller to the connected motor. Internal parameters are also changed for the specified values:

MOTTYP	Motor type	P term (POR)	I term (I)	PP	PD	CI	Peak current (mA)	Continuous current (mA)
1	1628T012B K1155	6	25	12	2	40	3 000	770
2	1628T024B K1155	9	22	8	10	40	3 000	410
3	2036U012B K1155	6	45	10	14	50	3 000	980
4	2036U024B K1155	14	25	17	6	50	3 000	480
5	2444S024B K1155	7	40	16	9	50	5 000	1 370
6	3056K012B K1155	8	30	22	13	50	7 000	1 940
7	3056K024B K1155	10	40	22	12	50	3 000	930
8	3564K024B K1155	8	40	12	6	50	8 000	2 800
9	4490H024B K1155	8	40	12	6	20	10 000	6 000
0	Special motor	10	50	10	5	40	10 000	5 000

The values set with the MOTTYP command can be individually changed later. With the RN command, the default parameters are set according to the set motor type. If a motor which is not included in the motor type list is to be connected, select motor type 0 (MOTTYP0) and also set the parameters k_n (speed constant) and R_m (connection resistance) in accordance with the information in the data sheet using commands **RN** and **RM**.

The MCDC 3003/06 S is set to an encoder resolution of 512 pulses (ENCRES 2048) as a default at delivery. 4 times the encoder resolution is entered (quadrature signal processing) via the **ENCRES** command or the Drive Parameters dialogue in the Motion Manager ("Configuration – Drive functions" menu).

Parameters R_m and k_n are used to protect the power output stage during braking operation. The values are given in the datasheet of the connected motor. The controller parameters and current limitation values must also be adapted to the connected motor and the application.

If using the Fault Pin as input (REFIN, DIRIN), the desired function must be programmed before applying external voltage!

3 Installation

3.8 Compatibility mode

Setting compatibility with previous models:

The following setting enables maximum compatibility with previous models (3564...BC, MCBL 2805, MCBL 2803, MCDC 2805 and MCDC 2803).

NOTE



Compatibility

The compatibility mode does not create complete compatibility with earlier Motion Controllers!

The following commands are required to set the compatibility:

- COMPATIBLE1
- SOR1
- SP10000
- SETTTL
- POR4
- I20
- PP15
- EN

Depending on the application, the controller parameters POR, I, PP, PD and SR may need to be readjusted (see chapter 4.8.6 Adjusting the controller parameters).

Explanation of the COMPATIBLE command

The following functions are executed by the COMPATIBLE command.

Command	includes the following functions	
COMPATIBLE1	ANSW1	Automatic command acknowledgements deactivated
	SR18	Controller sampling at 1.8 ms
	–	Encoder resolution reduced to 1 000 pulses/rev. (not MCDC).
COMPATIBLE0	ANSW2	Automatic command acknowledgement activated
	SR1	Controller sampling at 0.1 ms
	–	Encoder resolution is set to 3 000 pulses/rev. (not MCDC).

4 Functional description

The Motion Controllers can be configured for different operating modes.

As standard the drive unit is delivered as a servomotor with set value presetting via the serial interface. The drive can be reconfigured by means of the corresponding FAULHABER commands.

If the settings are to be permanently stored, the command SAVE (EEPSAV) must be executed after the configuration; this saves the current settings in the Flash data memory, from where they are reloaded when the unit is next switched on. The power stage must be activated (EN) for the drive to operate.

All commands and objects listed below are summarised and explained again in chapter 5 "Parameter Description".

The FAULHABER Motion Manager enables simple setting of the configuration parameters and operating modes via corresponding dialogue windows. The specified commands can be entered in plain text or selected from the Commands menu.

Circuit example:

3564K024B CS with reference switch at analog input

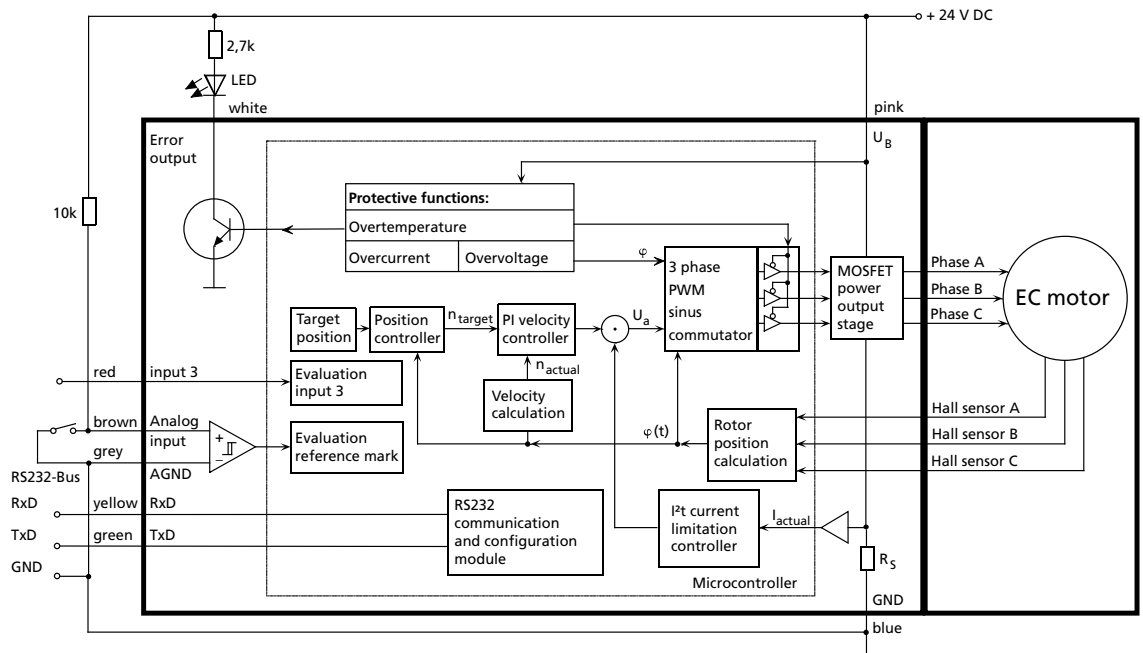

4 Functional Description

4.1 Position control

In this operating mode, target positions can be preset via the serial interface:

Setting: CONTMOD or ENCMOD and SOR0 operating mode

Profile and controller parameters are executed via the FAULHABER basic setting commands (see chapter 5.1.3 "General parameters"). In particular the acceleration values AC and DEC, the maximum speed SP, the current limitation values LPC and LCC, as well as the controller parameters POR, I, PP and PD must be adapted to the respective application. The positioning range limits can be set via the command LL and activated via APL.

The positioning is executed via the FAULHABER motion control commands:

Command	Function	Description
LA	Load Absolute Position	Load new absolute target position Value: $-1.8 \cdot 10^9 \dots 1.8 \cdot 10^9$
LR	Load Relative Position	Load new relative target position, in relation to last started target position. The resulting absolute target position must lie between the values given below. Value: $-2.14 \cdot 10^9$ and $2.14 \cdot 10^9$
M	Initiate Motion	Activate position control and start positioning

Example:

- 1.) Load target position: **LA40000**
- 2.) Start positioning: **M**

Attainment of the target position or any intermediate position is indicated by a "p" if "Notify Position" is set before the start of positioning, provided that ANSW1 or ANSW2 is set:

Command	Function	Description
NP	Notify Position	Without argument: A "p" is returned when the target position is attained. With argument: A "p" is returned when the specified position is overtravelled..
NPOFF	Notify Position Off	Notify Position command that has not yet been triggered is deactivated again.

If the linear Hall sensors of the brushless motors are used as position transducers (3564K024B CS, MCBL 3003/06 S), 3000 pulses per revolution are supplied. The COMPATIBLE1 command can be used to switch to 1000 pulses per revolution, in order to retain compatibility with the predecessor models (3564K024B C, MCBL 2805).

In COMPATIBLE1 mode, when the AC value is changed the DEC value is also set to the same value, and the positioning range limits divided by 3, additional the parameter SR will be changed from 1 to 18 (1.8 ms scanning rate from MC..2805). Independent for them, the user can readjust SR.

In the case of APL0, relative positioning can also be executed beyond the range limits. If the upper (1800000000) or lower limit (-1800000000) is exceeded, counting is continued at 0 without loss of increments.

4 Functional Description

4.1 Position control

Complex motion profiles

Complicated motion profiles can be generated through appropriate presetting of new values (maximum speed, acceleration, end position) during positioning. After a value change, simply execute a new motion start command (M). The commands NP and NV can be used to control the sequence.

Example:

Sequence (respective command sequences after receipt of the Notify condition):

Start:	a.)	b.)	c.)	d.)
LA[POS3]	AC[AC2]	AC[AC1]	SP[SP2]	DEC[DEC4]
AC[AC1]	NV[V2]	NP[POS1]	DEC[DEC3]	NP[POS3]
SP[SP1]	M	M	NP[POS2]	M
NV[V1]			M	
M				

The following diagram shows the described sequence.

Example of complex motion profile in comparison with trapezoidal profile:

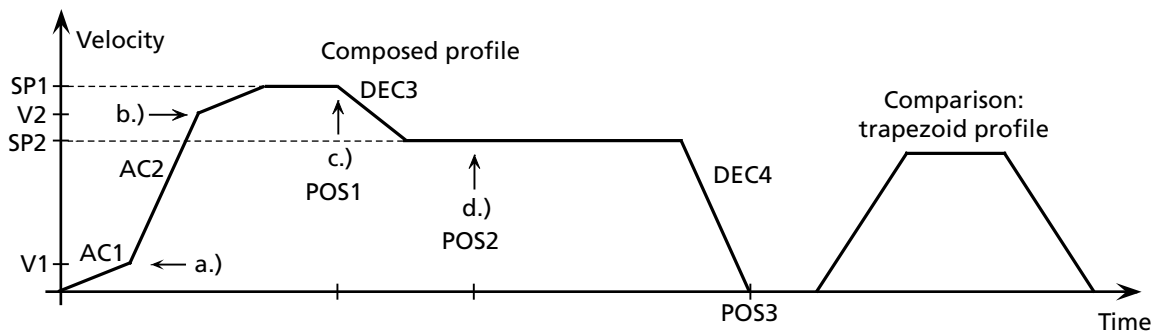

4 Functional Description

4.2 Velocity control

4.2.1 Velocity presetting via RS232

In this operating mode, the drive velocity can be controlled with set value presetting via RS232:

Setting: CONTMOD or ENCMOD and SOR0 operating mode

Profile and controller parameters are executed via the FAULHABER basic setting commands (see chapter 5.1.3 "General parameters"). In particular the acceleration values AC and DEC, the current limitation values LPC and LCC, as well as the controller parameters POR and I, must be adapted to the respective application.

The velocity control is executed with the following FAULHABER motion control command:

Command	Function	Description
V	Select Velocity Mode	Activate velocity mode and set specified value as target velocity (velocity control). Unit: rpm

Example:

Drive motor at 100 rpm: **v100**

In order to change the direction of rotation, simply assign a negative velocity value (e.g. V-100). V0 will stop the drive.

NOTE



Make sure that APL0 is set, if you do not want the drive to stop at the set range limits (LL)! Also check that the maximum speed SP is not set below the desired target velocity.

Reaching the given speed is indicated by a "v", if "Notify Velocity" has been set before starting the speed mode and ANSW1 or ANSW2 is set:

Command	Function	Description
NV	Notify Velocity	A "v" is returned when the nominal speed is reached or travelled through. Value: -32 767...32 767
NVOFF	Notify Velocity Off	Velocity command that has not yet been triggered is deactivated again.

Example:

When a speed of 1 000 rpm is reached or passed, a "v" is sent: **NV1000**

4 Functional Description

4.2 Velocity control

4.2.2 Analog velocity presetting

In this operating mode, the drive velocity can be controlled with set value presetting via an analog voltage.

Setting: CONTMOD and SOR1 operating mode (velocity presetting via voltage at analog input) or SOR2 (velocity presetting via PWM signal at analog input).

Profile and controller parameters are executed via the FAULHABER basic setting commands (see chapter 5.1.3 "General parameters"). In particular the acceleration values AC and DEC, the current limitation values LPC and LCC, as well as the controller parameters POR and I, must be adapted to the respective application. The analog velocity control can be further configured using the parameters described below:

Setting the scaling factor (maximum speed):

Target velocity at 10 V.

Command	Function	Description
SP	Load Maximum Speed	Load maximum speed. Setting applies to all modes (except VOLTMOD) Unit: rpm

Example:

Set maximum speed so that with 10 V at the analog input the target velocity is 5 000 rpm:

SP5000

Setting the minimum velocity:

Minimum velocity that is preset when the start voltage is present.

Command	Function	Description
MV	Minimum Velocity	Specifies the lowest velocity Unit: rpm

Example:

Set minimum velocity to 10 rpm:

MV10

Setting the start voltage

Voltage from which the drive is to start.

Command	Function	Description
MAV	Minimum Analog Voltage	Specifies the minimum start voltage Unit: mV

Example:

The drive is only to start moving with voltages over 100 mV or below -100 mV at the analog input:

MAV100

Advantage:

As 0 mV is usually difficult to set at the analog input, 0 rpm is also not easy to implement. The dead band produced by the minimum start voltage prevents the motor from starting as a result of small interference voltages.

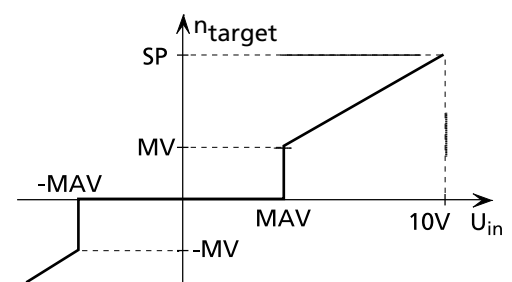

4 Functional Description

4.2 Velocity control

Setting the direction of rotation:

Command	Function	Description
ADL	Analog Direction Left	Positive voltages at the analog input result in anti-clockwise rotation of the rotor
ADR	Analog Direction Right	Positive voltages at the analog input result in clockwise rotation of the rotor

Example:

Clockwise rotation in the case of positive voltage: **ADR**

The error output (fault pin) can also be reconfigured as a digital rotational direction input:

Command	Function	Description
DIRIN	Direction Input	Use fault pin as rotational direction input

Level and direction:

Low: ... Left-hand rotation (corresponding to ADL command)

High: ... Right-hand rotation (corresponding to ADR command)

The level at the rotational direction input overrides the settings made with ADR and ADL. ADR and ADL are thus ineffective.

Set-point presetting via pulse width signal (PWM) at the analog input (SOR2):

At delivery:

- pulse duty factor > 50 % → Clockwise rotation
- pulse duty factor = 50 % → Stoppage
- pulse duty factor < 50 % → Anticlockwise rotation

The commands SP, MV, MAV, ADL and ADR can also be used here.

Make sure that APL0 is set, if you do not want the drive to stop at the set range limits.

NOTE



Input circuit

The input circuit at the analog input is designed as a differential amplifier. If the analog input is open, an undefined velocity can be set. The input must be connected to AGND with low-impedance or set to the voltage level of the AGND, in order to generate 0 rpm.

Simple set-point presetting via potentiometer, circuit example with 3564K024B CS:

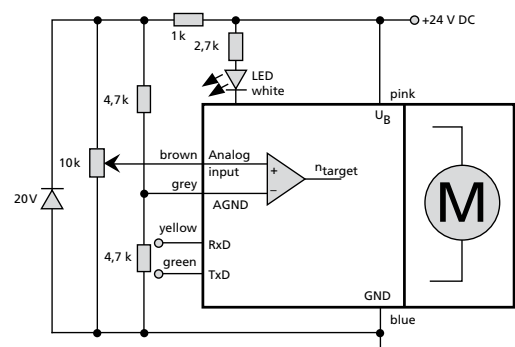

4 Functional Description

4.3 Homing and limit switches

The connections

- AnIn
- Fault
- 3., 4., 5. In, if available

can be used as reference and limit switch inputs.

In BL motors the zero crossing of the Hall sensor signals is also available as index pulse, occurring once per revolution. The index pulse of an external encoder can also be connected to the fault pin, enabling the actual position to be exactly zeroed.

The AnIn and Fault connections are designed as interrupt inputs, which means that they are edge-triggered. All other inputs are not edge-triggered, so that the signal must be at least 500 µs to be reliably detected. The maximum reaction time to level changes at all inputs is 500 µs.

Set levels of digital inputs:

Command	Function	Description
SETPLC	Set PLC inputs	Digital inputs PLC-compatible (24 V level)
SETTTL	Set TTL inputs	Digital inputs TTL-compatible (5 V level)

The signal level of the digital inputs can be set using the above commands:

PLC (Default): Low: 0...7.0 V/High: 12.5 V...U_B

TTL: Low: 0...0.5 V/High: 3.5 V...U_B

Configure fault pin as reference or limit switch input:

Command	Function	Description
REFIN	Reference Input	Fault pin as reference or limit switch input

The limit switch functions for the fault pin are only accepted if REFIN is activated (setting must be saved with SAVE or EEPsAV)!

CAUTION!



Configure before applying a voltage

The electronics can be damaged if a voltage is applied to the fault pin while it is not configured as input.

- ▶ *Configure the fault pin as input first before applying external voltage!*

The function of the inputs and the homing behaviour is set with the FAULHABER commands described below. A previously configured homing is then started with the following FAULHABER commands:

Command	Function	Description
GOHOSEQ	Go Homing Sequence	Execute FAULHABER homing sequence. A homing sequence is executed (if programmed) irrespective of the current mode.
GOHIX	Go Hall Index	Move BL motor to Hall zero point (Hall index) and set actual position value to 0 (not with MDCD)
GOIX	Go Encoder Index	Move to the encoder index at the Fault pin and set actual position value to 0 (DC motor or ext. encoder).
POHOSEQ	Power-On Homing Sequence	Start homing automatically after power-on. 1: Power-On Homing Sequence is activated 0: No homing after switch-on

4 Functional Description

4.3 Homing and limit switches

Configuration of homing and limit switches:

The following commands use the following bit mask for configuration of the limit switch functions:

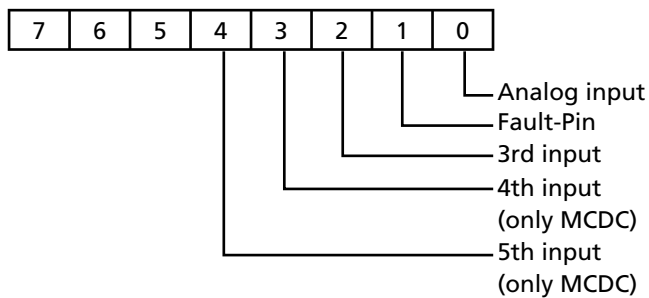

Set or delete the bit at the position of the required input for each command and assign the resulting numeric value to the commands described below.

Polarity and limit switch function:

Command	Function	Description
HP	Hard Polarity	Define valid edge and polarity of respective limit switches: 1: Rising edge and high level effective. 0: Falling edge and low level effective.
HB	Hard Blocking	Activate Hard Blocking function for relevant limit switch.
HD	Hard Direction	Presetting of direction of rotation that is blocked with HB of respective limit switch. 1: Clockwise rotation blocked 0: Anticlockwise rotation blocked

The Hard-Blocking function provides reliable protection against overshooting of the range limit switch. If the drive is located in an HB limit switch, then the direction of rotation set with HD will be blocked, i.e. the drive can only move further out of the limit switch.

The speed stays at 0 rpm if target velocities are preset in the wrong direction.

Example:

Setting of the Hard-Blocking function for Fault pin and 4th input: $2^1 + 2^3 = 2 + 8 = 10 \rightarrow \text{HB10}$

Definition of homing behaviour:

Command	Function	Description
SHA	Set Home Arming for Homing Sequence	Homing behaviour (GOHOSEQ): Set position value to 0 at edge of respective limit switch.
SHL	Set Hard Limit for Homing Sequence	Homing behaviour (GOHOSEQ): Stop motor at edge of respective limit switch.
SHN	Set Hard Notify for Homing Sequence	Homing behaviour (GOHOSEQ): Send a character to RS232 at edge of respective limit switch.

In order to be able to execute a homing sequence with the command GOHOSEQ, a homing sequence must be defined for a specific limit switch!

If the drive is already located in the limit switch when GOHOSEQ is invoked, first of all it moves out of the switch, in the opposite direction to that specified for HOSP.

4 Functional Description

4.3 Homing and limit switches

Example:

Homing with 3rd input as reference input (rising edge):

HP4

SHA4

SHL4

SHN4

Alternatively, the homing sequence can also be set with the command CAHOSEQ in conjunction with the commands HA, HL and HN.

Homing Speed:

Command	Function	Description
HOSP	Load Homing Speed	Load speed and direction of rotation for homing (GOHOSEQ, GOHIX). Unit: rpm

Example:

HOSP-100

Direct programming via HA, HL and HN commands:

Command	Function	Description
HA	Home Arming	Set position value to 0 and delete relevant HA bit at edge of respective limit switch. Setting is not saved.
HL	Hard Limit	Stop motor and delete relevant HL bit at edge of respective limit switch. Setting is not saved.
HN	Hard Notify	Send a character to RS232 and delete relevant HN bit at edge of respective limit switch. Setting is not saved.

These special commands can be used to define actions that are to be triggered at an edge of the relevant input, independently of a homing sequence. A programmed limit switch function will remain effective until the preselected edge occurs. The programming can be changed with a new command before an edge occurs.

The settings are not saved with the SAVE command, so all limit switches are inactive again after switch-on.

HL/SHL command:

Positioning mode: When the edge occurs, the motor positions itself on the reference mark with maximum acceleration.

Velocity controller mode: The motor is decelerated at the set acceleration value when the edge occurs, i.e. it goes beyond the reference mark. The reference mark can be precisely approached with a subsequent positioning command (command M).

Advantage: No abrupt motion changes.

HN command:

Hard Notify (HN) return values to the RS232 interface

Connection	Return value
"AnIn"	h
"Fault"	f
"3.In"	t
"4.In" (only MCDC)	w
"5.In" (only MCDC)	x

4 Functional Description

4.4 Enhanced operating modes

Use the CONTMOD command to revert from an enhanced operating mode to normal mode.

4.4.1 Stepper motor mode

Command	Function	Description
STEPMOD	Stepper motor mode	Change to stepper motor mode

In stepper motor mode, the analog input acts as frequency input. The error output must be configured as rotational direction input if the direction of rotation is to be changed via a digital signal. Alternatively, the direction of rotation can also be preset via the commands ADL and ADR.

Command	Function	Description
DIRIN	Direction Input	Fault pin as rotational direction input

The drive moves one programmable angle further for each pulse at the analog input, and thus simulates the function of a stepper motor.

There are a number of considerable advantages in comparison with a real stepper motor:

- The number of steps per revolution is freely programmable and of a very high resolution (encoder resolution)
- The individual step widths are freely programmable
- No detent torque
- The full dynamics of the motor can be used
- The motor is very quiet
- The motor monitors actual position so that no steps are "lost" (even with maximum dynamics)
- No motor current flows in settled state (actual position reached)
- High efficiency
- The control electronics are already integrated in the 3564K024B CS

Input:

Maximum input frequency: 400 kHz

Level: 5 V TTL or 24 V PLC-compatible, depending on configuration.

Stepper motor mode enables position-accurate velocity control; any rational ratios can be set for input frequency to motor speed, via step width and step number, in accordance with the following formula:

$$\text{Revolutions} = \text{pulses} \frac{STW}{STN}$$

Revolutions	... Revolutions that are generated on the drive
Pulses	... Number of pulses at the frequency input (=number of steps)
STW	... Step width (step width factor = number of steps per encoder pulse at the frequency input)
STN	... Step number (number of steps = number of steps per revolution)

Value range of STN and STW: 1 to 65 535

Command	Function	Description
STW	Load Step Width	Load step width for step motor and gearing mode
STN	Load Step Number	Load number of steps per revolution for step motor and gearing mode

4 Functional Description

4.4 Enhanced operating modes

Example:

Motor should turn 1/1000th of a revolution for each input signal:

STW1

STN1000

The acceleration and speed values (AC, DEC, SP) are also taken into account in step motor mode. These permit gentle starting and deceleration. The position range limits set via LL can also be activated with the APL1 command.

4.4.2 Gearing mode (electronic gear)

Gearing mode enables the use of an external encoder as set-point source for the position.

Command	Function	Description
GEARMOD	Gearing Mode	Change to gearing mode

The two channels of an external encoder are connected to connections AnIn and AGND, which may need to be connected to the 5 V encoder supply via a 2.7 kΩ pull-up resistor.

The gear ratio can be set in accordance with the following formula:

$$\text{Revolutions} = \text{pulses} \frac{STW}{STN}$$

- Revolutions ... Revolutions that are generated on the drive
- Pulses ... actually counted pulses which result in quadrature signal processing
- STW ... Step width (step width factor = number of steps per encoder pulse)
- STN ... Step number (number of steps = number of steps per revolution)

Value range of STN and STW: 1 to 65 535

Command	Function	Description
STW	Load Step Width	Load step width for step motor and gearing mode
STN	Load Step Number	Load number of steps per revolution for step motor and gearing mode

Example:

Motor has to move one revolution at 1000 pulses of the external encoder:

STW1

STN1000

The direction of rotation can be predefined with the commands ADL and ADR, or via an external signal at the fault pin (DIRIN command).

The acceleration and speed values (AC, DEC, SP) are also taken into account in gearing mode. These permit gentle starting and deceleration. The position range limits set via LL can also be activated with the APL1 command.

4 Functional Description

4.4 Enhanced operating modes

Circuit example, gearing mode for MCBL 3003/06 S

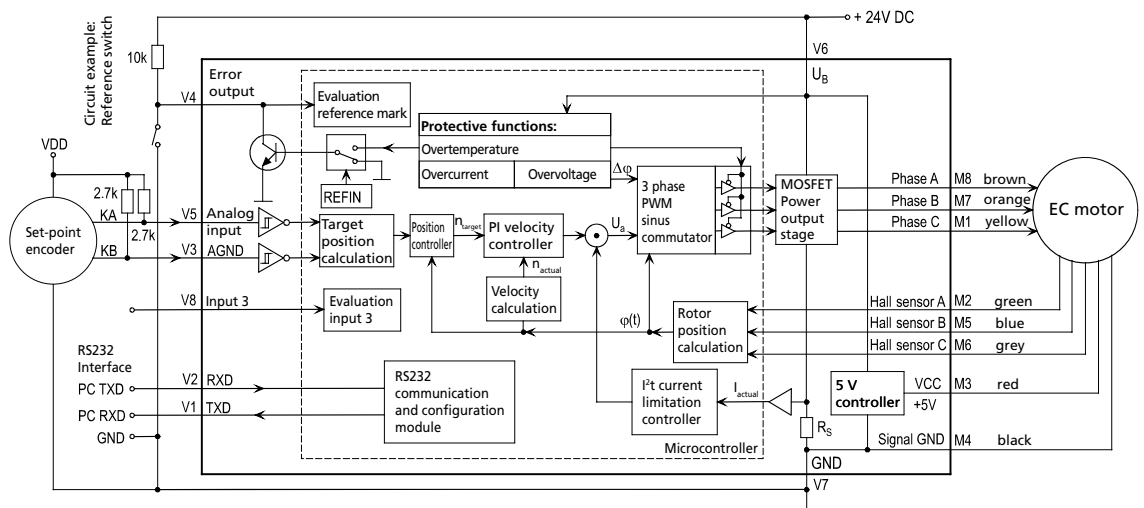

4.4.3 Analog positioning mode

In analog positioning mode, the position set-point can be preset via a potentiometer or an external analog voltage.

Command	Function	Description
APCMOD	Analog Position Control Mode	Change to position control via analog voltage

The maximum position to be approached with a voltage of 10 V can be preselected with the LL command. With a voltage of -10 V, the drive moves in the opposite direction, however, the negative position limit is never exceeded.

Command	Function	Description
LL	Load Position Range Limits	Load limit positions (the drive does not move out of these limits in positioning mode, positive values specify the upper limit and negative values specify the lower limit). APCMOD: Position value at 10 V

Irrespective of the preset LL value, the maximum position is limited to 3 000 000 (COMPATIBLE1 = 1 000 000) in APCMOD. Comment: The resolution of the analog input is limited to 12 bit (4096 steps).

The direction of rotation can be predefined with the commands ADL and ADR. The acceleration and speed values (AC, DEC, SP) are also taken into account in APCMOD. These permit gentle starting and deceleration.

Positioning via pulse width signal (PWM) at the analog input (SOR2):

If SOR2 is set in APCMOD, the pulse duty factor of a PWM signal can be used as position set-point.

At delivery:

- pulse duty factor > 50% → positive target position
- pulse duty factor = 50% → target position = 0
- pulse duty factor < 50% → negative target position

4 Functional Description

4.4 Enhanced operating modes

Absolute positioning within one revolution:

Thanks to the linear Hall sensors, the absolute position can be recorded within one revolution on BL motors. This means that even if the power supply is disconnected, the position determination supplies the correct position value after restarting (if the rotor has only been turned within one revolution).

The following commands enable the drive to be accurately positioned in the voltage range 0 V to 10 V within one revolution and to return to the correct position even after the supply has been switched off, without homing (not MCDC):

APCMOD ... change to analog positioning
 LL3000 ... Fix maximum position at 1 revolution (for COMPATIBLE1: LL1000)

4.4.4 External encoder as actual value (not MCDC)

For high-precision applications, the actual values of BL motors can be derived from an external encoder.

- The resolution of the position values is dependent on the resolution of the encoder in this case.
- Depending on the application, the velocity can be derived from the encoder or from the Hall sensors.
- The external encoder can be mounted directly on the motor shaft, but an encoder that is mounted to the application output (e.g. glass scale) is particularly advantageous. This allows the high precision to be set directly at the output.
- Commutation still occurs via the analog Hall sensors.

Command	Function	Description
ENCMOD	Encoder Mode	Change to encoder mode (not for MCDC) An external encoder serves as position transducer (the current position value is set to 0)
HALLSPEED	Hall sensor as speed sensor	Speed via Hall sensors in encoder mode (not for MCDC)
ENCSPPEED	Encoder as speed sensor	Speed via encoder in encoder mode (not for MCDC)

The two channels of the external encoder are connected to connections AnIn and AGND, which may need to be connected to the 5 V encoder supply via a 2.7 kΩ pull-up resistor.

The maximum limit position (value preset with the LL command) covers the value range from 0 to 1 800 000 000 for the positive and 0 to -1 800 000 000 for the negative limit position.

Input:

Maximum input frequency: 400 kHz
 Level: low 0...0.5 V / high 3.5 V... U_B

Set encoder resolution:

Command	Function	Description
ENCRES	Load Encoder Resolution	Load resolution of external encoder. (4 times pulse/rev.). Value: 8 to 65 535

Example:

External encoder with 512 pulses: **ENCRES2048**

Because of the quadrature signal processing, four times the number of pulses must always be specified for ENCRES.

4 Functional Description

4.4 Enhanced operating modes

4.4.5 Voltage regulator mode

If the drive is to operate as a pure voltage regulator, this can be configured with VOLTMOD. The motor voltage is then output proportionally to the preset value. The current limitation remains active.

With this mode, it is possible to use a higher level controller. The Motion Controller then serves only as a power amplifier.

Command	Function	Description
VOLTMOD	Set Voltage Mode	Activate Voltage Regulator Mode
U	Set Output Voltage	Output motor voltage (corresponds to $-U_v \dots +U_v$) with SOR0 only Value: -32 767...32 767

Three ways exist for specifying the target value for the output voltage: RS232 Interface, voltage at the analog input and PWM signal at the analog input.

SOR0 must be set to use the RS232 interface for command value.

The command U sets the output voltage proportional to the supply voltage. A value of 32 767 passes the full power supply voltage to the motor. A value of 0 passes 0 V to the motor. A value of $-32\,767$ passes the full power supply voltage inverted.

SOR1 must be set to use an analog voltage for command value.

The analog input voltage sets the output voltage scaled to the operating voltage. With a voltage of 10 V, the full power supply voltage is passed to the motor. A value of 0 V passes 0 V to the motor. A value of -10 V passes the full power supply voltage inverted.

SOR2 must be set to use a PWM signal for command value.

A 100 % duty cycle passes the full power supply voltage to the motor. A 50 % duty cycle passes 0 V to the motor. A 0 % duty cycle passes the full power supply voltage inverted.

4.4.6 Analog target current presetting

You can switch to analog target current presetting with the SOR3 command. The limitation current is then proportional to the voltage at the analog input, and the internal I^2t current limitation is deactivated. The set current is weighted with the maximum current LPC.

If 10 V are present at the analog input, the current is accordingly limited to the maximum current set with LPC. Even if negative voltages are present at the analog input, the current is limited to the amount of the applied voltage. Negative target current presettings therefore have no effect on the direction of rotation!

4.4.7 IxR control for DC controllers

For speed-controlled applications with DC motors without an encoder, an IxR control is available on the MCDC. In this mode, the motor speed is determined via an internal motor model. Consequently, the encoder and the associated wiring can be omitted. However, control quality and accuracy are considerably restricted. This mode is mainly suited for higher speeds and larger motors in the FAULHABER range.

Command	Function	Description
IXRMOD	Set IxR Mode	Activate IxR control (MCDC only)
RM	Load Motor Resistance	Load motor resistance R_m in accordance with information in the data sheet. Unit: $m\Omega$
KN	Load Speed Constant	Load speed constant k_n in accordance with information in the data sheet. Unit: rpm/V

4 Functional Description

4.5 Special functions of the error connection

The error connection (fault pin) can be configured as input or output for different tasks:

Command	Function	Description
ERROUT	Error Output	Fault pin as error output
ENCOUT	Encoder Output	Fault pin as pulse output (not MCDC):
DIGOUT	Digital Output	Fault pin as digital output. The output is set to low level.
DIRIN	Direction Input	Fault pin as rotational direction input
REFIN	Reference Input	Fault pin as reference or limit switch input

The REFIN and DIRIN functions have already been explained in the relevant chapters.

Fault pin as error output:

In ERROUT mode the output is set as soon as one of the following errors occurs:

- One of the set current limitation values (LPC, LCC) is exceeded
- Set maximum permissible speed deviation (DEV) is exceeded
- Overvoltage detected
- Maximum coil or MOSFET temperature exceeded

In order to hide the transient occurrence of errors during the acceleration phase, for example, an error delay can be set which specifies how long an error must be present before it is displayed at the error output:

Command	Function	Description
DCE	Delayed Current Error	Delayed error output for ERROUT in 1/100 sec.

Example:

Wait 2 seconds before displaying error: DCE200

If one of the above errors occurs, automatic notification with an "r" can be implemented by setting "Notify Error", provided that ANSW1 or ANSW2 is set:

Command	Argument	Function	Description
NE	0-1	Notify Error	Error notification: 1: An "r" is returned if an error occurs 0: No error notification

Fault pin as pulse output (not for MCDC):

In the ENCOUT mode the fault pin is used as pulse output, which outputs an adjustable number of pulses per revolution. The pulses are derived from the Hall sensor signals of the BL motors and are limited to 4000 pulses per second.

Command	Function	Description
LPN	Load Pulse Number	Preset pulse number for ENCOUT. Value: 1 to 255

Example:

Output 16 pulses per revolution at the fault pin: LPN16

In the case of 5000 rpm, $5000/60 \cdot 16 = 1333$ pulses per second are output.

For speeds that would generate more than the maximum possible pulse number at the set LPN value, the maximum number is output. The set pulses are precisely achieved, but the timing does not necessarily have to exactly agree (delays possible). Position determination via pulse counting is therefore possible, provided that no change occurs in the direction of rotation and the maximum possible pulse number is not exceeded.

Fault pin as digital output:

In DIGOUT mode, the error connection can be used as universal digital output. The digital output can be set or cleared via the following commands.

4 Functional Description

4.5 Special functions of the error connection

Command	Function	Description
CO	Clear Output	Set digital output DIGOUT to low level
SO	Set Output	Set digital output DIGOUT to high level
TO	Toggle Output	Switch to digital output DIGOUT

4 Functional Description

4.6 Sequence programs

Sequence programs that are stored directly in the data flash memory of the controller and executed from there can be created for stand-alone applications or for partially autonomous sequences.

The sequence programs can be created and transferred with the FAULHABER Motion Manager, but it is also possible to use a standard text editor and to subsequently transfer the programs with the Motion Manager or a terminal program.

During a program sequence commands can still be sent via the RS232. Almost all ASCII commands can be used in motion programs.

The command PROGSEQ can also be used in the network with a preceding node number. The subsequent command must be send also with a preceding node number. The addressed node stores all received instructions thereby, between the commands PROGSEQ and END.

Command	Argument	Function	Description
PROGSEQ [...] END	-	Program Sequence	<p>Defines the start and end of the sequence program.</p> <p>All commands sent to PROGSEQ are not executed, but transferred to the sequence program memory. An END marks the end of the sequence program.</p> <p>All commands after END are directly executed again.</p> <p>There is no SAVE command necessary for saving the program sequence.</p> <p>Command must not be executed more than 10,000 times, as otherwise the function of the Flash memory can no longer be guaranteed.</p> <p>These commands do not have to be entered in the FAULHABER Motion Manager, as they are automatically attached by the "Transfer program file..." function.</p> <p>Note: The Xon/Xoff protocol must be used to transfer lengthy program sequences</p>
GPROGSEQ	-/1	Get Program Sequence	<p>Reads out and sends back the stored program sequence. Each program line is output in lower case letters, ending with a CR character. At the end of the program the line "end:" is sent, with specification of the program length in bytes followed by a CR and LF character.</p> <p>GPROGSEQ1: Reads out the program sequence and indicates at which program line the program counter is currently located ("PC--")</p>
ENPROG	-	Enable Program	<p>Execution of the program is released, i.e. the sequence is started. This status can be permanently stored with SAVE/EEPSAV, so that the drive starts up with the stored program sequence immediately after switch-on.</p>
DIPROG	-	Disable Program	<p>Deactivate program execution.</p>
RESUME	-	Resume	<p>Continue program sequence after DIPROG at the point at which it was interrupted.</p>
MEM	-	Memory	<p>Return available program memory in Word.</p>

Control of sequence programs

There are a number of additional commands for controlling programs which are only useful within sequence programs and are consequently only available there.

4 Functional Description

4.6 Sequence programs

The following commands stop the sequence until the relevant position is reached:

NP ... Notify position

The sequence stops at the next M or V command, until the relevant position is reached.

HN ...Hard Notify

The sequence stops at the GOHOSEQ command or at the next M or V command, until the limit switch is overtravelled.

NV ...Notify Velocity

The sequence stops at the next M or V command, until the relevant speed is reached.

GOHIX ...Go Hall Index

The sequence stops at the GOHIX command, until the Hall null position is reached.

If there are several Notify conditions, the first fulfilled condition effects continuation of the program.

4 Functional Description

4.6 Sequence programs

Additional commands for use within sequence programs:

Command	Argument	Function	Description
DELAY	Value	Delay	Stop sequence for a defined time Argument: in 1/100 seconds Value: 0 to 65535
TIMEOUT	Value	Timeout	With Notify commands, only wait for the specified time and then continue the sequence again. Can also be used via RS232: Send an "o" if Notify condition has not been fulfilled. Argument: in 1/100 seconds Value: 0 to 65535
JMP	Adr	Jump	Jump to specified address. (Can also be used via RS232). Address: 0...255
JMPGx	Adr	Jump if greater than x	Jump to the specified address if result of last query command is greater than variable x (A, B, C). Address: 0...255
JMPLx	Adr	Jump if less than x	Jump to the specified address if result of last query command is less than variable x (A, B, C). Address: 0...255
JMPEx	Adr	Jump if equal x	Jump to specified address if result of last query command is equal to variable x (A, B, C). Address: 0...255
JPH	Adr	Jump if Hard-Input activated	Jump to the specified address if the analog input is active (HP determines the polarity). Address: 0...255
JPF	Adr	Jump if Hard-Input activated	Jump to the specified address if the Fault Pin input is active (HP determines the polarity). Fault Pin must be configured as input (REFIN). Address: 0...255
JPT	Adr	Jump if 3. Input activated	Jump to the specified address if the 3rd input is active (HP determines the polarity). Address: 0...255
JPD (only MCDC)	Adr	Jump if 4. Input activated	Jump to the specified address if the 4th input is active (HP determines the polarity). Address: 0...255
JPE (only MCDC)	Adr	Jump if 5. Input activated	Jump to the specified address if the 5th input is active (HP determines the polarity). Address: 0...255
SETx	Value	Set Variable x	Set variable x (A, B, C) to the specified value. Value: Int32 Without argument: Result of last query command is loaded into the variable. Value: - 2147483648 ... + 2147483647
GETx	-	Get Variable x	Query content of variable x (A, B, C).
ADDx	Value	Add to Variable x	Add or subtract variable x (A, B, C) with given value. Value: - 2147483648 ... + 2147483647
SETARGx	-	Set argument	Set value of variable x (A, B, C) as argument for the next command (if no argument is given there).
DxJNZ	Adr	Decrement x, Jump if not Zero	Decrease the value of variable x (A, B, C) by one and jump to specified address if the value is not 0. Address: 0...255
ERI	Adr	Error Interrupt	An error interrupt is activated from execution of this command. This means that if an error subsequently occurs (overvoltage, current limitation...), then the sequence branches to the specified address. The error handling mode is ended if a JMP or RETI command is executed. Address: 0...255

4 Functional Description

4.6 Sequence programs

Command	Argument	Function	Description
RETI	–	Return Error Interrupt	Return from an error handling routine. Important: the interrupted command is not continued, even if it was not completed at the time of interruption!
DIERI	–	Disable Error Interrupt	The ERI command is deactivated, i.e. in the event of an error the program does not jump to the error handling routine.
CALL	Adr	Call Subroutine	Call a subroutine at specified address. Address: 0...255
RET	–	Return from Subroutine	Return from a subroutine. Please note that only one subroutine level is possible, i.e. no subroutines can be called within subroutines!
A	Adr	Define Address	Definition of current position as entry address for jump commands. Address: 0...255

4 Functional Description

4.6 Sequence programs

Explanations of the commands and functions:

Jump commands

The program sequence can be specifically controlled with the jump commands.

The JMP command can also be used from the RS232. This is useful in cases where different program routines are to be called from the computer.

Example:

A1

JMP1 ... Endless loop

A2 ... Program sequence 2 (can only be called by JMP2 from the RS232)

LA10000

NP

M

JMP1 ... Return to endless loop

A3 ... Program sequence 3 (can only be called by JMP3 from the RS232)

LA-10000

NP

M

JMP1 ... Return to endless loop

The program sequences according to A2 or A3 can only be called by a JMP2 or JMP3 command from the RS232. A JMP2 from the RS232 results in the drive moving to position 10000 and stopping there.

The DxJNZ commands serve to form loops with a predefined number of cycles.

Example:

Move by the same relative position 5 times.

SETA5 ... Set variable A to the value 5

A2 ... Define jump address 2

LR100 ... Load relative position

NP ... Notify Position

M ... Start positioning

DAJNZ2 ... Decrease A by 1 and jump to address 2, provided that variable A is not yet 0.

The commands JPH, JPF and JPT enable jumps that are only executed if the relevant input is active. This means that programs can be called via external switches.

The commands JMPGx, JMPLx, JMPEx enable jumps that refer to the result of the last query command.

Example:

SETA 100

GN

JMPLA3

4 Functional Description

4.6 Sequence programs

The command JMPLA3 jumps to address 3 if the velocity value returned with GN is less than 100 rpm (value of variable A).

Entry addresses are defined via command A. In the case of a jump, the sequence is continued at this point.

The value range for jump commands extends from 0 to 255. Accordingly, a maximum of 256 different entry points can be defined with JMP, JPx, ERI and CALL.

Error Interrupt

During execution of the ERI command, nothing happens initially. Only if an error situation subsequently occurs does the sequence jump immediately to the specified address. This enables sensible continuation of the program in the event of error.

The RETI command enables you to return to the position at which the sequence was interrupted. Please note that the interrupted command is no longer executed, but is continued with the next command.

No new error interruption can take place within the error handling routine. The error handling status is cancelled as soon as the RETI or JMP command is executed. After this, the commands are interrupted again if an error occurs. It should therefore be ensured that the error situation disappears in the error handling routine. Otherwise, the error handling call will be repeated.

Homing

The HN/SHN command enables you to stop the sequence until the limit switch is reached. In order to correctly execute the GOHOSEQ command within a sequence, it is essential to set the SHN command accordingly when defining the homing sequence. This is necessary particularly if you wish to use the Power-On Homing sequence (POHOSEQ1).

Notify commands

Notify commands enable you to generate complicated motion profiles.

Example:

LA100000

SP5000

AC50

NV1000

M

AC100

NV2000

M

AC50

NP

M

With this sequence, the acceleration is increased during boot-up at 1000 rpm. It is decreased again at 2000 rpm.

NOTE



The NP command without argument stops the sequence until the target position is reached.

4 Functional Description

4.6 Sequence programs

The CALL command

The CALL command enables subroutines to be called from different points, any number of times. You can only jump back from a subroutine again with the RET command.

All commands are permitted within a subroutine except for a repeated CALL command.

General

If a sequence program is completely processed (no jump at the end of a program), then an "n" is sent to the RS232, if ANSW1 or ANSW2 is set.

In order to generate an endless program (useful for standalone operation), a jump command is required at the end of the program.

Memory size

The sequence programs are stored in binary coding in the Flash memory; 2 bytes are stored for each command, and 0 to 4 bytes for the argument. The maximum memory size available for sequence programs is 6656 bytes (3328 words).

Examples:

1.) Positioning routines called via RS232

The program enables the calling of different routines from the RS232 interface:

- **JMP2:** Homing Sequence. First move to a limit switch and then to the Hall sensor zero point (Hall index), in order to obtain the most precise reference point possible.
- **JMP3:** Move to position 0 and stop there.
- **JMP4:** Attempt to approach a position with low current limitation. As there may be an obstacle in the way in the application, the target position may not be attained. The motor should be stopped after 5 seconds, in any event. (Further evaluation occurs in the higher level control).
- **JMP5:** 1000 cycles with following sequence: 10 revolutions forwards, 1 second pause, 5 revolutions back again and then 0.5 seconds pause.

Configuration:

SOR0	... Digital velocity presetting via RS232
LR0	... Set current position as target position
M	... Switch to position control (Motion 0)
SHA1	... Homing Sequence with Notify at AnIn
SHN1	
SHL1	
HOSP200	... Homing speed 200 rpm
HP1	... Rising edge at limit switch effective
ENPROG	... Start motion program after power-on
ANSW0	... No asynchronous responses
EEPSAV	... Save configuration

4 Functional Description

4.6 Sequence programs

Program:

```

A1
JMP1      ... Endless loop
A2        ... Entry point for homing sequence (JMP2)
GOHOSEQ   ... Homing to reference switch
GOHIX     ... Subsequent homing to Hall sensor zero point (Hall index)
JMP1      ... Return to endless loop
A3        ... Entry point for routine 1 (JMP3)
LA0       ... Set target position to 0
NP        ... Notify at target position (sequence stops until target position is reached)
M         ... Start positioning
JMP1      ... Return to endless loop
A4        ... Entry point for routine 2 (JMP4)
LPC500    ... Set current limitation values to 500 mA (continuous current ≤ peak current)
LA1000000
NP
TIMEOUT500 ... Continue sequence after 5 sec., even if position has not yet been attained
M         ... Start positioning
V0        ... Stop motor
LR0
M         ... Switch back to positioning mode
JMP1      ... Return to endless loop
A5        ... Entry point for routine 3 (JMP5)
SETA1000 ... Predefine variable A
A6        ... Entry point for loop
LR30000
NP
M
DELAY100
LR-15000
NP
M
DELAY50
DAJNZ 6   ... Repeat loop 1000 times
JMP1      ... Return to endless loop
  
```

NOTE



The individual routines are called from the serial interface by sending the commands "JMP2", "JMP3", etc..

If the sequence is to wait until the end of a motion command (M, GOHOSEQ, etc.), a Notify (NP or SHN1 in the Homing Sequence configuration) must be set first of all.

4 Functional Description

4.6 Sequence programs

2.) Sequence controlled via digital input (without RS232)

- After power-on, the drive moves to the limit switch and then the Hall index.
- With a positive edge at the fault pin digital input, the drive moves forward 5000 increments.
- If the level is still high after 5000 increments, the drive moves to position 0.

Configuration

SOR0	... Digital velocity presetting via RS232
LR0	... Set current position as target position
M	... Switch to position control (Motion 0)
REFIN	... Reprogram error output to input
SHA1	... Homing Sequence with Notify at Input 1 (AnIn)
SHN1	
SHL1	
HOSP-200	... Homing velocity 200 rpm backwards
HP1	... Rising edge at limit switch (Input 1) effective
POHOSEQ1	... Execute Homing Sequence after power-on
ENPROG	... Start motion program after power-on
ANSW0	... No asynchronous responses
EEPSAV	... Save configuration

Program

GOHOSEQ	... Homing to reference switch
GOHIX	... Subsequent homing to Hall sensor zero point (Hall index)
A1	
HP3	... High level at input 2 (Fault pin input) and input 1 (AnIn) effective
A2	
JPF2	... Endless loop until low level at input 2
HP1	... Low level effective at input 2 (Fault pin input), input 1 (AnIn) continued high level
A3	
JPF3	... Endless loop until high level at input 2 (evaluation of positive edge)
LR5000	
NP	... Notify at target position (sequence stops until target position is reached)
M	... Move forward 5000 increments
DELAY50	... Wait 0.5 seconds until input 2 is queried
JPF1	... Jump back to start in case of low level at input 2
LA0	
NP	
M	... Move to position 0, if high level at input 2
JMP1	... Jump to start

NOTE



With this program, an RS232 interface is no longer required for operation (stand-alone application). The desired sequence is started with short pulses at the input (e.g. key) and the return is triggered with a continuous signal (e.g. switch).

4 Functional Description

4.7 Trace function

An efficient trace function is available via an additional binary interface. This allows up to 2 values to be read out online in a resolution of up to 3 ms.

In order to be able to use the binary interface, it must first have been opened for the desired node with the command BINSEND1.

Command	Argument	Function	Description
BINSEND	0 – 1	Open Binary Interface	1 = Open binary interface 0 = Close binary interface

Trace configuration:

- Setting of binary transmit mode for parameter 1 (curve 1):

2 binary characters are sent in direct succession: [Command][Mode1]

The relevant value is switched to, depending on the value of Mode1.

Command:

200: Set binary transmit mode for parameter 1

Mode 1:

- 0: Actual velocity [Integer16, rpm]
- 1: Target velocity [Integer16, rpm]
- 2: Controller output [Integer16]
- 4: Motor current [Integer16, mA]
- 44: Housing temperature [Unsigned16, °C]
- 46: Coil temperature [Unsigned16, °C]
- 200: Current position [Integer32, Inc]
- 201: Target position [Integer32, Inc]

- Setting of binary transmit mode for parameter 2 (curve 2):

2 binary characters are sent in direct succession: [Command][Mode2]

The relevant value is switched to, depending on the value of Mode2.

Command:

202: Set binary transmit mode for parameter 2

Mode 2:

- 0: Actual velocity [Integer16, rpm]
- 1: Target velocity [Integer16, rpm]
- 2: Controller output [Integer16]
- 4: Motor current [Integer16, mA]
- 44: Housing temperature [Unsigned16, °C]
- 46: Coil temperature [Unsigned16, °C]
- 200: Current position [Integer32, Inc]
- 201: Target position [Integer32, Inc]
- 255: No second parameter is sent (basic setting at power-on)

4 Functional Description

4.7 Trace function

Data request:

A binary character is sent: [Request]

Depending on the set modes (Commands 200 and 202), 3,5,7 or 9 bytes are sent back to the PC.

Request:

201: Request a data package

After setting a mode you must wait at least 2 ms before requesting valid data.

Received data (after request 201):

1.) Mode1 between 0 and 15, Mode2 at 255 (inactive)

- 3 byte... 1st byte: Low byte data
- 2nd byte: High byte data
- 3rd byte: Time code

The data are in Integer16 format.

2.) Mode1 between 16 and 199, Mode2 at 255 (inactive)

- 3 byte... Coding as in 1.)

The data are in Unsigned16 format.

3.) Mode1 between 200 and 255, Mode2 at 255 (inactive)

- 5 byte... 1st byte: Lowest byte data
- 2nd byte: Second byte data
- 3rd byte: Third byte data
- 4th byte: Highest byte data
- 5th byte: Time code

The data are in Integer32 format.

4.) Mode1 corresponding to 1.), 2.) or 3.) and Mode2 less than 255:

- 5 - 9 Byte ...Byte 1 to 2 (4): Data bytes of Mode1
- Byte 3 (5) to 4 (6) (8): Data bytes of Mode2
- Byte 5 (7) (9): Time code

The data bytes of Mode2 are coded as for Mode1.

The time code corresponds to a multiple of the time basis of 1 ms and defines the time interval to the last transmission. In Compatibility Mode (COMPATIBLE1), the time basis is 9 ms.

4 Functional Description

4.8 Technical information

4.8.1 Sinus commutation

The 3564K024B CS and the MCBL 3003/06 S are characterised by a so-called sinus commutation. This means that the preset rotating field is always ideally positioned in relation to the rotor. As a result, torque fluctuations can be reduced to a minimum, even at very low speeds. In addition, the motor runs particularly quietly.

In the current version, the sinus commutation has been enhanced to include so-called flat-top modulation, which enables 15 % more modulation. As a result, higher no-load speeds are possible.

With the SIN0 command, the system can even be set so that over 30 % more modulation is possible. In this mode, the sinus commutation in the upper speed range switches over to a block commutation. This full modulation enables the complete speed range of the motor to be utilised.

Command	Function	Description
SIN	Sinus commutation	0: Full modulation 1: Limited to sinusoidal form (basic setting)

4.8.2 Current regulator and I²t current limitation

The FAULHABER Motion Controllers are equipped with an integral current controller, which enables torque limitation.

The following parameters can be set:

Command	Function	Description
LPC	Load Peak Current Limit	Load peak current Value: 0 to 12 000 mA
LCC	Load Continuous Current Limit	Load continuous current Value: 0 to 12 000 mA
CI	Load Current Integral Term	Load integral term for current controller Value: 1...255

1.) Peak current

FAULHABER command:

LPC8000 ... Set peak current to 8000 mA

The current is limited to the peak current, provided that the thermal current model calculates a non-critical temperature.

2.) Continuous current

FAULHABER command:

LCC2800 ... Set continuous current to 2800 mA

If the thermal current mode reaches a critical temperature, the current is limited at the continuous current setting.

Mode of operation of the current controller:

When the motor starts, the peak current is preset as the set-point for the current controller. As the

4 Functional Description

4.8 Technical information

load increases, the current in the motor constantly increases until it finally reaches the peak current. The current controller then comes into operation and limits the current to this set-point.

A thermal current model operating in parallel calculates a model temperature from the actually flowing current. If this model temperature exceeds a critical value, continuous current is switched to and the motor current is regulated to this. Only when the load becomes so small that the temperature falls below the critical model temperature is peak current permitted again. The aim of this so-called I²t current limitation is to prevent heating of the motor beyond the thermally permissible temperature through appropriate selection of the continuous current. On the other hand, a high load should be temporarily possible in order to enable very dynamic movements.

Functioning of the I²t current limitation:

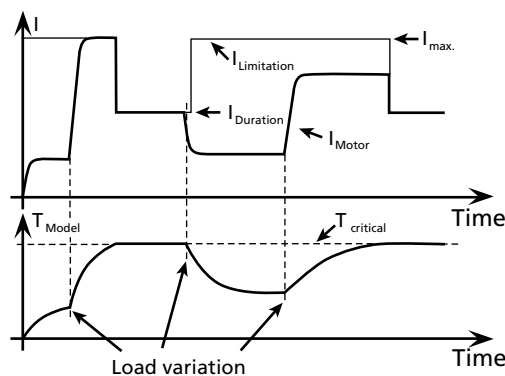

4.8.3 Overtemperature protection

If the MOSFET temperature of the external controllers or the coil temperature of the 3564K024B CS exceeds a preset limit value, the motor is switched off. The following conditions must be fulfilled in order to reactivate the motor:

- Temperature below an internal preset limit value
- Target velocity set to 0 rpm
- Actual motor speed less than 50 rpm

NOTE



Determining the coil temperature

The housing temperature is measured and the power loss concluded from the current measurement. The MOSFET or coil temperature is calculated from these values via a thermal model. In most applications, this method represents a thermal motor protection device.

4.8.4 Under-voltage monitoring

If the supply voltage falls below the lower voltage threshold, the power stage is switched off. The Motion Controller remains active. When the voltage returns within the permissible range, the power stage is switched on again immediately.

4 Functional Description

4.8 Technical information

4.8.5 Overvoltage regulation

If the motor is operated as a generator, it produces energy. Usually power supply units are not able to feed this energy back into the power line. For this reason, the supply voltage increases. Depending on the speed, the maximum allowable voltage can be exceeded.

In order to avoid severe damage to components, the 3564K024B CS and the MCBL 3003/06 S contain a controller which adjusts the rotor displacement angle if a limit voltage (32 V) is exceeded. The MCDC 3003/06 S contains a ballast circuit which is activated if a limit voltage (32 V) is exceeded. As a result, the energy generated in the motor is converted, and the voltage of the electronics remains limited to 32 V. This method protects the drive during generating operation and rapid braking.

4.8.6 Adjustment of the controller parameters

The controller parameters are already preset for common applications. However, in order to optimally adapt the controller to the respective application, the controller parameters must be optimized. Various theoretical and practical adjustment rules exist, but these will not be described in more detail here. A simple, practical method of adjusting the controller is explained below.

NOTE



Controller sampling rate

The digital controller operates at a sampling rate of 100 μ s. When needed the sampling rate can be increased up to 2 ms via the command SR.

The following controller parameters are available:

Command	Function	Description
POR	Load Velocity Proportional Term	Load velocity controller amplification. Value: 1 – 255.
I	Load Velocity Integral Term	Load velocity controller integral term Value: 1 – 255.
PP	Load Position Proportional Term	Load position controller amplification. Value: 1 – 255.
PD	Load Position D-Term	Load position controller D-term. Value: 1 – 255.
SR	Load Sampling Rate	Set the controller sampling rate (ms/10). Value 1...20

4 Functional Description

4.8 Technical information

Possible procedure:

a.) Set parameters of velocity controller:

- 1.) First of all you have to choose the right sampling rate for the velocity controller depending on the encoder resolution. With less encoder pulses, e.g. 64 pulses per revolution, you need a lower sampling rate e.g. 1.8 ms = SR18. For BL motors with internal encoder (3000 pulses per revolution) the maximum sampling rate SR1 is recommended.

Set initial configuration:

- Controller amplification = 8; POR8
- Integral term = 20; I20
- velocity at 1/3 of the maximum application velocity (example V1000)
- Set acceleration to highest tolerable value of the application (example AC10000)

- 2.) Increase controller amplification (step width 5, less subsequently); POR 13

- 3.) Preset velocity jump from 1/3 of maximum speed to 2/3 (example V2000)

- 4.) Velocity jump from 2/3 to 1/3 and monitor behaviour (example V1000)

- 5.) Repeat steps 2 to 4, until the controller becomes unstable. Then reduce controller amplification until stability is reliably ensured.

- 6.) Follow steps 2 to 5 with integral term.

b.) Set parameters of position controller:

- 1.) Set initial configuration

- Default value for P term: 8; PP8
- Default value for D term: 15; PD15

- 2.) Motion profiles appropriate for the application must now be run. If the system does not function stably with these settings, stability can be achieved by reducing the I term of the velocity controller or reducing the P term of the position controller.

- 3.) The P term of the position controller can now be increased until the system becomes unstable, in order to optimise the motion profile.

- 4.) The stability can then be reinstated using the following measures:

- Increasing the D term of the position controller (example: PD20)
- Reducing the I term of the velocity controller

Special mode for position control:

The SR command can be used to activate a special position control mode. To this end, the value 100 must be added to the required SR setting.

Example:

- Required SR10 setting
with special mode: **SR110**.

If this mode is activated, the parameter POR is successively reduced in a position-controlled application as soon as the drive is within the target corridor (can be set using the CORRIDOR command). This enables a much "gentler" stoppage to be achieved after reaching the target position. As soon as the drive is out of the target corridor position, POR is immediately increased again to the set value.

5 Parameter description

All ASCII commands that are available for operation of the FAULHABER Motion Controllers are listed below.

The ASCII commands have the following structure:

[Node No.]	Command	[Argument]	CR
------------	---------	------------	----

The node number is optional and is only required if several drives are being operated on one interface.

The command consists of a letter character string.

The optional argument consists of an ASCII numeric value. The end is always a CR character (Carriage Return, ASCII decimal code 13). Space characters are ignored, and no distinction is made between upper and lower case.

The response to query commands or asynchronous events is also an ASCII character string, followed by a CR character (Carriage Return, ASCII decimal code 13) and an LF character (Line Feed, ASCII decimal code 10).

Examples:

■ Actual position queries:

Transmit: POS [CR]

Receive: 98956 [CR] [LF]

■ Drive nodes at 500 rpm:

Transmit: V500 [CR]

If ANSW2 is set, you will receive an "OK" when the command has been successfully executed. If an execution error occurred you will receive one of the following character strings:

- "Unknown command"
- "Invalid parameter"
- "Command not available"
- "Overtemperature – drive disabled"

Example:

Transmit: V500 [CR]

Receive: OK [CR] [LF]

The SAVE / EEP5AV command always responds with the character string "EEPROM writing done" after successful saving of the current settings in the data Flash memory, or with "Flash defect", if the save has failed.

5 Parameter description

5.1 Basic setting commands

The commands listed here are used for the configuration of basic setting parameters.

5.1.1 Commands for special operating modes

Command	Argument	Function	Description
SOR	0 – 3	Source For Velocity	Source for velocity presetting 0: Serial interface (default) 1: Voltage at analog input 2: PWM signal at analog input 3: Current target value via analog input
CONTMOD	–	Continuous Mode	Switch back to normal mode from an enhanced mode
STEPMOD	–	Stepper motor mode	Change to stepper motor mode
APCMOD	–	Analog Position Control Mode	Change to position control via analog voltage
ENCMOD	–	Encoder Mode	Change to encoder mode (not for MCDC) An external encoder serves as position detector (the current position value is set to 0)
HALLSPEED	–	Hall sensor as speed sensor	Speed via Hall sensors in encoder mode (not for MCDC)
ENCSPPEED	–	Encoder as speed sensor	Speed via encoder signals in encoder mode (not for MCDC)
GEARMOD	–	Gearing Mode	Change to gearing mode
VOLTMOD	–	Set Voltage Mode	Activate Voltage Regulator Mode
IXRMOD	–	Set IxR Mode	Activate IxR control (MCDC only)

5.1.2 Parameters for basic setting

Command	Argument	Function	Description
ENCRES	Value	Load Encoder Resolution	Load resolution of external encoder (4 times pulse/rev). Value: 8 to 65 535
MOTTYP	0 – 9	BL motor type	Set to connected BL motor (MCBL only). 0: BL special motor according to KN and RM 1: 1628T012B K1155 2: 1628T024B K1155 3: 2036U012B K1155 4: 2036U024B K1155 5: 2444S024B K1155 6: 3056K012B K1155 7: 3056K024B K1155 8: 3564K024B K1155 9: 4490H024B K1155
KN	Value	Load Speed Constant	Load speed constant K_n in accordance with information in the data sheet. Unit: rpm/V. (Only necessary for MOTTYP0 or DC motor) Value: 0...16 383
RM	Value	Load Motor Resistance	Load motor resistance R_M according to specification in data sheet. Unit: m Ω . (Only necessary for MOTTYP0 or DC motor) Value: 10...320 000
STW	Value	Load Step Width	Load step width for step motor and gearing mode Value: 1...65 535
STN	Value	Load Step Number	Load number of steps per revolution for step motor and gearing mode Value: 1...65 535
MV	Value	Minimum Velocity	Presetting of minimum velocity in rpm for specification via analog voltage (SOR1, SOR2) Value: 0...30 000
MAV	Value	Minimum Analog Voltage	Specify minimum start voltage in mV for speed specification via analog voltage (SOR1, SOR2) Value: 0...10 000
ADL	–	Analog Direction Left	Positive voltages at the analog input result in anticlockwise rotation of the rotor (SOR1, SOR2)
ADR	–	Analog Direction Right	Positive voltages at the analog input result in clockwise rotation of the rotor (SOR1, SOR2)
SIN	0 – 1	Sinus commutation	1: No block commutation within the upper velocity range (default) 0: Block commutation within the upper velocity range (full modulation) (not for MCDC)

5 Parameter description

5.1 Basic setting commands

Command	Argument	Function	Description
NET	0 – 1	Set Network Mode	Activate RS232 multiplex mode for network operation. 0: No network operation, single drive on an RS232 1: Network operation activated
BAUD	Value	Select baud rate	Specify transfer rate for RS232 interface For value, see chapter 3.6 "Baud rate and node number"
NODEADR	Value	Define Node Address	Set node number Value: 0...255
COMPATIBLE	0 – 1	Set Compatible Mode	Set compatibility with previous models 0. Compatibility mode disabled 1: Compatibility mode enabled
ANSW	0 – 7	Answer Mode	0: No asynchronous responses 1: Allow asynchronous responses 2: All commands with confirmation and asynchronous responses 3: Debug mode, sent commands are returned (cannot be used if configuring with Motion Manager!) 4-7: analogous to 0-3, but responses resulting from a command in the sequence program are not sent (cannot be set via Motion Manager)

5.1.3 General parameters

Command	Argument	Function	Description
LL	Value	Load Position Range Limits	Load limit positions (the drive cannot be moved out of these limits). Positive values specify the upper limit and negative values the lower. The range limits are only active if APL1 is. Value: -1,8 · 10⁹...+1,8 · 10⁹
APL	0 – 1	Activate/Deactivate Position Limits	Activate range limits (LL) (valid for all operating modes except VOLTMOD). 1: Position limits activated 0: Position limits deactivated
SP	Value	Load Maximum Speed	Load maximum speed. Setting applies to all modes (rpm). Value: 0 to 30 000
AC	Value	Load Command Acceleration	Load acceleration value (r/s ²). Value: 0...30 000
DEC	Value	Load Command Deceleration	Load braking value (r/s ²). Value: 0...30 000
SR	Value	Load Sampling Rate	Load sampling rate of the velocity controller as a multiplier of 100 μs (ms/10). Value: 1...20
POR	Value	Load Velocity Proportional Term	Load velocity controller amplification. Value: 1...255
I	Value	Load Velocity Integral Term	Load velocity controller integral term. Value: 1...255
PP	Value	Load Position Proportional Term	Load position controller amplification. Value: 1...255
PD	Value	Load Position Differential Term	Load position controller D-term. Value: 1...255
CI	Value	Load Current Integral Term	Load integral term for current controller. Value: 1...255
LPC	Value	Load Peak Current Limit	Load peak current (mA). Value: 0...12 000
LCC	Value	Load Continuous Current Limit	Load continuous current (mA). Value: 0...12 000
DEV	Value	Load Deviation	Load maximum permissible deviation of actual velocity from target velocity (deviation) Value: 0...30 000
CORRIDOR	Value	Load Corridor	Window around the target position. Value: 1...32 767

5 Parameter description

5.1 Basic setting commands

5.1.4 Configuration of fault pin and digital inputs

Command	Argument	Function	Description
ERROUT	-	Error Output	Fault pin as error output
ENCOUT	-	Encoder Output	Fault pin as pulse output (not for MCDC):
DIGOUT	-	Digital Output	Fault pin as digital output. The output is set to low level.
DIRIN	-	Direction Output	Fault pin as rotational direction input
REFIN	-	Reference Input	Fault pin as reference or limit switch input
DCE	Value	Delayed Current Error	Delayed error output for ERROUT in 1/100 sec. Value: 0...65 535
LPN	Value	Load Pulse Number	Preset pulse number for ENCOUT. Value: 1...255
CO	-	Clear Output	Set digital output DIGOUT to low level
SO	-	Set Output	Set digital output DIGOUT to high level
TO	-	Toggle Output	Switch to digital output DIGOUT
SETPLC	-	Set PLC inputs	Digital inputs PLC-compatible (24 V level)
SETTTL	-	Set TTL inputs	Digital inputs TTL-compatible (5 V level)

5.1.5 Configuration of homing and limit switches in

Command	Argument	Function	Description
HP	Value	Hard Polarity	Define valid edge and polarity of respective limit switches: 1: Rising edge and high level effective. 0: Falling edge and low level effective.
HB	Value	Hard Blocking	Activate Hard Blocking function for relevant limit switch.
HD	Value	Hard Direction	Presetting of direction of rotation that is blocked with HB of respective limit switch. 1: Clockwise rotation blocked 0: Anticlockwise rotation blocked
SHA	Value	Set Home Arming for Homing Sequence	Homing behaviour (GOHOSEQ): Set position value to 0 at edge of respective limit switch.
SHL	Value	Set Hard Limit for Homing Sequence	Homing behaviour (GOHOSEQ): Stop motor at edge of respective limit switch.
SHN	Value	Set Hard Notify for Homing Sequence	Homing behaviour (GOHOSEQ): Send a character to RS232 at edge of respective limit switch.
HOSP	Value	Load Homing Speed	Load speed and direction of rotation for homing (GOHOSEQ, GOHIX, GOIX). Value: -30 000...30 000 rpm
POHOSEQ	0 - 1	Power-On Homing Sequence	Start homing automatically after power-on. 0: No homing after switch-on 1: Power-On Homing Sequence is activated
HA	Value	Home Arming	Set position value to 0 and delete relevant HA bit at edge of respective limit switch. Setting is not saved.
HL	Value	Hard Limit	Stop motor and delete relevant HL bit at edge of respective limit switch. Setting is not saved.
HN	Value	Hard Notify	Send a character to RS232 and delete relevant HN bit at edge of respective limit switch. Setting is not saved.

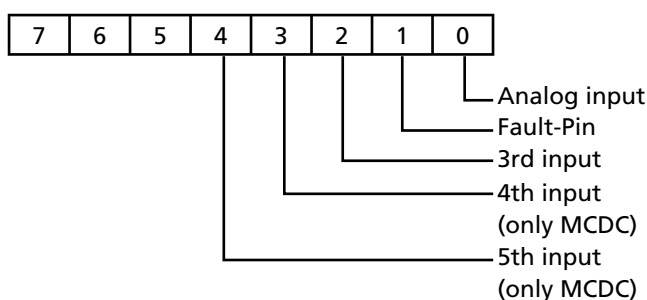

5 Parameter description

5.2 Query commands for basic setting

5.2.1 Operating modes and general parameters

Command	Argument	Function	Description																											
CST	-	Configuration Status	<p>Set operating mode.</p> <p>Return value is binary encoded (LSB = Bit 0):</p> <p>Bit 0, Compatible mode 0: COMPATIBLE0 1: COMPATIBLE1</p> <p>Bit 1–2: Automatic responses 0: ANSW0 (no automatic responses) 1: ANSW1 (asynchronous responses) 2: ANSW2 (additional command acknowledgements) 3: ANSW3 (Debug)</p> <p>Bit 3-4, Velocity presetting: 0: SOR0 (RS232 interface) 1: SOR1 (Analog voltage) 2: SOR2 (PWM signal) 3: SOR3 (current limitation value)</p> <p>Bit 5-6, reserved</p> <p>Bit 7-9, FAULHABER mode: 0: CONTMOD 1: STEPMOD 2: APCMOD 3: ENCMOD / HALLSPEED 4: ENCMOD / ENCSPEED 5: GEARMOD 6: VOLTMOD 7: IXRMOD</p> <p>Bit 10, Power amplifier: 0: Disabled (DI) 1: Enabled (EN)</p> <p>Bit 11, Position controller: 0: Switched off 1: Switched on</p> <p>Bit 12, Analog direction of rotation: 0: ADL 1: ADR</p> <p>Bit 13, Position Limits APL: 0: deactivated 1: activated</p> <p>Bit 14, Sinus commutation SIN: 0: Allow block commutation 1: Do not allow block commutation</p> <p>Bit 15, Network operation 0: NET0 (Single device on an RS232) 1: NET1 (Multiplex mode activated)</p>																											
GMOD	-	Get Mode	<table border="1"> <thead> <tr> <th>MCDC</th> <th>MCBL/ 3564K024B CS</th> <th>Set FAULHABER mode</th> </tr> </thead> <tbody> <tr> <td>D</td> <td>c</td> <td>CONTIMOD</td> </tr> <tr> <td>S</td> <td>s</td> <td>STEPSMOD</td> </tr> <tr> <td>A</td> <td>a</td> <td>APCMOD</td> </tr> <tr> <td>-</td> <td>h</td> <td>ENCMOD</td> </tr> <tr> <td>-</td> <td>e</td> <td>ENCSPEED</td> </tr> <tr> <td>G</td> <td>g</td> <td>GEARMOD</td> </tr> <tr> <td>V</td> <td>v</td> <td>VOLTMOD</td> </tr> <tr> <td>I</td> <td>-</td> <td>IXRMOD</td> </tr> </tbody> </table>	MCDC	MCBL/ 3564K024B CS	Set FAULHABER mode	D	c	CONTIMOD	S	s	STEPSMOD	A	a	APCMOD	-	h	ENCMOD	-	e	ENCSPEED	G	g	GEARMOD	V	v	VOLTMOD	I	-	IXRMOD
MCDC	MCBL/ 3564K024B CS	Set FAULHABER mode																												
D	c	CONTIMOD																												
S	s	STEPSMOD																												
A	a	APCMOD																												
-	h	ENCMOD																												
-	e	ENCSPEED																												
G	g	GEARMOD																												
V	v	VOLTMOD																												
I	-	IXRMOD																												

5 Parameter description

5.2 Query commands for basic setting

Command	Argument	Function	Description
GENCRES	-	Get Encoder Resolution	Set encode resolution (ENCRESES)
GMOTTYP	-	Get Motor Type	Set motor type 0-9 (MOTTYP) -1: DC Motor
GKN	-	Get Speed Constant	Speed constant for MOTTYP0 or DC motor in rpm/V (KN)
GRM	-	Get Motor Resistance	Motor resistance for MOTTYP0 or DC motor in mΩ (RM)
GSTW	-	Get Step Width	Set step width (STW)
GSTN	-	Get Step Number	Set number of steps per revolution (STN)
GMV	-	Get Minimum Velocity	Set minimum velocity in rpm (MV)
GMAV	-	Get minimum analog voltage	Set minimum start voltage value in mV (MAV)
GPL	-	Get Positive Limit	Set positive limit position (LL)
GNL	-	Get Negative Limit	Set negative limit position (LL)
GSP	-	Get Maximum Speed	Set maximum speed in rpm (SP)
GAC	-	Get Acceleration	Set acceleration value in r/s^2 (AC)
GDEC	-	Get Deceleration	Set deceleration value in r/s^2 (DEC)
GSR	-	Get Sampling Rate	Set sampling rate of the speed controller ms/10 (SR)
GPOR	-	Get Velocity Proportional Term	Set amplification value of the speed controller (POR)
GI	-	Get Velocity Integral Term	Set integral term of the speed controller (I)
GPP	-	Get Position Proportional Term	Set amplification value of the position controller (POR)
GPD	-	Get Position D term	Set D component of the position controller (PD)
GCI	-	Get Current Integral Term	Set integral term of the current controller (CI)
GPC	-	Get Peak Current	Set peak current in mA (LPC)
GCC	-	Get Continuous Current	Set continuous current in mA (LCC)
GDEV	-	Get Deviation	Set deviation value (DEV)
GCORRIDOR	-	Get Corridor	Set window around the target position (CORRIDOR)
GNODEADR	-	Get Node Address	Set node number (NODEADR)

5 Parameter description

5.2 Query commands for basic setting

Query commands of predecessor models that are no longer supported for reasons of compatibility:

Command	Argument	Function	Description
GST	-	Get Status	Return current status. 7 ASCII characters "0" and "1" from left to right: Pos. 0: 1: Position controller active 0: Speed controller active Pos. 1: 1: Velocity presetting analog or PWM 0: Velocity presetting via RS232 Pos. 2: 1: Velocity presetting via PWM (Pos. 1 = 1) 0: Velocity presetting analog (Pos. 1 = 1) Pos. 3: 1: Drive is active (enabled) 0: Drive is inactive (disabled) Pos. 4: 1: Target position reached 0: Target position not reached Pos. 5: 1: Positive limit switch edge effective 0: Negative limit switch edge effective Pos. 6: 1: Limit switch at high level 0: Limit switch at low level
GFS	-	Get Fault Status	Return status of the error output. 4 ASCII characters "0" and "1" from left to right: (0=no error, 1=error): Pos. 0: Overtemperature protection Pos. 1: Current limiting controller Pos. 2: Reserved (always 0) Pos. 3: Overvoltage regulator
GAST	-	Get Actual Status	Return current status. 4 ASCII characters "0" and "1" from left to right: Pos. 0: 1: Limit switch 2 at high level 0: Limit switch 2 at low level Pos. 1: 1: Limit switch 3 at high level 0: Limit switch 3 at low level Pos. 2: 1: Clockwise rotation with positive values 0: Anticlockwise rotation with positive values Pos. 3: 1: Homing still active 0: Homing finished

5 Parameter description

5.2 Query commands for basic setting

Command	Argument	Function	Description
GSCS	–	Get Special Configuration Set	<p>Return special settings. 8 ASCII characters "0" and "1" from left to right:</p> <p>Pos. 0: 1: Release homing after power-on 0: Homing blocked after power-on</p> <p>Pos. 1: 1: Fault pin is input 0: Fault pin is output</p> <p>Pos. 2: 1: Pulse output at fault pin (Pos. 1=0) 0: Error signal at fault pin (Pos. 1=0)</p> <p>Pos. 3: 1: Pos. 1 = 1: Fault pin is rotational direction input Pos. 1 = 0: Fault pin is digital output 0: Pos. 1 = 1: Fault pin is limit switch input 2 Pos. 1 = 0: Fault pin is not digital output</p> <p>Pos. 4: 1: Positive edge effective at limit switch 2 0: Negative edge effective at limit switch 2</p> <p>Pos. 5: 1: Positive edge effective at limit switch 3 0: Negative edge effective at limit switch 3</p> <p>Pos. 6: 1: Release drive program 0: Drive program blocked</p> <p>Pos. 7: 1: Release automatic responses 0: No automatic responses</p>
GES	–	Get Enhanced Status	<p>Return enhanced status. 5 ASCII characters "0" and "1" from left to right:</p> <p>Pos. 0: 1: Input no.4 at high level (MDCD) 0: Input no.4 at low level (MDCD)</p> <p>Pos. 1: 1: Input no. 5 at high level (MDCD) 0: Input no. 5 at low level (MDCD)</p> <p>Pos. 2: 1: Analog target current presetting active 0: No analog target current presetting</p> <p>Pos. 3: 1: Position limits active in all modes 0: Position limits inactive</p> <p>Pos. 4: 1: Deviation error exists 0: No deviation errors exist</p>
GAHS	–	Get Actual Homing Status	<p>Current reference switch setting. 5 ASCII characters "0" to "7" from left to right:</p> <p>Pos. 0: HA value Pos. 1: HL value Pos. 2: HN value Pos. 3: HB value Pos. 4: HD value</p>
GHSC	–	Get Homing Sequence Configuration	<p>Setting of homing sequence. 3 ASCII characters "0" to "7" from left to right:</p> <p>Pos. 0: SHA value Pos. 1: SHL value Pos. 2: SHN value</p>

5 Parameter description

5.2 Query commands for basic setting

5.2.2 Configuration of fault pin and digital inputs

Command	Argument	Function	Description
IOC	-	I/O Configuration	Set input/output configuration. Return value binary coded (LSB=Bit 0): Bit 0-7, Hard Blocking: 0-31: Function active for input 1-5 Bit 8-15, Hard Polarity: 0-31: Rising edge at input 1-5 Bit 16-23, Hard Direction: 0-31: Clockwise (1) or counterclockwise (0) movement blocked at Input 1-5 Bit 24, State of digital output: 0: Low 1: High Bit 25, Level of digital inputs: 0: TTL level (5V) 1: PLC LEVEL (24 V) Bit 26-28, Function of fault pin: 0: ERROUT 1: ENCOUT 2: DIGOUT 3: DIRIN 4: REFIN
GDCE	-	Get Delayed Current Error	Set value of the error output delay (DCE)
GPN	-	Get Pulse Number	Set pulse number (LPN)

5.2.3 Configuration of homing

Command	Argument	Function	Description
HOC	-	Homing Configuration	Set homing configuration. Return value binary coded (LSB=Bit 0): Bit 0-7, SHA setting Bit 8-15, SHN setting Bit 16-23, SHL setting Bit 24, Power-On Homing Sequence 0: deactivated 1: activated (homing after power-on)
GHOSP	-	Get Homing Speed	Set homing speed in rpm (HOSP)

5 Parameter description

5.3 Miscellaneous commands

Command	Argument	Function	Description
NE	0 – 1	Notify Error	Error notification: 1: An "r" is sent back if an error occurs 0: No error notification
SAVE EEPSAV		Save Parameters	Save current parameters and configuration setting to Flash memory. The drive will also start with these settings when next switched on. Attention: Command must not be executed more than 10,000 times, as otherwise the function of the Flash memory can no longer be guaranteed.
RESET		Reset	Restart drive node.
RN		Reset Node	Set application parameters to original values (ROM values) (current, acceleration, controller parameters, maximum speed, limit positions...) Communication parameters, operating mode and hardware configuration are retained
FCONFIG		Factory Configuration	All configurations and values are reset to the standard delivery status. After this command the drive performs a reset. Attention: Customer-specific factory settings are also lost, programmed sequence programs are retained! The command can be executed a maximum 10000 times.

5 Parameter description

5.4 Motion control commands

Command	Argument	Function	Description
DI	–	Disable Drive	Deactivate drive
EN	–	Enable Drive	Activate drive
M	–	Initiate Motion	Activate position control and start positioning
LA	Value	Load Absolute Position	Load new absolute target position Value: $-1.8 \cdot 10^9 \dots 1.8 \cdot 10^9$
LR	Value	Load Relative Position	Load new relative target position, in relation to last started target position. The resulting absolute target position must lie between the values given below. Value: $-2.14 \cdot 10^9$ and $2.14 \cdot 10^9$
NP	–/Value	Notify Position	Without argument: A “p” is returned when the target position is attained. With argument: A “p” is returned when the specified position is over-travelled.
NPOFF	–	Notify Position Off	Notify Position command that has not yet been triggered is deactivated again.
V	Value	Select Velocity Mode	Activate velocity mode and set specified value as target velocity (velocity control). Unit: rpm
NV	Value	Notify Velocity	A “v” is returned when the nominal speed is reached or travelled through. Value: $-30\,000 \dots 30\,000$
NVOFF	–	Notify Velocity Off	Velocity command that has not yet been triggered is deactivated again.
U	Value	Set Output Voltage	Output motor voltage (corresponds to $-U_v \dots +U_v$) with SOR0 only Value: $-32\,767 \dots 32\,767$
GOHOSEQ	–	Go Homing Sequence	Execute FAULHABER homing sequence. A homing sequence is executed (if programmed) irrespective of the current mode.
GOHIX	–	Go Hall Index	Move BL motor to Hall zero point (Hall index) and set actual position value to 0 (not with MCDC)
GOIX	–	Go Encoder Index	Move to the encoder index at the Fault pin and set actual position value to 0 (DC motor or ext. encoder).
HO	–/Value	Define Home Position	Without argument: Set actual position to 0. With argument: Set actual position to specified value. Value: $-1.8 \cdot 10^9 \dots +1.8 \cdot 10^9$

5 Parameter description

5.5 General query commands

Command	Argument	Function	Description
GTYP	–	Get Controller Type	Query designation (name) of the controller
GSER	–	Get Serial Number	Query the serial number
VER	–	Get Version	Current software version
POS	–	Get Actual Position	Current actual position
TPOS	–	Get Target Position	Target position
GV	–	Get Velocity	Current target velocity in rpm
GN	–	Get N	Current target velocity in rpm
GU	–	Get PWM Voltage	Set PWM value in VOLTMOD
GRU	–	Get Real PWM Voltage	Current controller output value
GCL	–	Get Current Limit	Current limitation current in mA
GRC	–	Get Real Current	Current actual current in mA
TEM	–	Get Temperature	Current housing temperature in °C
GADV	Value	Get Analog Voltage	Read out the voltage applied at the given input (value). Scaling: 1000 digits = 1 V Return value input 1: -10 000 ... 10 000 Return value input 3, 4, 5: 0 ... 10 000 Value: 1, 3, 4, 5 (4 and 5 for MCDC only)
OST	–	Operation Status	Display current operating status. Return value binary coded (LSB=Bit 0): Bit 0: Homing running Bit 1: Program sequence running Bit 2: Program sequence stopped because of DELAY command Bit 3: Program sequence stopped because of NOTIFY command Bit 4: Current limitation active Bit 5: Deviation error Bit 6: Overvoltage Bit 7: Overtemperature Bit 8: Status input 1 Bit 9: Status input 2 Bit 10: Status input 3 Bit 11: Status input 4 Bit 12: Status input 5 Bit 13 – 15: Reserved for further inputs Bit 16: Position attained
SWS	–	Switch Status	Temporary limit switch settings. Return value binary coded (LSB=Bit 0): Bit 0-7: HA setting Bit 8-15: HN setting Bit 16-23: HL setting Bit 24-31: Details of which limit switch has already switched (is reset again when new setting entered at the respective input)

5 Parameter description

5.6 Commands for sequence programs

Commands for generating and executing sequence programs:

Command	Argument	Function	Description
PROGSEQ [...] END	-	Program Sequence	<p>Defines the start and end of the sequence program.</p> <p>All commands sent to PROGSEQ are not executed, but transferred to the sequence program memory. An END marks the end of the sequence program.</p> <p>All commands after END are directly executed again.</p> <p>There is no SAVE command necessary for saving the program sequence.</p> <p>Command must not be executed more than 10,000 times, as otherwise the function of the Flash memory can no longer be guaranteed.</p> <p>These commands do not have to be entered in the FAULHABER Motion Manager, as they are automatically attached by the "Transfer program file..." function.</p> <p>Note:The Xon/Xoff protocol must be used to transfer lengthy program sequences</p>
GPROGSEQ	-/1	Get Program Sequence	<p>Reads out and sends back the stored program sequence. Each program line is output in lower case letters, ending with a CR character. At the end of the program the line "end:" is sent, with specification of the program length in bytes followed by a CR and LF character.</p> <p>GPROGSEQ1: Reads out the program sequence and indicates at which program line the program counter is currently located ("PC--")</p>
ENPROG	-	Enable Program	<p>Execution of the program is released, i.e. the sequence is started. This status can be permanently stored with SAVE/EEPSAV, so that the drive starts up with the stored program sequence immediately after switch-on.</p>
DIPROG	-	Disable Program	<p>Deactivate program execution.</p>
RESUME	-	Resume	<p>Continue program sequence after DIPROG at the point at which it was interrupted.</p>
MEM	-	Memory	<p>Return available program memory in Word.</p>

5 Parameter description

5.6 Commands for sequence programs

Additional commands for use within sequence programs:

Command	Argument	Function	Description
DELAY	Value	Delay	Stop sequence for a defined time Argument: in 1/100 seconds Value: 0 to 65535
TIMEOUT	Value	Timeout	With Notify commands, only wait for the specified time and then continue the sequence again. Can also be used via RS232: Send an "o" if Notify condition has not been fulfilled. Argument: in 1/100 seconds Value: 0 to 65535
JMP	Adr	Jump	Jump to specified address. (Can also be used via RS232). Address: 0...255
JMPGx	Adr	Jump if greater than x	Jump to the specified address if result of last query command is greater than variable x (A, B, C). Address: 0...255
JMPLx	Adr	Jump if less than x	Jump to the specified address if result of last query command is less than variable x (A, B, C). Address: 0...255
JMPEx	Adr	Jump if equal x	Jump to specified address if result of last query command is equal to variable x (A, B, C). Address: 0...255
JPH	Adr	Jump if Hard-Input activated	Jump to the specified address if the analog input is active (HP determines the polarity). Address: 0...255
JPF	Adr	Jump if Hard-Input activated	Jump to the specified address if the Fault Pin input is active (HP determines the polarity). Fault Pin must be configured as input (REFIN). Address: 0...255
JPT	Adr	Jump if 3. Input activated	Jump to the specified address if the 3rd input is active (HP determines the polarity). Address: 0...255
JPD (only MCDC)	Adr	Jump if 4. Input activated	Jump to the specified address if the 4th input is active (HP determines the polarity). Address: 0...255
JPE (only MCDC)	Adr	Jump if 5. Input activated	Jump to the specified address if the 5th input is active (HP determines the polarity). Address: 0...255
SETx	Value	Set Variable x	Set variable x (A, B, C) to the specified value. Value: Int32 Without argument: Result of last query command is loaded into the variable. Value: - 2147483648 ... + 2147483647
GETx	-	Get Variable x	Query content of variable x (A, B, C).
ADDx	Value	Add to Variable x	Add or subtract variable x (A, B, C) with given value. Value: - 2147483648 ... + 2147483647
SETARGx	-	Set argument	Set value of variable x (A, B, C) as argument for the next command (if no argument is given there).
DxJNZ	Adr	Decrement x, Jump if not Zero	Decrease the value of variable x (A, B, C) by one and jump to specified address if the value is not 0. Address: 0...255
ERI	Adr	Error Interrupt	An error interrupt is activated from execution of this command. This means that if an error subsequently occurs (overvoltage, current limitation...), then the sequence branches to the specified address. The error handling mode is ended if a JMP or RETI command is executed. Address: 0...255
RETI	-	Return Error Interrupt	Return from an error handling routine. Important: the interrupted command is not continued, even if it was not completed at the time of interruption!
DIERI	-	Disable Error Interrupt	The ERI command is deactivated, i.e. in the event of an error the program does not jump to the error handling routine.
CALL	Adr	Call Subroutine	Call a subroutine at specified address. Address: 0...255
RET	-	Return from Subroutine	Return from a subroutine. Please note that only one subroutine level is possible, i.e. no subroutines can be called within subroutines!
A	Adr	Define Address	Definition of current position as entry address for jump commands. Address: 0...255

5 Parameter description

5.7 Configuration at delivery

The standard configuration n parameters with which the units are delivered are listed below. These settings can also be reloaded at any time with the command FCONFIG, followed by a hardware reset.

3564K024B CS:

FAULHABER command	Description
CONTMOD	Normal operation
APLO	Position limits deactivated
SOR0	Velocity presetting via R5232
MOTTYP8	Motor type 3564K024B K1155
ERROUT	Fault pin = error output
HP7	All inputs react to rising edge
HB0, HD0	No Hard Blocking limit switches defined
HOSP100	Homing Speed = 100 rpm
SHA0, SHL0, SHN0	No FAULHABER homing defined
ADR	Analog direction of rotation right
LPC8000	Peak current limitation = 8 A
LCC2800	Continuous current limitation = 2.8 A
AC30000	Acceleration = 30 000 r/s ²
DEC30000	Deceleration ramp = 30 000 r/s ²
SR1	Sampling rate = 100 µs
I40	I-term of velocity controller
POR8	P-term of velocity controller
PP12	P-term of position controller
PD6	D-term of position controller
CI50	I-term of current controller
SP12000	Limitation of maximum speed to 12 000 rpm
MV0	Smallest analog speed
MAV25	Smallest analog voltage
LL1800000000	Upper positioning range limit
LL-1800000000	Lower positioning range limit
LPN16	Numerical value for pulse output
STW1	Step width for special mode
STN1000	Number of steps for special mode
ENCRES2048	Resolution of external encoder
DEV30000	Do not monitor deviation error
DCE200	Error delay 2 sec.
CORRIDOR20	Target corridor for positioning
SIN1	Do not allow block commutation
SETPLC	Digital inputs PLC-compatible
NET0	Multiplex mode is deactivated
BAUD9600	Transfer rate 9 600 baud
NODEADR0	Node number = 0
COMPATIBLE0	Not in compatibility mode
ANSW2	Asynchronous responses activated
POHOSEQ0	No homing sequence after switching on
DIPROG	Sequence programs deactivated
DI	Power output stage deactivated
V0	Target speed value = 0 rpm

5 Parameter description

5.7 Configuration at delivery

MCBL 3003 / 06 S:

FAULHABER command	Description
CONTMOD	Normal operation
APL0	Position limits deactivated
SOR0	Velocity presetting via RS232
MOTTYP5	Motor type 2444S024B K1155
ERROUT	Fault pin = error output
HP7	All inputs react to rising edge
HB0, HD0	No Hard Blocking limit switches defined
HOSP100	Homing Speed = 100 rpm
SHA0, SHL0, SHN0	No FAULHABER homing defined
ADR	Analog direction of rotation right
LPC5000	Peak current limitation = 5 A
LCC1370	Continuous current limitation = 1.37 A
AC30000	Acceleration = 30 000 r/s ²
DEC30000	Deceleration ramp = 30 000 r/s ²
SR1	Sampling rate = 100 µs
I40	I-term of velocity controller
POR7	P-term of velocity controller
PP16	P-term of position controller
PD9	D-term of position controller
CI50	I-term of current controller
SP30000	Limitation of maximum speed to 30 000 rpm
MV0	Smallest analog speed
MAV25	Smallest analog voltage
LL1800000000	Upper positioning range limit
LL-1800000000	Lower positioning range limit
LPN16	Numerical value for pulse output
STW1	Step width for special mode
STN1000	Number of steps for special mode
ENCRES2048	Resolution of external encoder
DEV30000	Do not monitor deviation error
DCE200	Error delay 2 sec.
CORRIDOR20	Target corridor for positioning
SIN1	Do not allow block commutation
SETPLC	Digital inputs PLC-compatible
NET0	Multiplex mode is deactivated
BAUD9600	Transfer rate 9 600 baud
NODEADR0	Node number = 0
COMPATIBLE0	Not in compatibility mode
ANSW2	Asynchronous responses activated
POHOSEQ0	No homing sequence after switching on
DIPROG	Sequence programs deactivated
DI	Power output stage deactivated
V0	Target speed value = 0 rpm

MCDC 3003 / 06 S:

FAULHABER command	Description
CONTMOD	Normal operation
APL0	Position limits deactivated
SOR0	Velocity presetting via RS232
ERROUT	Fault pin = error output
HP31	All inputs react to rising edge
HB0, HD0	No Hard Blocking limit switches defined
HOSP100	Homing Speed = 100 rpm
SHA0, SHL0, SHN0	No FAULHABER homing defined
ADR	Analog direction of rotation right
LPC10000	Peak current limitation = 10 A
LCC5000	Continuous current limitation = 5 A
AC30000	Acceleration = 30 000 r/s ²
DEC30000	Deceleration ramp = 30 000 r/s ²
SR1	Sampling rate = 100 µs
I50	I-term of velocity controller
POR10	P-term of velocity controller
PP10	P-term of position controller
PD5	D-term of position controller
CI40	I-term of current controller
SP30000	Limitation of maximum speed to 30 000 rpm
MV0	Smallest analog speed
MAV25	Smallest analog voltage
LL1800000000	Upper positioning range limit
LL-1800000000	Lower positioning range limit
LPN16	Numerical value for pulse output
STW1	Step width for special mode
STN1000	Number of steps for special mode
ENCRES2048	Resolution of external encoder
DEV30000	Do not monitor deviation error
DCE200	Error delay 2 sec.
CORRIDOR20	Target corridor for positioning
SETPLC	Digital inputs PLC-compatible
NET0	Multiplex mode is deactivated
BAUD9600	Transfer rate 9 600 baud
NODEADR0	Node number = 0
COMPATIBLE0	Not in compatibility mode
ANSW2	Asynchronous responses activated
POHOSEQ0	No homing sequence after switching on
DIPROG	Sequence programs deactivated
RM200000	Motor resistance = 200 Ω
KN14000	Speed constant = 14 000 rpm/V
DI	Power output stage deactivated
V0	Target speed value = 0 rpm

6 Operation

6.1 Commissioning

Before starting up the Motion Controller together with a motor the following points must be checked:

- The Motion Controller has been installed according to the specifications.
- The connection cables on the supply and motor end are connected according to the requirements (risk of polarity reversal!) and are laid so that they cannot be damaged during operation. The maximum load values must be noted and observed. (See Chapter 8 "Technical Data").
- The length of the motor connection cable does not exceed 30 cm or has been laid with appropriate shielding (see chapter 3.5 "Motor wiring").
- Terminals and connectors are protected against ESD.
- The Motion Controller's parameters are suitably configured for the connected motor.
- The power supply unit is designed according to the requirements.

CAUTION!



Power supply

Due to the PWM of the power output stage the motor current is always larger or equal to the current that can be measured at the supply connection U_{mot} . The current information (continuous / peak output current) in the data sheets and the adjustable parameters of the I²t current limiting refer to the motor current and not to the supply current of the Motion Controller!

7 Maintenance

7.1 Service / Maintenance

Motion Controllers are basically maintenance-free. The air filters of cabinet units must be regularly checked and cleaned if required, depending on the quantity of dust.

In the event of heavy soiling, the units themselves must be cleaned with halogen-free agents.

7.2 Troubleshooting

Due to their design the Motion Controllers are trouble-free, if the parameters given in this instruction manual are kept. Should a malfunction occur in spite of this please contact the manufacturer.

Switchboard: +49(0)7031/638-0

E-Mail: info@faulhaber.de

Internet: www.faulhaber.com

8 Technical Data

8.1 Motor 3564K024B CS

8.1.1 Operating data

	3564 K		024 B CS	
Nominal voltage	U _N		24	Volt
Output power	P _{2 max.}		90	W
Efficiency	η _{max.}		80	%
No-load speed	n ₀		10 500	rpm
No-load current	I ₀		0.28	A
Peak torque for 8 A	M _P		160	mNm
Friction torque, static	C ₀		1,10	mNm
Friction torque, dynamic	C _v		2.4 · 10 ⁻⁴	mNm/rpm
Torque constant	k _M		20.0	mNm/A
Current constant	k _I		0.05	A/mNm
Slope of n/M curve	Δn/ΔM		31	rpm/mNm
Mechanical time constant	τ _m		11	ms
Rotor inertia	J		34	gcm ²
Angular acceleration	α _{max.}		109	·10 ³ rad/s ²
Thermal resistance	R _{th 1} /R _{th 2}	2.5/6.3		K/W
Thermal time constant	τ _{w1} /τ _{w2}	23/1 175		s
Operating temperature range		-5 ... +85		°C
Shaft bearings		ball bearings, preloaded		
Shaft load, max.:				
– radial at 3000 rpm (7.4 mm from mounting flange)		108		N
– axial at 3000 rpm (push-on only)		50		N
– axial at standstill (push-on only)		131		N
Shaft play:				
– radial	≡	0.015		mm
– axial	≡	0		mm
Housing material		aluminium, black anodized		
Weight		440		g
Direction of rotation		electronically reversible		
Recommended values - mathematically independent of each other				
Speed range ¹⁾	n _e		5 - 12 000	rpm
Continuous torque up to ²⁾	M _{e max.}		50	mNm
Thermally allowable continuous current ²⁾	I _{e max.}		2.80 ³⁾	A
¹⁾ Power rating of 44 watt at 8 400 rpm and 50 mNm		³⁾ This is a preset value and can be changed over the RS232 interface.		
²⁾ Thermal resistance R _{th 2} by 55 % reduced				

8 Technical Data

8.1 Motor 3564K024B CS

8.1.2 Product dimensions

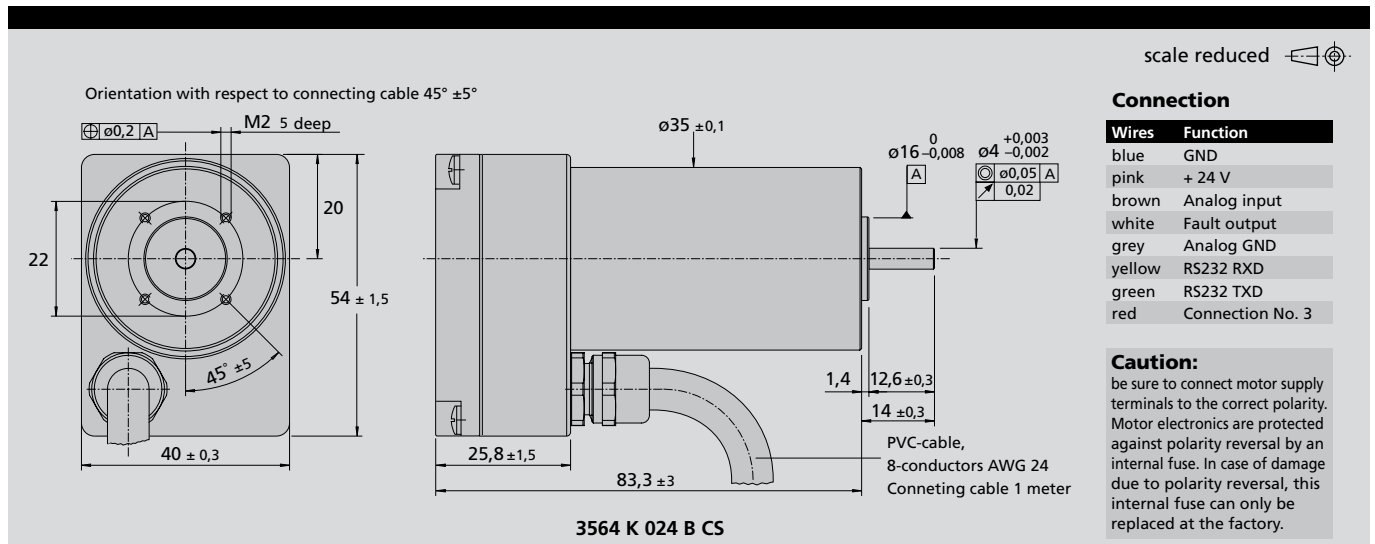

8.1.3 Connection information

Motion Controller				
Supply voltage ¹⁾	U_B		12 ... 30	V DC
Peak current ²⁾	I_{max}		8	A
Input/output (see connection No. 1, 2 and 3)			3	
Connection No. 1 (brown):				
- Speed command analog input		Voltage range	± 10	V
- Speed command PWM input		Frequency range	100 ... 2 000	Hz
- Digital input		Input resistance	5	k Ω
- External encoder	f_{max}		400	kHz
- Step frequency input	f_{max}		400	kHz
Connection No. 2 (white):				
- Fault output		no error	switched to GND	
- Digital output		Open collector	max. $U_B/30$ mA	
- Digital input		Input resistance	100	k Ω
Connection No. 3 (red):				
- Digital input		Input resistance	22	k Ω
- Electronic supply voltage ¹⁾	U_B		12 ... 30	V DC
Encoder:				
- Scanning rate			100	μ s
- Resolution of internal encoder			3 000	Inc./turn

The signal level of the digital inputs can be set using the above commands:
Standard (PLC): Low 0 ... 7 V/High 12.5 V ... U_B , TTL: Low 0 ... 0.5 V/High 3.5 V ... U_B

¹⁾ A separate supply for motor and drive electronic is optional available (important for safety-relevant applications), here escapes the digital input, connection 3 (red).

²⁾ Preset value. Can be changed over the interface.

8 Technical Data

8.2 Motion Controller MCBL 3003 / 06 S

8.2.1 Operating data

		MCBL 3003 S	MCBL 3006 S	
Power supply	U_B	12 ... 30	12 ... 30	V DC
PWM switching frequency	f_{PWM}	78,12	78,12	kHz
Efficiency	η	95	95	%
Max. continuous output current ¹⁾	$I_{continuous}$	3	6	A
Max. peak output current	I_{max}	10	10	A
Total standby current	I_{el}	0.06	0.06	A
Speed range		5 ... 30 000	5 ... 30 000	rpm
Scanning rate	N	100	100	μs
Encoder resolution with Hall sensors		$\leq 3\ 000$	$\leq 3\ 000$	pulses/rev.
Resolution with external encoder		$\leq 65\ 535$	$\leq 65\ 535$	pulses/rev.
Input/output (partially free configurable)		3	3	
Program memory:				
– Memory size		3.3	3.3	kWord
– Number of instructions		approx. 1 000	approx. 1 000	Commands
Operating temperature range		0 ... +70	0 ... +70	°C
Storage temperature		-25 ... +85	-25 ... +85	°C
Housing material		without housing	aluminium, black anodized	
Weight		18	160	g

¹⁾ at 22 °C ambient temperature

8.2.2 Product dimensions

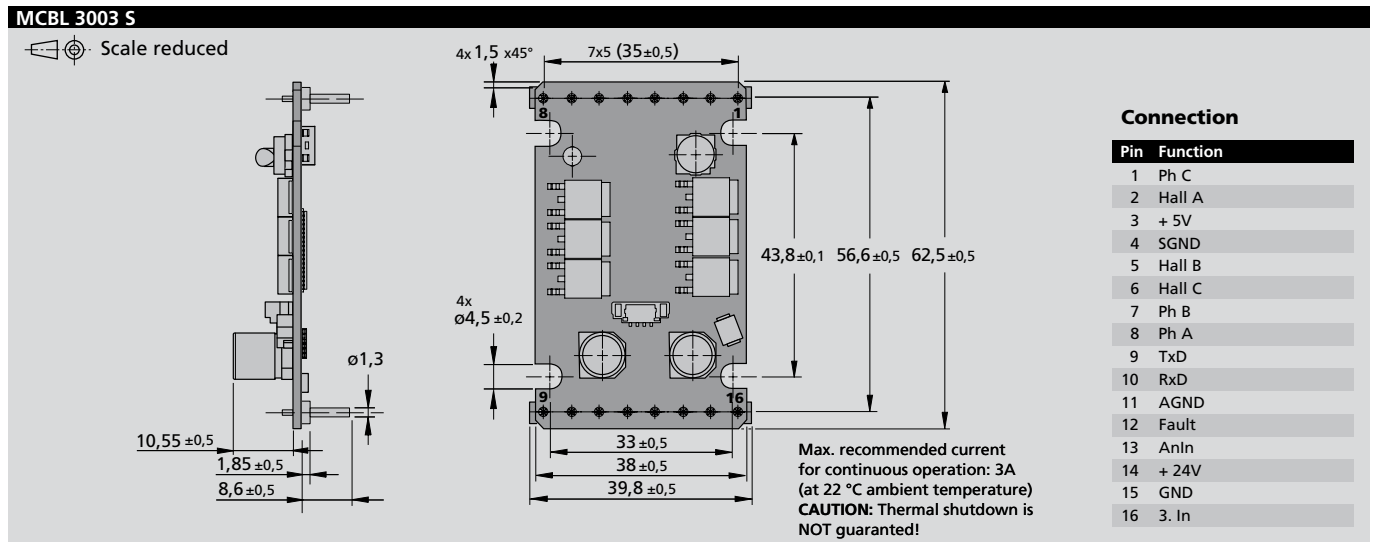

8 Technical Data

8.2 Motion Controller MCBL 3003 / 06 S

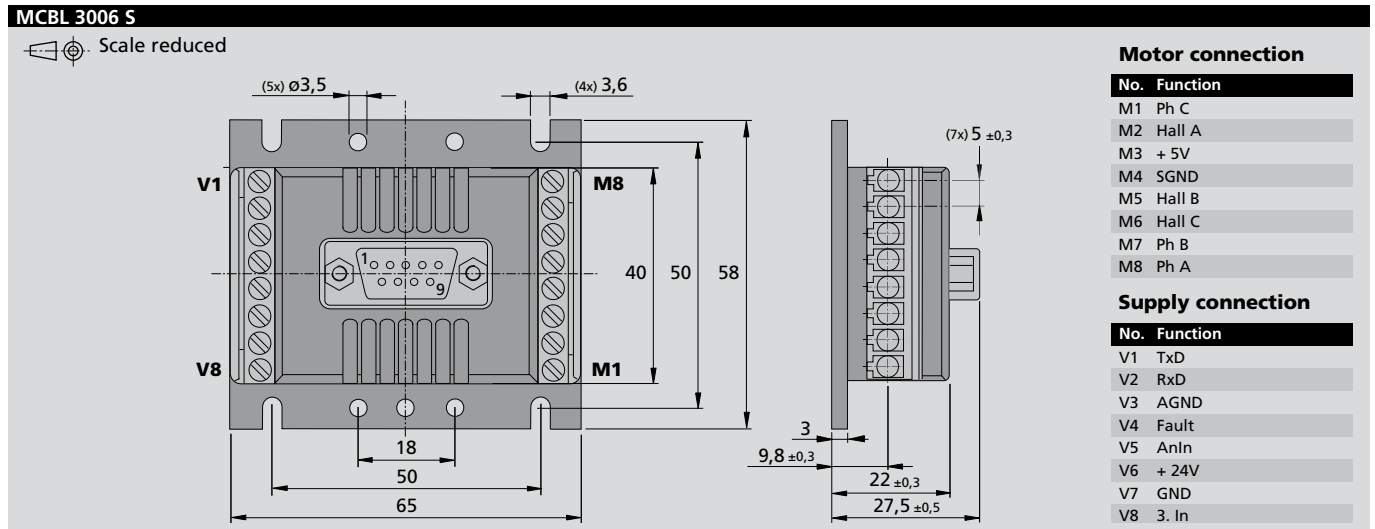

8.2.3 Connection information

Connection "TxD", "RxD":				
Interface			RS232	
Communication profile			Faulhaber - ASCII	
Max. transfer speed rate			115 200	baud
Connection "AGND":				
– analog ground			Analog GND	
– digital input	external encoder		Channel B	
	R_{in}		10	$k\Omega$
	f		≤ 400	kHz
Connection "Fault":				
– digital input		R_{in}	100	$k\Omega$
– digital output (open collector)		U	$\leq U_B$	V
		I	≤ 30	mA
		clear	switched to GND	
		set	high-impedance	
	Fault output	no error	switched to GND	
		Error	high-impedance	
	Signal output	f	≤ 2	kHz
		resolution	1 ... 255	pulses/rev.
Connection "AnIn":			"AGND" as GND	
– analog input	Set speed value	U_{in}	± 10	V
– digital input	PWM set speed value	f	100 ... 2 000	Hz
		T	$50 \% \pm 0 \text{ rpm}$	
	External encoder		Channel A	
		f	≤ 400	kHz
	Step frequency input	f	≤ 400	kHz
		R_{in}	5	$k\Omega$
Connection "+24V":		U_B	12 ... 30	V DC
Connection "GND":			Ground	
Connection "3. In":				
– digital input		R_{in}	22	kHz
– electronic supply voltage ¹⁾		U_B	12 ... 30	V DC

¹⁾ Option on request

8 Technical Data

8.2 Motion Controller MCBL 3003/06 S

Connection "Ph A", "Ph B", "Ph C":				
Motor connection	Ph A		Phase A	brown ¹⁾
	Ph B		Phase B	orange ¹⁾
	Ph C		Phase C	yellow ¹⁾
PWM switching frequency		U _{Out} f _{PWM}	0 ... U _B 78,12	V kHz
Connection "Hall A", "Hall B", "Hall C":				
Hall sensor input	Hall A		Hall sensor A	green ¹⁾
	Hall B		Hall sensor B	blue ¹⁾
	Hall C		Hall sensor C	grey ¹⁾
		U _{In}	≤ 5	V
Connection "SGND":				
Signal GND			Signal ground	black ¹⁾
Connection "+5V":				
Output voltage for external use ²⁾		U _{Out}	5	red ¹⁾ V DC
Load current		I _{Out}	≤ 60	mA

¹⁾ Colour identification for brushless DC Servomotor

²⁾ E.g. Hall sensors

Description of the D-SUB connector

Connection D-sub connector:		
Pin 2	RxD	RS232/RxD
Pin 3	TxD	RS232/TxD
Pin 5	GND	Ground

Digital inputs general information

– PLC, default	high	12.5 ... U _B
	low	0 ... 7
– TTL	high	3.5 ... U _B
	low	0 ... 0.5

The signal level (PLC or TTL) of the digital inputs can be set over the interface.

8 Technical Data

8.3 Motion Controller MCDC 3003 / 06 S

8.3.1 Operating data

		MCDC 3003 S	MCDC 3006 S	
Power supply	U_B	12 ... 30	12 ... 30	V DC
PWM switching frequency	f_{PWM}	78.12	78.12	kHz
Efficiency	η	95	95	%
Max. continuous output current ¹⁾	$I_{continuous}$	3	6	A
Max. peak output current	I_{max}	10	10	A
Total standby current	I_{el}	0.06	0.06	A
Speed range		5 ... 30 000	5 ... 30 000	rpm
Scanning rate	N	100	100	μs
External encoder resolution		$\leq 65\,535$	$\leq 65\,535$	pulses/rev.
Input/output (partially freely configurable)		5	5	
Program memory:				
– Memory size		3.3	3.3	kWord
– Number of instructions		approx. 1 000	approx. 1 000	instructions
Operating temperature range		0 ... +70	0 ... +70	°C
Storage temperature		-25 ... +85	-25 ... +85	°C
Housing material		without housing	aluminium, black anodized	
Weight		18	160	g

¹⁾ at 22 °C ambient temperature

8.3.2 Product dimensions

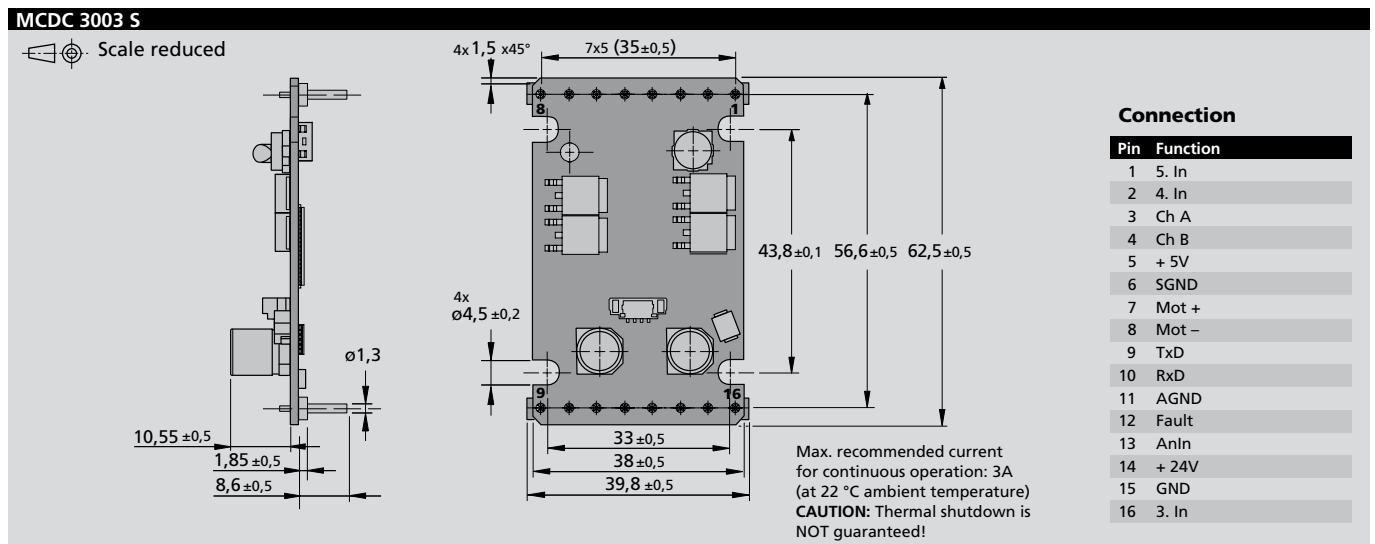

8 Technical Data

8.3 Motion Controller MCDC 3003 / 06 S

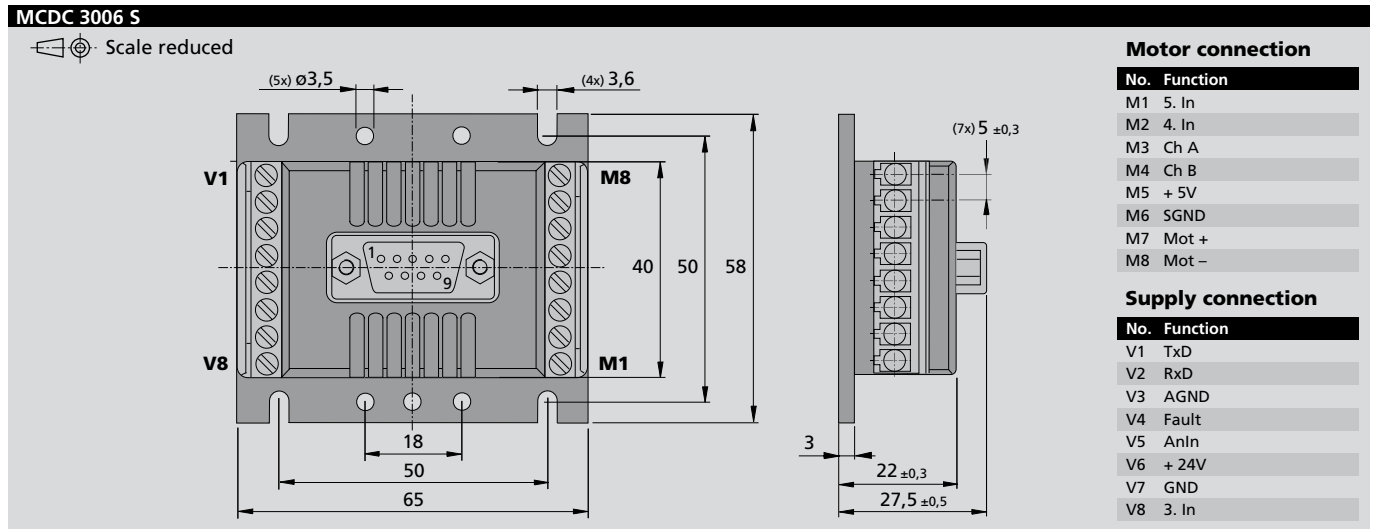

8.3.3 Connection information

Connection "TxD", "RxD":			
Interface			RS232
Communication profile			Faulhaber - ASCII
Max. transfer speed rate			115 200 baud
Connection "AGND":			
- analog ground			Analog GND
- digital input external encoder			Channel B
	R_{in}	10	k Ω
	f	≤ 400	kHz
Connection "Fault":			
- digital input		R_{in}	100 k Ω
- digital output (open collector)		U	$\leq U_B$ V
	I	≤ 30	mA
	clear		switched to GND
	set		high-impedance
Error output		no error	switched to GND
	error		high-impedance
Connection "AnIn":			"AGND" as GND
- analog input	set speed value	U_{in}	± 10 V
- digital input	PWM set speed value	f	100 ... 2 000 Hz
	external encoder	T	50 % \pm 0 rpm
	step frequency input	f	≤ 400 kHz
		f	≤ 400 kHz
		R_{in}	5 k Ω
Connection "+24V":		U_B	12 ... 30 V DC
Connection "GND":			Ground
Connection "3. In":			
- digital input		R_{in}	22 k Ω
- electronic supply voltage ¹⁾		U_B	12 ... 30 V DC
Connection "4. In":			
- digital input		R_{in}	22 k Ω
Connection "5. In":			
- digital input		R_{in}	22 k Ω

¹⁾ Optional on request

8 Technical Data

8.3 Motion Controller MCDC 3003 / 06 S

Connection "Mot -", "Mot +":			
Motor connection	Mot - Mot +		Motor - Motor +
PWM switching frequency		U_{out} f_{PWM}	$0 \dots U_B$ 78.12
			V kHz
Connection "Ch A", "Ch B":			
Encoder input	Ch A Ch B		Encoder channel A Encoder channel B
Integrated pull-up resistance after +5V		R f	2.2 ≤ 400
			k Ω kHz
Connection "SGND":			
Signal GND			Signal ground
Connection "+5V":			
Output voltage for external use ¹⁾		U_{out}	5
Load current		I_{out}	≤ 60
			V DC mA

¹⁾ E.g. Encoder

Description of the D-SUB connector			
Connection D-sub connector:			
Pin 2	RxD		RS232/RxD
Pin 3	TxD		RS232/TxD
Pin 5	GND		Ground

Digital inputs general information			
– PLC, Standard	high		$12.5 \dots U_B$
	low		$0 \dots 7$
– TTL	high		$3.5 \dots U_B$
	low		$0 \dots 0.5$

The signal level (PLC or TTL) of the digital inputs can be set over the interface.

9 EMC

9.1 EC Directives

REGULATION



The following EC Directives are important for users of the described products:

Machinery Directive (98/37/EC):

It applies to independently functioning machines or a chain of machines forming whole plants or systems. For built in components, non-operational machines, a manufacturer's declaration is submitted according to Annex II B of the Machinery Directive 98/37/EC.

Low-Voltage Directive (2006/95/EC):

It applies to all electrical equipment with a nominal voltage from 75 to 1 500 V DC, or from 50 to 1 000 V AC. The products described in this instruction manual do not fall within the scope of this Directive as they are designed for smaller voltages.

EMC Directive (2004/108/EC):

The Electromagnetic Compatibility (EMC) Directive applies to all electronic and electrical equipment, plant and systems sold to end users (consumers). In addition, CE marking can be undertaken for built-in components according to the EMC Directive. Compliance is documented by the Declaration of Conformity.

9 EMC

9.2 Electromagnetic compatibility (EMC)

The facts described here and the listed standards solely refer to products with CE marking, which are listed in the short version of the declaration of conformity.

Electromagnetic compatibility (EMC) is defined as the ability of a device, unit of equipment or system to function satisfactorily in its electromagnetic environment without introducing intolerable electromagnetic disturbances to anything in that environment.

This is necessary to enable simultaneous operation of several units!

Article 5 and Annex 1 of the EMC Directive 2004/108/EC describe the basic requirements for equipment.

Basic requirements

Equipment must be designed and produced according to the recognised rules of sound engineering practice so that

- the electromagnetic faults caused by them do not reach a level at which radio and telecommunication devices or other equipment cannot be operated as intended;
- they are adequately insensitive to the electromagnetic faults to be expected under intended use to enable them to function as intended without unreasonable impairment.

The Directive does not state how high the disturbance level generated by a unit may be and how high the expected disturbances are at which the unit must function. It merely helps by postulating a supposed effect. This falls back on so-called harmonised standards in which the state of the art is defined.

Supposed effect

If equipment conforms to the relevant harmonised standards it is refutably supposed that the equipment conforms to the basic requirements covered by these standards. This supposition of conformity is limited to the scope of the applied harmonised standards and only applies within the scope of the basic requirements covered by these harmonised standards [Directive 2004/108/EC, Article 6, Section 2].

Therefore, different harmonised EMC standards can be used, depending on the use a product is intended for (intended use).

9 EMC

9.2 Electromagnetic compatibility (EMC)

Conformity has been verified by proving compliance with the following harmonised standards:

- EN 61000-6-4: Generic standards – Emission standard for industrial environments
- EN 61000-6-2: Generic standards – Immunity for industrial environments

The aforesaid Generic Standards prescribe certain standardised tests for the emitted-interference and interference-immunity tests. Due to the connections on the Motion Controller the following tests are required:

Generic Standard on Emitted Interference:

- EN 55011, Class A: Radiated emission

Radio disturbance characteristics:

- EN 61000-4-2: Electrostatic discharge ("ESD")
- EN 61000-4-3: Conducted el.-magnet. HF fields
- EN 61000-4-4: Burst
- EN 61000-4-5: Surge
- EN 61000-4-6: Conducted el.-magnet. HF field
- EN 61000-4-8: Magnetic field with power frequency

All tests have been performed and passed; however, additional EMC measures were necessary in several cases.

9 EMC

9.3 EC Declaration of Conformity

The manufacturer: **Dr. Fritz Faulhaber GmbH & Co. KG**

herewith declares that the following product

Product name: **Faulhaber Motion Controller**

Product type: **MCBL 3006 S
MCDC 3006 S**

conforms to the essential safety requirements specified in the following Directive(s):

EMC Directive 2004/108/EC

Conformity is declared with reference to the following applied harmonised standards:

- EN 61000-6-4: Generic standards – Emission standard for industrial environments
- EN 61000-6-2: Generic standards – Immunity for industrial environments

NOTE



Further information

The complete declaration of conformity is available on the internet, please visit www.faulhaber.com.

10 Manufacturer's Declaration

Manufacturer's Declaration according to the Machinery Directive 98/37/EC, Annex II B

The manufacturer: **Dr. Fritz Faulhaber GmbH & Co. KG**
Daimlerstr. 23/25
D-71101 Schönaich
Germany

herewith declares that the products named in the following are built in components and therefore, in the definition of Article 4 (2) of the Directive of the European Parliament and the Council dated 22 June 1998 on the harmonisation of the legal regulations of Member States for Machinery 98/37/EC – in short: the Machinery Directive – are not themselves functioning machines, and for this reason do not yet comply with all parts of the relevant provisions of the Machinery Directive.

Product name: Micro drives, DC micro motors, step motors, motion control systems, precision gears, servo components, controls, micro-precision systems, linear DC servomotors, piezometric motors

Brand names: FAULHABER, PRECIstep, FTB, penny-motor, smoovy, FAULHABER BX4, FAULHABER motion control, Quickshaft, Smartshell, PiezoMotor

It is prohibited to start up the motor until it has been established that the machine in which these components are to be installed is fully functional and conforms to the safety requirements of the Machinery Directive.

Schoenaich, 2008-02-04
(Place, Date)

Dr. Thomas Bertolini,
Executive Management

Signature

11 Warranty

Extract from our warranty conditions

Dr. Fritz Faulhaber GmbH & Co. KG products are produced to state of the art production methods and are subject to strict quality control.

Should, contrary to all expectations, defects occur, we undertake to find a remedy within the warranty period.

- We shall make good or replace defective goods, at our own discretion, within a reasonable period set by you and at our own cost. Replaced goods become our property and are to be returned to us.
- If improvement or replacement delivery is not possible or does not occur or fails for other reasons for which we are responsible within a period determined by you, you can opt to withdraw from the contract for the defective delivery or reduce the purchase price.
- We are not liable for damage to the goods caused by natural wear and tear, wear, unsuitable, improper or non-contractual use, incorrect assembly, installation or putting into service, excessive loading or improper change, improvement or repair work by you or third parties or incorrect or negligent treatment, provided these are not through our fault.
- Further claims, in particular claims for compensation instead of the performance and for compensation of other direct or indirect losses – including accompanying or consequential loss, for whatever legal reason – are excluded. This does not apply if
 - a) we are maliciously silent with regard to a legal or material defect or have issued a guarantee for the nature of the goods,
 - b) the loss is due to deliberate intent or gross negligence by us, our legal representatives or vicarious agents or are based on negligent breach of fundamental contract obligations by these persons, or
 - c) culpable violation of duty by us, our legal representatives or vicarious agents which have resulted in physical injuries or damage to health.

In the case of simple negligence, however, our obligation to pay damages is limited to the amount of typical, foreseeable losses for the type of contract.

- All defect claims including the claims for compensation covered by our terms and conditions of supply expire one year after delivery of the goods to your. The limitation period for replacements and improvements is 1 year but it expires at least when the original limitation period for the delivered object expires. The period for defects liability for a supplied object will be extended by the duration of the operational interruption caused by the making good work. Provisions concerning a shorter life of the object supplied within the scope of its intended use remain unaffected by this limitation provision.

For further information, please refer to our terms and conditions of supply, which we will pleased to make available on request.

12 Command overview

List of commands occurring in this instruction manual

Commands						
A	AC	ADL	ADR	ANSW	APCMOD	APL
BAUD	BINSEND					
CALL	CI	CO	COMPATIBLE	CONTMOD	CORRIDOR	CST
DCE	DEC	DELAY	DEV	DI	DIERI	DIGOUT
DIPROG	DIRIN	DxJNZ				
EEPSAV	EN	ENCMOD	ENCOUT	ENCRES	ENCSPPEED	END
ENPROG	ERI	ERROUT				
GAC	GADV	GAHS	GAST	GCC	GCI	GCL
GCORRIDOR	GDCE	GDEC	GDEV	GEARMOD	GENCRES	GES
GETx	GFS	GHOSP	GHSC	GI	GKN	GMAV
GMOD	GMOTTYP	GMV	GN	GNL	GNODEADR	GOHIX
GOHOSEQ	GOIX	GPC	GPD	GPL	GPN	GPOR
GPP	GPROGSEQ	GRC	GRM	GRU	GSCS	GSER
GSP	GSR	GST	GSTN	GSTW	GTYP	GU
GV						
HA	HALLSPEED	HB	HD	HL	HN	HO
HOC	HOSP	HP				
I	IOC	IXRMOD				
JMP	JMPEx	JMPGx	JMPLx	JPD	JPE	JPF
JPH	JPT					
KN						
LA	LCC	LL	LPC	LPN	LR	
M	MAV	MEM	MOTTYP	MV		
NE	NET	NODEADR	NP	NPOFF	NV	NVOFF
OST						
PD	POHOSEQ	POR	POS	PP	PROGSEQ	
REFIN	RESET	RESUME	RET	RETI	RM	RN
SAVE	SETPLC	SETTTL	SETx	SHA	SHL	SHN
SIN	SO	SOR	SP	SR	STEPMOD	STN
STW	SWS					
TEM	TIMEOUT	TO	TPOS			
U						
V	VER	VOLTMOD				

Notes

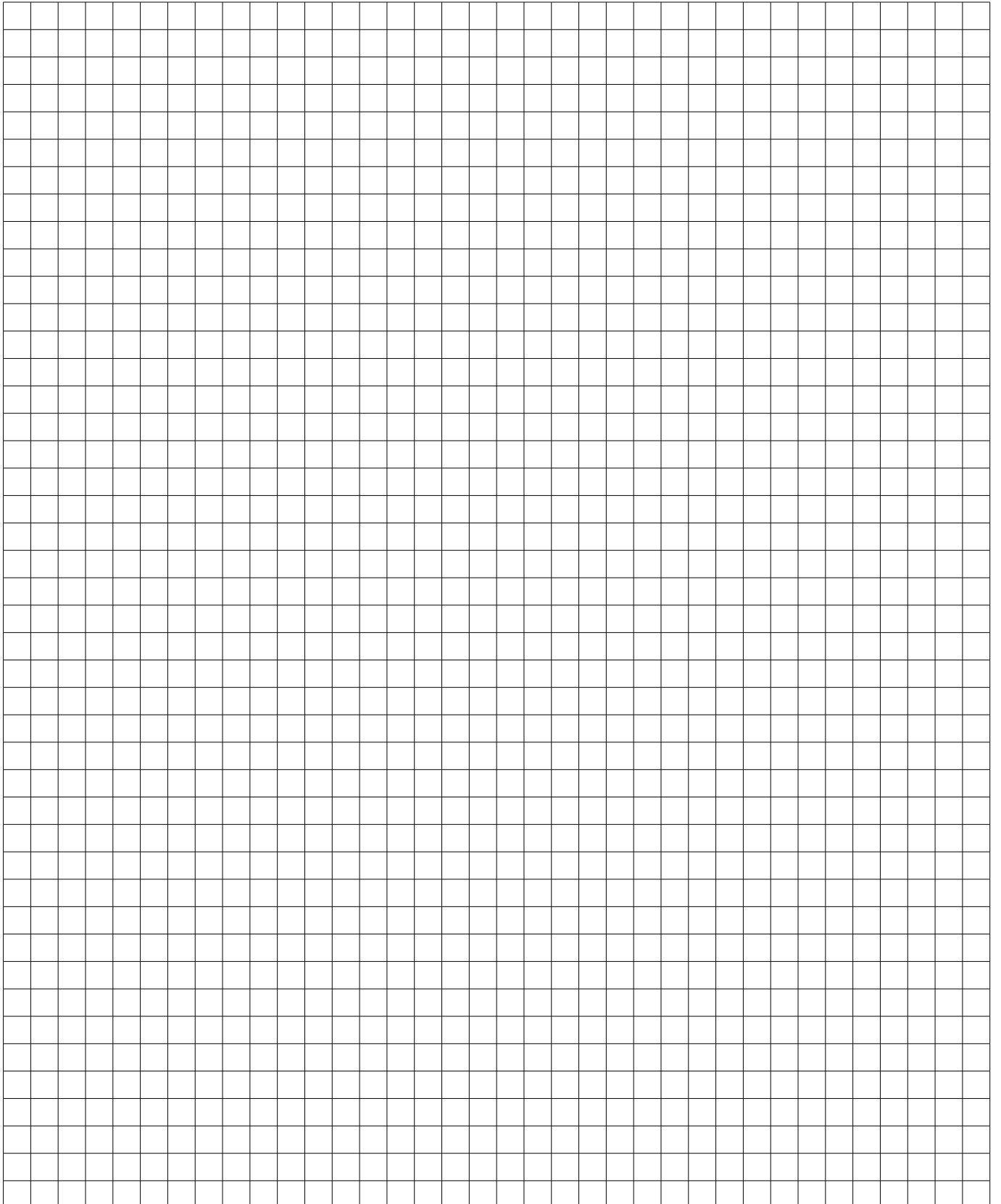

Notes

