

Servo Amplifier

4-Quadrant PWM for Brushless DC-Servomotors

Series BLD 7010



Miniature Drive Systems

Micro Drives
 DC-Micromotors
 Precision Gearheads
 Servo Components
 Drive Electronics

Surf to the following Internet address and you will find the latest edition of the instruction manual on-line :

www.minimotor.ch/uk/pr/

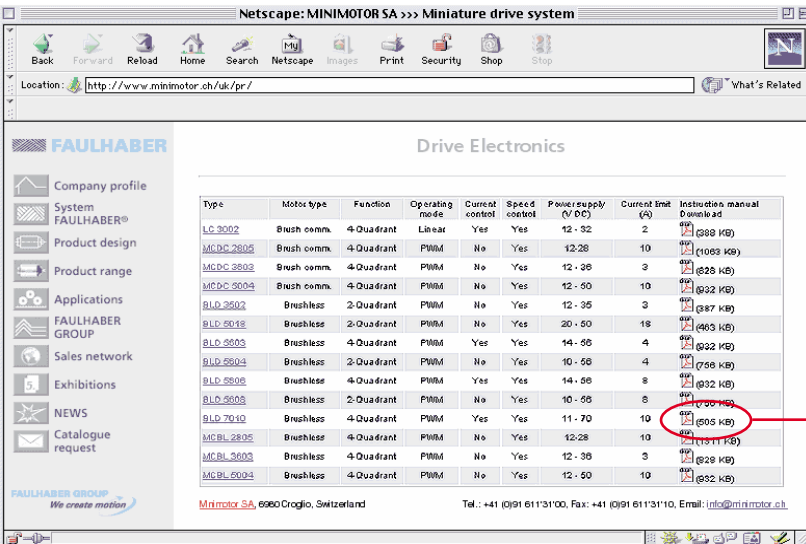

For direct Download:

http://www.minimotor.ch/minicatalog/pdf/DriveCircuits/Manuals/IM_e_BLD_7010.pdf

Index

Chapter	page
1. Description	2
2. Illustration	2
3. Specification	3
4. Dimensions	3
5. Safety notes	4
5.1 Skilled personnel	4
5.2 Laws	4
5.3 Remove load	4
5.4 Additional safety components	4
5.5 Repair	4
5.6 Danger	4
5.7 Maximum input voltage	4
5.8 ESD	4
5.9 EMC	4
6. Preparing	5
6.1 Operating mode	5
6.2 Connecting diagrams	5
6.3. Input for set value	6
6.4. Timing	6
6.5. Phasing	6
6.6. Speed range	6
7. Commission	7
7.1. Selection of power supply	7
7.2. Function of potentiometers	7
7.3. Presetting of potentiometers	7
7.4. Adjustment	7
7.5. Commissioning	8
8. Description of function of inputs and outputs	9
8.1. Inputs	9
8.2. Outputs	11
9. Troubleshooting	13

General information

1. Description

The Servo Amplifier BLD 7010 is a powerful PWM-module for brushless DC-Servomotors with an output range up to 700 Watt.

Three operation modes are integrated

- Torque-control
- Speed-control by digital-encoder feedback
- Speed-control by Hall sensors

The required operation mode is to be selected from the front side of the module by setting jumpers. This BLD 7010 servo amplifier is protected against over current, overheat and short-circuit of the output stage against each other or to the power supply. By the usage of advanced technology and power- MOSFETs a high efficiency up to 95 %. Due to the wide range of power supply voltage between 11 to 70 VDC the BLD 7010 can be used very flexible with different kinds of power supplies within many applications.

The robust aluminum case has been constructed for different methods of mounting it, therefor a fast integration is. Screw terminals and a durable controller-design allow a fast and straightforward commissioning.

2. Illustration



Figure 1

Specification & dimensions

3. Specification	BLD 7010 SC4P	
Power supply	11 ÷ 70	V DC
Switching frequency	49	kHz
Continuous output current @ TA = 22°C	10	A
Peak current limit	20	A
Analog input command: ¹⁾		
– Voltage range	± 10	V DC
Logic input:		
– Encoder	TTL level A, B channel	
– Encoder frequency	100	kHz
– Enable	8 - 30	V DC
Output voltage for external use:		
– Positive (max. 20 mA)	+ 15	V DC
– Positive (max. 100 mA)	+ 5	V DC
– Negative (max. 20 mA)	- 15	V DC
Maximum controllable speed with Hall Sensor ²⁾	5 000 / 40 000	rpm
Minimum controllable speed with Hall Sensor ³⁾	250 / 2 000	rpm
Maximum controllable speed with Encoder (with 1 000 lines per revolution) ²⁾	1 250 / 10 000	rpm
Minimum controllable speed with Encoder ³⁾	5 / 40	rpm
External inductance ⁴⁾	100 ÷ 300	µH
Temperature range:		
– Operating temperature	-10 ... + 45	°C
– Storage temperature	-40 ... + 80	°C

¹⁾ Analog input command may be set by an external potentiometer or an external voltage.

²⁾ The maximum controllable speed depends on the power supply, the motor type, the load and the feedback.

³⁾ The minimum controllable speed depends on the motor type, the load and the feedback.

⁴⁾ The appropriate value depends on the operating cycle and working conditions.

4. Dimensions and weight

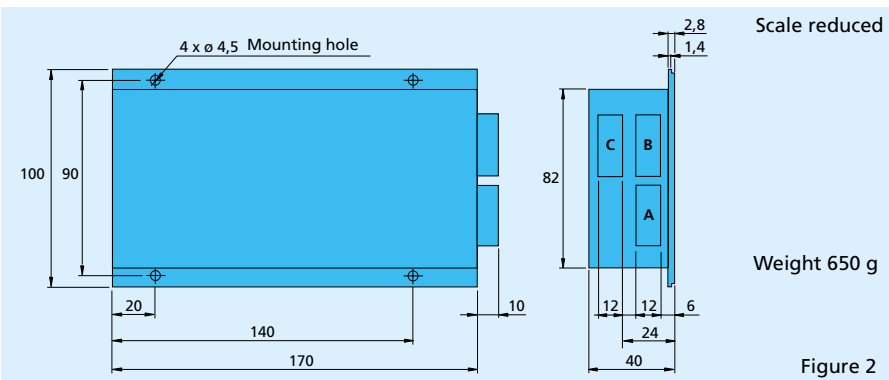

Safety notes

5. Safety notes

5.1 Skilled personnel

Installation and commissioning have to be done only by skilled personnel.

5.2 Laws

The user has to ensure the correct installation of the servo amplifier and additional equipment according to valid laws and rules.

5.3 Remove load

For first commissioning the motor should run with free shaft which means without load.

5.4 Additional safety components

Electronic components are not free of failure or damage. Therefore plants have to be installed with additional device and installation protecting components. A safe and stable state has to be ensured in the case of damage of some devices, wrong handling, cable disruption and other cases of any kind of malfunction.

5.5 Repair

Repairs have to be done only by authorized distributors or at the manufacturer. Unauthorized opening and improper repairs of the device may cause danger to the user and the plant.

5.6 Danger

Care about having no power supply voltage all around the plant during installation of the device. Never touch any voltage-carrying components.

5.7 Maximum input voltage

The input power supply voltage must not exceed 70 VDC. Voltages exceeding 70 V or reversed connection will destroy the unit.

5.8 ESD

Do not touch any of the contacts of the device.

5.9 EMC

The BLD 7010 corresponds to the EC directives, standards and regulations 89/336/EEG article 10 and appendix 1 (EMV) amended by 92/31/EEG and 93/68/EEG and meet the requirements with standard EN 61800-3 (1996) if the following directions are observed:

- usage of a zinc plated mounting plate, well connected to earth
- mounting of the drive by usage of toothed washers
- usage of shielded cables to and from the unit
- large area contact of the shielding with zinc plated mounting plate.
- motor housing properly connected to earth

Preparing

6. Preparing

Required selection of:

- operating mode
- input for set value
- timing
- phasing
- speed range

6.1 Operating mode

Operating mode	Jumper setting	Active potentiometers	Minimal connection of control inputs
Torque control	4	Gain, $n_{max.}$, $I_{max.}$.Offset	6; 9 - 13; 17; 18
Hall	7; 8; 9	Gain, $n_{max.}$, $I_{max.}$.Offset	6; 9 - 13; 17; 18
Encoder	5; 6; 7	$I_{max.}$.Offset	6 - 13; 17; 18

6.2 Connecting diagrams

Block diagram of the Servo Amplifier BLD 7010 for speed control with Hall sensor feedback or torque control

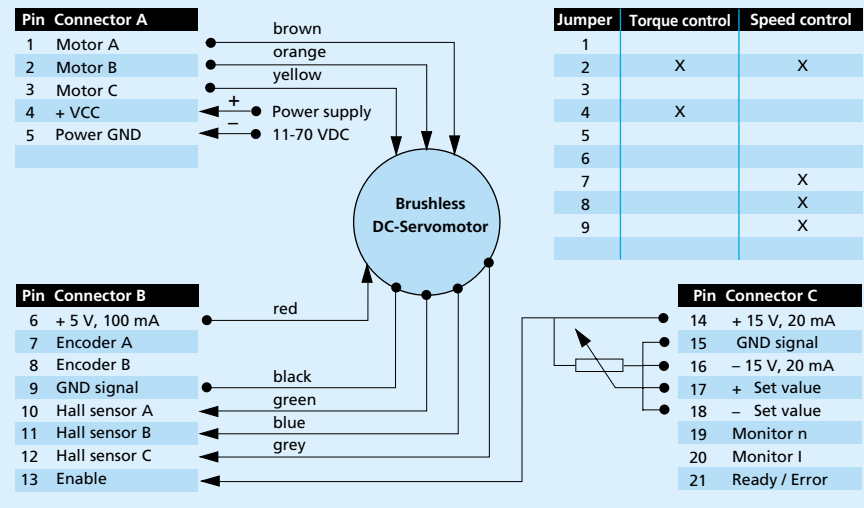

Preparing

Block diagram of the Servo Amplifier BLD 7010 for speed control with Encoder feedback

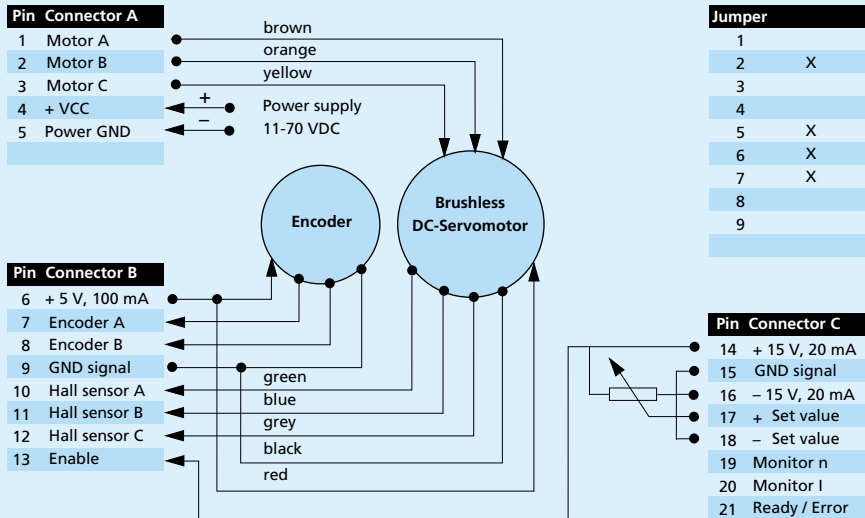

6.3. Input for set value

at use of external potentiometer (min. 10 k Ω) for set value the wiper has to be connected to **pin 17**, the others to **pins 14** and **16**. **Pin 15** and **18** have to be connected and **J3** is to be removed. at use of the internal set value via offset potentiometer **pin 15** and **18** are left without connection and **J3** is to be set.

6.4. Timing

jumper **J2** sets the timing of the hall sensor logic to reach an adaptation to several motor types. The setting belongs to the direction of the phases. **J2** changes the rotation sense of the electrical field. For the brushless DC- Servomotors 4490 **J2** must to be set.

6.5. Phasing

jumper **J1** is for setting the phase shift of the signals of the Hall sensors. The correct value is to provide by the manufacturer of the motor (see datasheet of motor). For 4490 motors **J1** must be removed.

6.6. Speed range

the speed range is to be set by jumper **J10** and **J11**. One of four speed ranges is to be set. The best result of speed control can be reached by setting the lowest acceptable range because of the resolution.

Commission

7. Commission

7.1. Selection of power supply.

Any power supply can be used as long the minimal requirements listed below are fulfilled. We recommend to remove the motor from the mechanical construction to avoid damage and danger by uncontrolled movements of

Requirements to the power supply:

output voltage: min. 11 VDC max. 70 VDC
 residual voltage: < 5 %
 output current: 10 A nominal, 20 A peak

7.2. Function of potentiometers

Potentiometer	Function	Turning CCW	Turning CW
Gain coarse	gain adjustment	decreasing	increasing
Gain fine	gain adjustment	decreasing	increasing
n_{max.}	maximum speed at set value of 10V	decreasing speed	increasing speed
I_{max.}	current limitation	decreasing min. 0,3 A	increasing max. 10 A
Offset	adjustment n = 0 at set value = 0	motor turns CW	motor turns CCW

7.3. Presetting of potentiometers

Original delivered servo amplifiers are adjusted to uncritical values and for easy adjustment by the user.

7.4. Adjustment

Hall control
Digital-Encoder-
regelung

1. adjust max. set value (e.g. 10 V) and turn potentiometer **n_{max.}** CW til the required speed is reached.
2. adjust potentiometer **I_{max.}** to required value of current limitation.
Important: Refer to motor manufacturer's data sheet.
3. turn potentiometer **Gain** slowly CW until the required gain is reached.
Important: If the motor turns rough, is vibrating or makes noise turn potentiometer CCW again, until the instability of the system is obsolete. The potentiometers **Gain coarse** and **Gain fine** work in an additive way.
4. adjust set value = 0V and adjust potentiometer **Offset** until the motor stops to speed 0.

Torque control

1. adjust potentiometer **I_{max.}** to required value of current limitation.
Important: Refer to motor manufacturer's data sheet.

Commission

7.5. Commissioning

select the required operating mode by setting the according jumpers on the left side of the unit. Refer to the printing on the front plate.

Required selection of:

- operating mode
- input for set value
- timing
- phasing
- speed range

Connect motor, control inputs e.g. set value, enable and if necessary an additional encoder to the drive. Connect power supply. enabling and adjustment referring to manual.

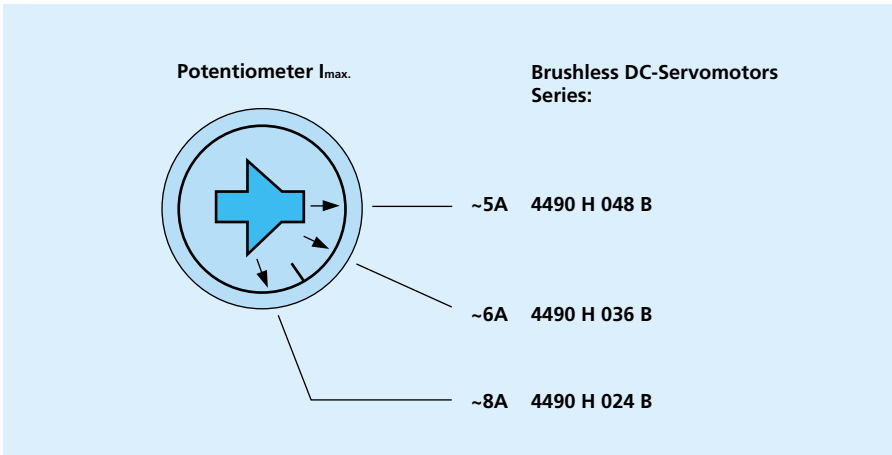

Description of function of inputs and outputs

8. Description of function of inputs and outputs

In () the pin number

8.1. Inputs

8.1.1 Set value (17, 18)

the input for set value is internally connected to an differential amplifier.

input range of set value: $-10\text{ V} \dots +10\text{ V}$

input impedance: $20\text{ k}\Omega$

definition of polarity: positive set value (+Set value) > (- Set value)
negative set value(+Set value) < (- Set value)

Input circuit set value:

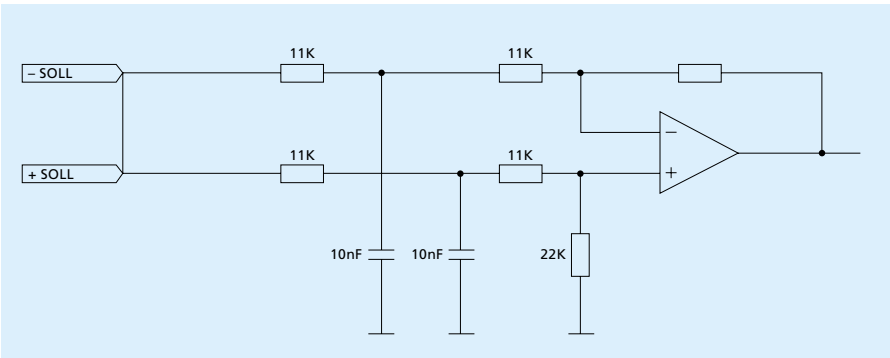

8.1.2 Enable (13)

high potential at the input enable will activate speed/torque control and voltage will be applied to the motor winding. Leaving this input without connection or pulling it to GND-potential will result in disabling the unit.

Input circuit enable:

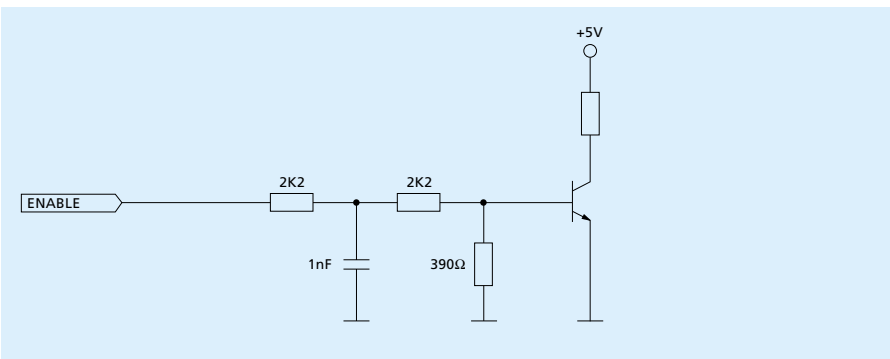

Description of function of inputs and outputs

8.1.3. Encoder A (7)

8.1.4. Encoder B (8)

the inputs encoder A, B are to be connected to the corresponding outputs of the encoder in operating mode speed control with encoder feedback.

Input circuit encoder:

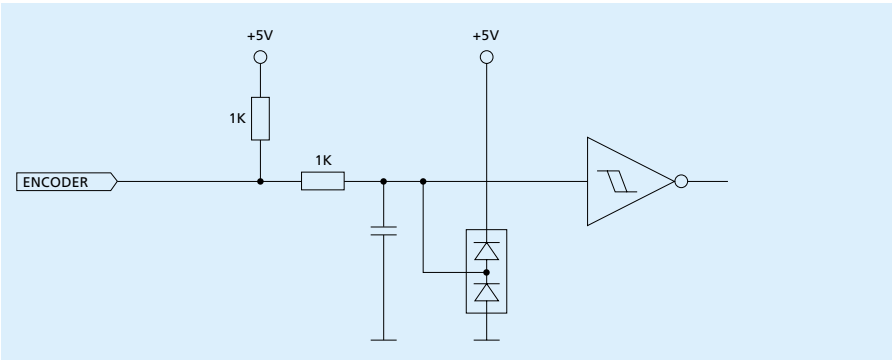

8.1.5. Hall A (10)

8.1.6. Hall B (11)

8.1.7. Hall C (12)

Inputs for the Hall effective sensors of the motor. The correct connection regarding phase sequence and phase relation is essential

Input circuit hall effective sensors:

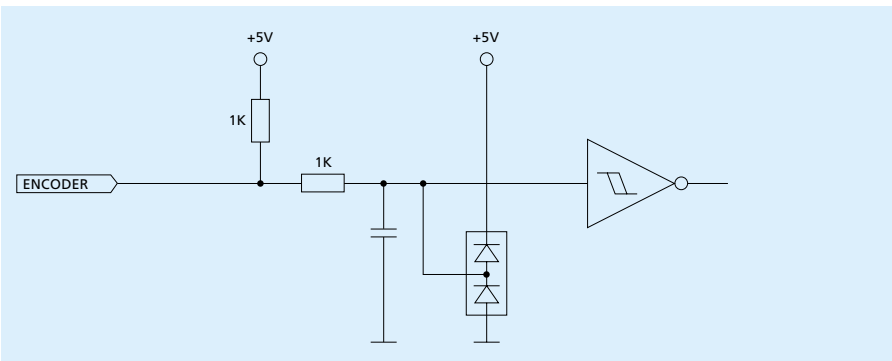

8.1.8. Power gnd (5)

8.1.9. +Vcc (4)

power supply connection.

Caution: do not connect: +Vcc or Power GND to the outputs Motor A, B, or C

Description of function of inputs and outputs

8.2. Outputs

8.2.1. Current monitor Monitor I (19)

a current monitor for supervisory purposes is integrated to the servo amplifier. The output provides an analog signal (voltage) which is proportional to the motor current. the monitor output is short circuit proof.

Output range: -10 V... +10 V
 Output impedance: 10 k Ω
 Output proportionality: 0,5V/A
 Output circuit current monitor:

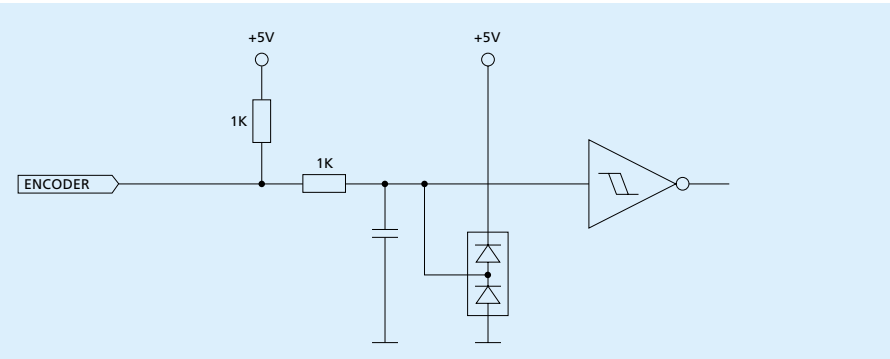

8.2.2. Speed monitor Monitor n (20)

a speed monitor for supervisory purposes is integrated to the servo amplifier. The output provides an analog signal (voltage) which is proportional to the motor speed. It can be used for qualitative weighting of the dynamic of the drive system.

Output range: -10 V... +10 V
 Output impedance: 10 k Ω
 Output proportionality: 10V at maximum speed
 Output circuit speed monitor:

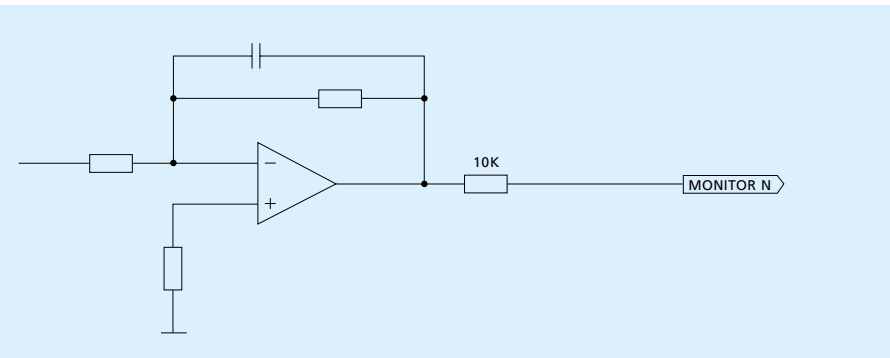

Description of function of inputs and outputs

8.2.3. Supervision signal Ready / Error (21)

The ready-signal is to show the status of the drive and can be used to provide a feedback signal to other devices and controls. The open-collector output is normally turned off which means the output is pulled to a positive level by an external connected resistor, if there is no fault within the drive system.

In the case of a fault like under voltage, overvoltage, overheat or overcurrent the internal transistor is on, the output is pulled to GND.

Input range max. 30 VDC

load current < 20 mA

any fault is stored and can be reset by enable off and on.

Output circuit ready/error signal:

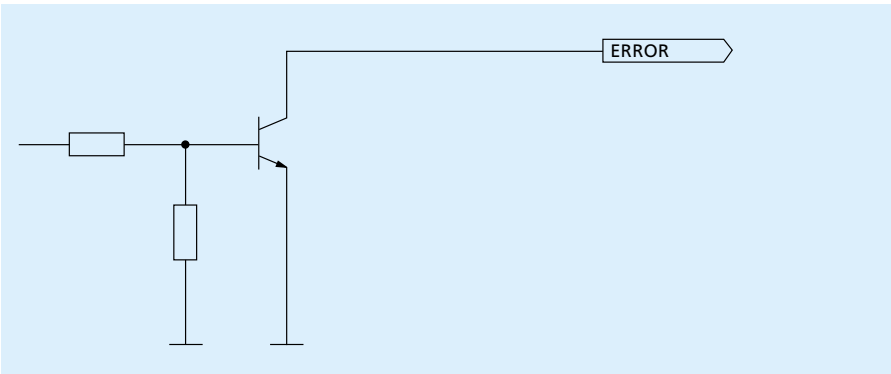

8.2.4. Motor C (3)

8.2.5. Motor B (2)

8.2.6. Motor A (1)

motor connection.

8.2.7. + 5 V, 100 mA (6)

auxiliary voltage source for power supply of hallsensors and/or incremental encoder

8.2.8. + 15 V 20 mA (14)

8.2.9. - 15 V 20 mA (16)

auxiliary voltage source for use as reference voltages by setting the set value by the means of an external potentiometer

Troubleshooting

9. Troubleshooting

Symptom	Operating mode	Causes	Repair
motor does not turn	all	■ power supply voltage < 11 V	check power supply
		■ enable not active	check level at pin 14
		■ set value = 0V	check set value
		■ current limitation adjusted too low	check potentiometer adjustment I_{max} .
		■ speed range too low	check potentiometer adjustment n_{max} .
		■ wrong operation mode	check jumper setting
		■ bad connections	check connectors
		■ wrong wiring	check wiring
no speed control	speed control encoder feedback	■ encoder signals	check signals and sequence
	speed control hall feedback	■ gain adjusted too low	check potentiometer adjustment, gain coarse and gain fine



FAULHABER

The FAULHABER Group:

**DR. FRITZ FAULHABER
GMBH & CO. KG**

Daimlerstraße 23
71101 Schönaich · Germany
Tel.: +49 (0)7031/638-0
Fax: +49 (0)7031/638-100
Email: info@faulhaber.de
www.faulhaber.de

MINIMOTOR SA

6980 Croglio · Switzerland
Tel.: +41 (0)91 611 31 00
Fax: +41 (0)91 611 31 10
Email: info@minimotor.ch
www.minimotor.ch

MicroMo Electronics, Inc.

14881 Evergreen Avenue
Clearwater · FL 33762-3008 · USA
Phone: +1 (727) 572-0131
Fax: +1 (727) 573-5918
Toll-Free: (800) 807-9166
Email: info@micromo.com
www.micromo.com