

Release tracking

File	Description	Date
V4900UM240904_CD	first tracked version	24.09.2004
V4900UM240205_DC	Release with new product	24.02.2005
V4900UM051005_CD	Updated PIN-out info and safety notice	05.10.2005
V4900UM241105_CD-R1	Correction of optional cable part number	24.11.2005
V4900UM161205_CD-R2	Correction of suitable motors	16.12.2005
V4900UM210706_CD-R3	Protection rating added, M2.5 screw correction	21.07.2006
V4900UM080408_CD-R4	Name Update Precistep	08.04.2008
V4900UM280611_CD-R5	Update of complete user manual	28.06.2011
V4900UM300611_CD-R6	Correction of the MOTOR connection pins	30.06.2011

Product denomination key

Typical Product type **AD CM M1S**

- AD** Driver product category
- C** Constant Current driver
- M** Mode
- M1** Function Mode
 - M1** = Pulse + direction drive, external control
 - M2** = Speed control drive w/o speed ramp (non-standard)
 - M3** = Speed control drive with speed ramp
- S** External connection type
 - S** = Screw type for all connectors

Support

You may inquire with your questions about the software or the driver by e-mail or directly with your sales office. It is in any case helpful to include the files you try to work with as well.

The e-mail contact address is:

info@precistep.com

Contents

1.	GENERAL INFORMATION	4
1.1	PRODUCT DESCRIPTION	4
1.1.1	<i>Available versions</i>	5
1.2	TECHNICAL SPECIFICATIONS	5
1.3	PROTECTION OF INPUTS AND OUTPUTS	6
1.4	SUITABLE PRECISTEP MOTORS	7
1.5	DIMENSIONS AND MOUNTING	8
2	SET-UP AND INSTALLATION OF AD CM M1S	9
2.1	BLOCK DIAGRAM	9
2.2	LOCATION OF COMPONENTS	9
2.3	CONNECTION OF THE DRIVES	9
2.3.1	<i>COMMAND connector</i>	10
2.3.2	<i>Switch for operation mode</i>	12
2.3.3	<i>LED busy (near COMMAND connector)</i>	13
2.3.4	<i>Motor A/Power Supply + Motor</i>	13
2.3.5	<i>Current setting, rotary switch (potentiometer)</i>	13
3	SET-UP OF THE AD CM M2S	14
3.1	BLOCK DIAGRAM	14
3.2	LOCATION OF COMPONENTS	14
3.3	ADJUSTMENT OF THE SPEED, FMIN POTENTIOMETER	15
3.4	OPERATION OF THE AD CM M2S	15
3.4.1	<i>Jumper ADJ = Adjust</i>	15
3.4.2	<i>Jumper VCO = Voltage Controlled Oscillator</i>	15
3.4.4	<i>Jumper CK = Clock</i>	15
4	SET-UP OF THE AD CM M3S	16
4.1	BLOCK DIAGRAM	16
4.2	LOCATION OF COMPONENTS	16
4.3	ADJUSTMENT OF THE SPEED PROFILE	16
4.3.1	<i>FMIN potentiometer</i>	17
4.3.2	<i>FMAX potentiometer</i>	17
4.3.3	<i>ACC and DEC Adjustment</i>	17
4.4	OPERATION OF THE AD CM M3S	18
4.4.1	<i>Switches/buttons RUN and STOP</i>	18
4.4.2	<i>Jumper ADJ = Adjust</i>	18
4.4.3	<i>Jumper VCO = Voltage Controlled Oscillator</i>	19
4.4.4	<i>Jumper CK = Clock</i>	19
5	SPECIAL NOTES	20
5.1	PULL-UP RESISTOR	20

1. General Information

1.1 Product Description

The main interest of the use of a current mode driver such as the AD CM models is the current control independent from the supply voltage (chopper). This allows to apply a much higher voltage than needed to drive the current without risk of overheat.

It leads to a more constant torque output of the motor and increases the maximal speed plus gives the possibility to boost the current if necessary.

The drivers AD CM M_S are specifically designed to control the phase current in current mode operation of PRECstep two phases stepper motors.

They offer:

- Full- and half-step operation
- Current control (preset currents – 16 levels of 50mA each)
- BOOST – current increase to 135% of set current level
- One-phase ON, two-phase ON operation (switch selection)
- STANDBY – activate or deactivate phase current to save energy
- INHIBIT – activate or deactivate phase current to save energy
- DISABLE- current is set to zero (windings open/shorted)
- STANDBY – current decay to 37% of set current level

Safety Note

DO NOT

**Connect motor phase outputs A+, A-, B+, B- to positive supply voltage input V+.
This will cause fatal damage to the driver.**

AVOID

Connecting and disconnecting the motor from the driver while it is powered on.

1.1.1 Available versions

The AD CM M_S is available in three different versions

- 1) **AD CM M1S** (Standard stock item)
Basic driver, requiring only clock and direction signals, it is destined to be controlled by a PC or any other host. A switch on the board enable the user to choose manually between one phase-on or two phase-on mode, clockwise or counter clockwise rotation and full or half step operation.
It is able to control the position of the rotor shaft. Note that any speed profile can be obtained depending on the host used for controlling the driver.

Please refer also to the "Product Block Diagram" in chapter 2.1.

- 2) **AD CM M2S** (Non-Standard – available on request only)
Basic drive AD CM M1S including a plug-in board with a pulse generator to run a stepper motor at a fixed speed. The speed is set manually with a potentiometer. This version is good for speed control in start-stop mode (pull-in) operation. Unplugging the blue jumpers will transform the unit into the AD CM M1S.
Typical speed profile possible with this driver:

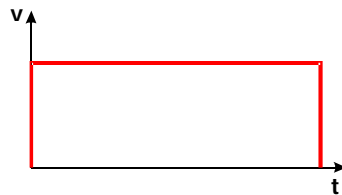

Please refer also to the "Product Block Diagram" in chapter 3.1.

- 3) **AD CM M3S** (Standard stock item)
Basic drive AD CM M1S including a plug-in board with a pulse generator to run a stepper motor with a trapezoidal speed profile starting/stopping at a given frequency. The start/stop frequency, maximum frequency, acceleration/deceleration time can be set manually with potentiometers. This is a standalone stepper motor controller mainly used for bench tests or demonstrators. Unplugging the blue jumpers will transform the unit into the AD CM M1S.
Typical speed profile possible with this driver:

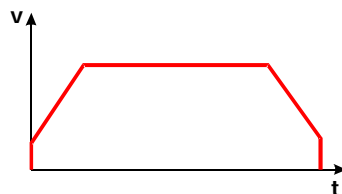

Please refer also to the "Product Block Diagram" in chapter 4.1.

1.2 Technical Specifications

As the AD CM M_S is a Current Mode Driver, the current level is preset by on-board switches with steps of 50mA.

It is designed to drive the small stepper motors in full step or half step, one phase-on or two phase-on, clockwise or counter clockwise.

			AD CM M1S	AD CM M2	AD CM M3S
Power supply voltage	Min Max	V	10 28		
Power supply current		mA	13		
Motor Output current	max.	mA	750		
Output current setting	0..15	mA	Can be set in 16 steps of 50mA from 0 to 750mA		
Logic input level	low high	V	0 to 0.6 (+10% max) 1.6 to 24		
Direction of rotation			cw/ccw		
Step mode			full step (one phase ON or two phase ON) half step (one phase ON)		
Step frequency (speed)	Min max.	full step/s	0 ---	10* 6000	10* 6000
Dimensions		mm	83.2x53.5x12	83.2x53.5x21	83.2x53.5x21

* If using the internal clock generator

1.3 Protection of Inputs and Outputs

The AD CM M_S versions are offering increased protection levels for the inputs and outputs as presented in the list below.

Driver output short-circuit			AD CM M_S
Driver OUT	versus	GND	😊 protected
Driver OUT	versus	V+	😞 not protected
Driver OUT	versus	Pin 1-2	😊 protected
Driver OUT	versus	Pin 1-3	😊 protected
Driver OUT	versus	Pin 1-4	😊 protected
Driver OUT	versus	Pin 2-3	😊 protected
Driver OUT	versus	Pin 2-4	😊 protected
Driver OUT	versus	Pin 3-4	😊 protected

Protection on COMMAND			AD CM M_S
Inputs	versus	V+	😊 protected
Inputs	versus	GND	😊 protected
Outputs	versus	V+	😞 not protected
Outputs	versus	GND	😊 protected
Pin +5V	versus	GND	😞 not protected

Note

If one of the non protected events occurs, the driver will be damaged.

1.4 Suitable PRECISTEP Motors

The driver of the series AD CM M_S is specifically suitable for motors with windings designed for constant current control.

Motor Type	Winding	Current setting (switch position)	Voltage setting (recommended)
AM0820	V-3-18	3	16 V
AM1020	A-0,25-8	5	12 V
ADM1220(S)	V2	6	10 V
ADM1220(S)	V3	4	15.5 V
AM1524	A-0,25-12,5	5	18.5 V
AM1524	A-0,45-3,6	9	10 V
AM1524	V-6-35	3	27 V
AM2224(-R3)	AV-4,8	10	14.5 V
AM2224(-R3)	AV-18	5	27 V

For other stepper motors, the current control mode is possible but not optimal.

Motor Type	Winding	Current setting (switch position)	Voltage setting (recommended)	Notes
ADM0620	V3	1	10 V	33% torque reduction
ADM0620	V6	-	-	Definitely not recommended for current mode
AM0820	V-5-56	1	17 V	38% torque reduction
AM0820	A-0,225-7	4	10 V	12% torque reduction
AM1020	V-3-16	3	14.5 V	17% torque reduction
AM1020	V-6-65	1	19.5 V	45% torque reduction
AM1020	V-12-250	-	-	Definitely not recommended for current mode
ADM1220(S)	V6	1	14.5 V	45% torque reduction
ADM1220(S)	V12	-	-	Definitely not recommended for current mode
AM1524	V-12-150	-	-	Definitely not recommended for current mode
AM2224(-R3)	AV-0,9	15 (max)	10 V	35% torque reduction
AM2224(-R3)	AV-12-75	-	-	Definitely not recommended for current mode

Notes

- The settings of the second table use a lower current than the nominal current recommended in the datasheet (that is why torque is reduced in most cases). It is possible to set a higher current but the temperature may rise very quickly causing irreversible damages to the motor.
- It is often possible to set the current to a close matching value by using the boost function. The idea is then to set the current to a lower value and increase it up to 135% by using the PIN7 of the COMMAND connector (see section 2.3.1 for more information). However, this solution is not direct and requires controlling externally the boost function.
- Also, when the current setting is not appropriated to the winding, please note that some motors may offer a reduced operational speed because of their high back-EMF.
- Generally speaking, the higher the voltage of the supply is, the more torque the motor will develop at high speed.

1.5 Dimensions and mounting

The drivers can be mounted by using the four holes on the board. However, the M2 and M3 consist of two boards assembled through these holes, which means that you have to fix the driver by using 4 screws M2.5.

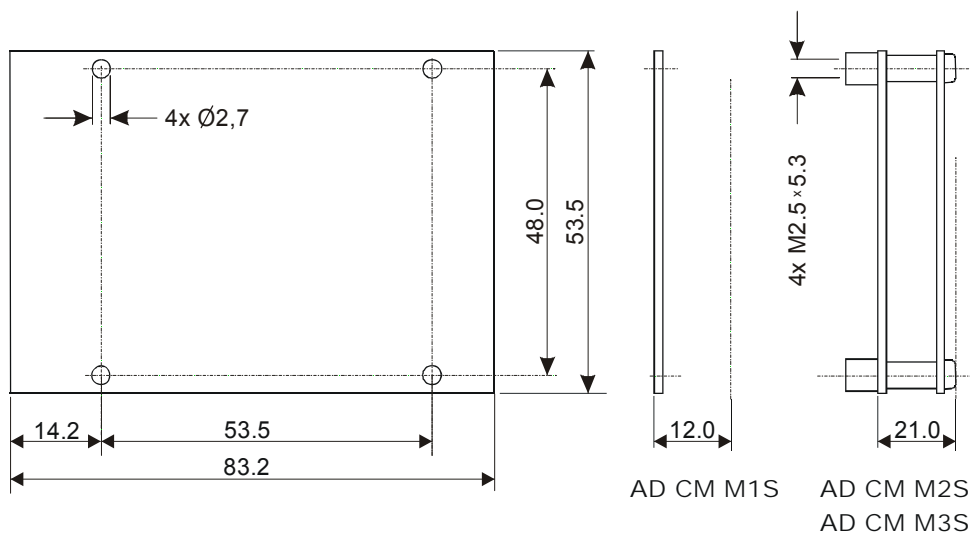

2 Set-up and installation of AD CM M1S

This section refers to all functions offered by the stepper motor driver type AD CM M1S. The set-up of the M2S and M3S version is the same, relatively to the functions of the M1S, but offers some additional functionalities.

2.1 Block Diagram

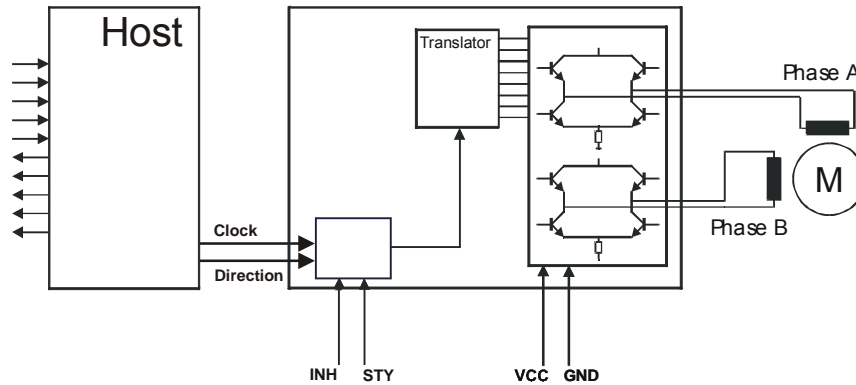

2.2 Location of Components

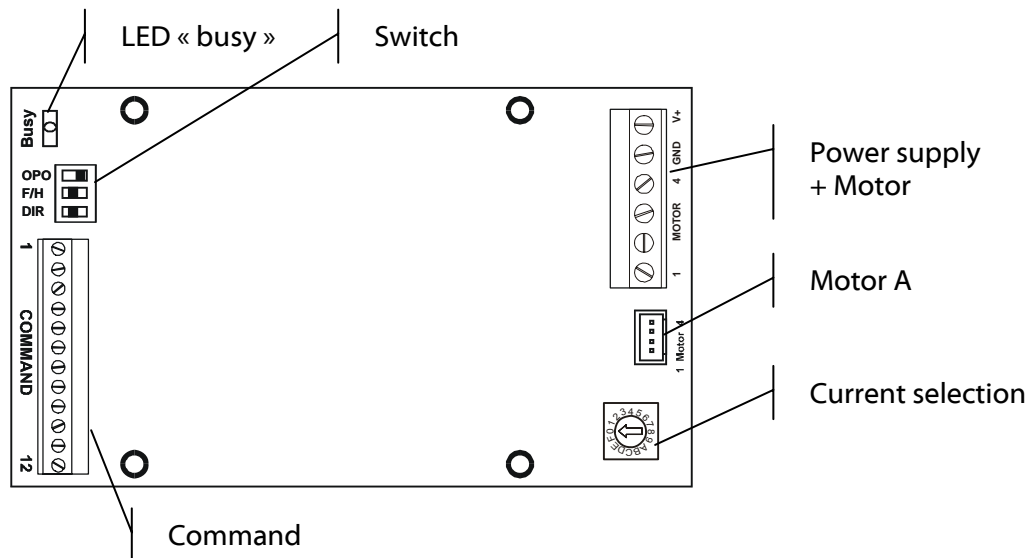

- COMMAND, screw-type terminal, 12-positions
- MOTOR A, locking connector, Molex 4-pins miniature
- POWER SUPPLY + MOTOR, screw type terminal, 6-positions
- Switch, manual switch, 3-pins
- Current selection, screw type potentiometer, 16-positions
- Status LED "busy" indicator

For Pin-out and functional explanations, please see the respective section.

2.3 Connection of the drives

This section will introduce the functions of the Version AD CM M1S, which are identical for all versions of the AD CM M_S.

Please refer to sections 3 and 4 for the installation and set-up of the additional functions offered by the versions AD CM M2S and AD CM M3S.

Note

Both M2S and M3S versions can be used as M1S version if the jumpers ADJ, VCO and CK on the mezzanine board are removed (see section 3 and 4 for more information about the jumpers).

2.3.1 COMMAND connector

Input voltage for all inputs varies from 5 to 24VDC

This 12-pins connector is available on all driver versions, it provides access to all functionality.

#	I/O Type	Designation	Explanation	M1	M2	M3
1	I	1-PH ON	Full-step; 1-phase ON (wave)	X	X	X
2	I	FS/HS	Full Step/Half Step mode switch	X	X	X
3	I	CCW/CW	Sense of rotation switch, default = CW	X	X	X
4	I	CLK ¹	External clock input	X	X	X
5	I	RUN	Starts the clock generator		X	X
6	I	STOP	Stops the clock generator		X	X
7	I	BOOST	Current boost	X	X	X
8	O	BUSY	Output = Low when clock is active		X	X
9	I	STB	Current Standby	X	X	X
10	O ²	VCC	+5V power supply (max 200mA)	X	X	X
11	O	GND	Ground potential ≥ 0 Volt	X	X	X
12	I	VCO	External control voltage for the oscillator (VCO)		X	X
12 ³	O	HOME	Active when Phase A is commutated with positive current	X		

¹ CLK input is active on positive trigger signal

² Output, sink and source pins, to connect directly

³ PIN12 can be set as input or output. Please refer to PIN12 description below.

Functional description of the Inputs/Outputs on COMMAND connector:

PIN1, Operation mode Selection
Selection can be one phase-ON (LH*) or twp phase-ON (LL) commutation
Input is not active if not connected
With one phase-ON, the motor provides the same torque than with two phase-ON mode, but with a lower current consumption. In phase-ON, the AD CM M1S automatically increases the current in the motor phase by a factor of 1.4, meaning that the current consumption is 1.4 x I_{nominal} instead of 2 x I_{nominal} in two phase-ON.

PIN2 Step resolution selection
Input is not active if not connected.
Selected can be Full-step (LL*) or Half-step (LH)
If PIN1 is active, only full-step operation is possible

PIN 1+2 Truth table

PIN 1	PIN 2	Function mode
LL*	LL	Full-step, two phase-ON
LH	LL	Full-step, one phase-ON
LL	LH	Half-step (two phase-ON)
LH	LH	Full-step, one phase-ON

*LL for Logic Low and LH for Logic High (see table of section 1.2 for values). LL can also mean that the PIN is not connected.

PIN3 Direction of rotation (high active)
The signal can be changed at any time but it takes effect after the next following clock pulse. If the clock and direction signals are triggered at the same time, the step execution will change immediately.

Warning:
As PIN1 to 3 are high-active inputs, the switches for operation mode (see section 2.3.2) must all be in the OFF position so that they can be activated.

If this warning condition is respected, then the high logic level applied on the pin will set the direction to counterclockwise for the AM1524 stepper motor and clockwise for all others (see also the truth tables in section 2.3.2 for more information about the sense of rotation).

PIN4 External clock signal.
This input enables the host to set the position of the rotor to an exact number of steps and control the speed of rotation. Each positive trigger pulse moves the motor by one step (full-step or half-step dependent on setting of PIN1 or 2).
It is independent from START and STOP signals and is active as long as a signal is provided in PIN4.

Warning:
If PIN4 is activated, do not enable the START or STOP signals. This may superpose the external and internal clock generator resulting in an uncontrolled motion of the motor.

PIN5 RUN Command - only available on M2 and M3 version,
Activated by a positive edge of the signal
It starts the motion of the rotor by loading and enabling the internal clock signal only (no effect on external clock generator)

PIN6 STOP Command - only available on M2 and M3 version,
Activated by a positive edge of the signal
It stops the motion of the rotor by loading and enabling the internal clock signal only (no effect on external clock generator)

PIN 7 Current boost operation
The current increases by a factor of 1.35 as long as this input is active
For more information see PIN7+9 truth table below (under Pin 7+9).

PIN8 BUSY output
Active on M2 and M3 when internal clock of these drivers are operating.
On the M1 version the LED is switched on for 10ms per clock signal when $f < 100\text{Hz}$, and switched on continuously, as a return signal for the host that the clock has been taken, when $f > 100\text{Hz}$.
Open collector output, not short circuit protected.

PIN9 Standby signal
Current to the motor phases is reduced to 37% of the operation current level as long as this input is active
For more information see PIN7+9 truth table below (under Pin 7+9).

PIN7+9 Truth table

Pin 7 Boost	Pin 9 Standby	Function
LL*	LL	Enable
LL	LH	Standby
LH	LL	Boost
LH	LH	Disable

*LL for Logic Low and LH for Logic High (see table of section 1.2 for values).

PIN10 +5V power supply **output**
Maximum current 200mA, source output

- PIN11 GND output (for the VCO voltage source - only available on M2 and M3 version)
- PIN12 Input VCO or Output HOME
the selection is done by a solder bridge behind the command header
- HOME is a function needed to know the commutation position of the driver.
It is activated every time Phase A of the motor is energized with positive current.
This helps to home the clock of the host to the driver commutation, a function helpful to avoid step losses when power to the driver is lost.
Note that with a stepper motor, it is important to start from where you stopped. For instance, if the motor stopped on step 3 out of 20 per revolution, the next motion must start again from step 3. This means that the windings have to be energized as they used to be before the motor stops or it will lose steps. The HOME output is actually memorizing those information.

VCO input - only available on M2 and M3 version
Range = 0 to 5V corresponding to zero up to 6000Hz max.
Switching from full to half step operation or vice versa will not change the motor shaft speed.

Warning:
In case that the described input signals to the driver are generated by an open collector output PLC, it will be necessary to add, depending on the type of output of the PLC, a pull-up or pull down transistor.

2.3.2 Switch for operation mode

To operate the driver, it is also possible to work without using the COMMAND connector. In this case the selection of the drive mode is done manually and directly on the board thanks to a 3-position switch.

Their operation is as follows:

Switch	Switch Function
OPO	1-PH ON selector
F/H	Full-step, Half-step selector
DIR	Sense of rotation

Truth table for the 1-PH ON and F/H Switches

Status OPO	Status F/H	Function mode
OFF*	OFF	Full-step, two-phase ON
ON	OFF	Full-step, one-phase ON**
OFF/ON	ON	Half-step (two-phase ON**)

Truth table for the DIR Switch

Status DIR	Function mode
OFF*	Clockwise for the AM1524 motor Counterclockwise for all others
ON	Counterclockwise for the AM1524 motor Clockwise for all others

* The OFF position is at the edge of the driver.

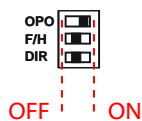

** Current correction is automatically activated, torque remains the same in all rotor positions.

2.3.3 LED busy (near COMMAND connector)

On the M2S and M3S versions the LED will be active when motor is moving or internal clock is active.
On the M1S version it will be triggered by the external clock for 10ms when $f < 100\text{Hz}$ and be continuously ON when $f > 100\text{Hz}$.

2.3.4 Motor A/Power Supply + Motor

The driver comes with a screw type terminal for the connection of the power supply and the motor.

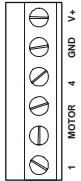
	Pin #	Function	Motor PIN
	1	V+	-
	2	GND	-
	3	Phase A +	4
	4	Phase A -	3
	5	Phase B +	2
	6	Phase B -	1

It is also possible to directly connect the motor by using a Molex connector.

	Pin #	Motor Phase	Motor PIN
	1	Phase B -	4
	2	Phase B +	3
	3	Phase A -	2
	4	Phase A +	1

Connector Type: Molex 4 poles Nr 53047-0410
Mating Connector: Molex 4 poles Nr 51021-0400 with pins Molex 50058-8000

A cable with this mating connector is not supplied with the driver or the motor.
Please refer to the cable list of PRECIstep to find a suitable cable.

2.3.5 Current setting, rotary switch (potentiometer)

	Rotary Position	Current level [mA]
	0	0
	1	50
	2	100
	3	150
	4	200
	5	250
	6	300
	7	350
	8	400
	9	450
	A	500
	B	550
	C	600
	D	650
	E	700
	F	750

3 Set-up of the AD CM M2S

This driver version includes the function of the AD CM M1S and additionally offers a mezzanine (plug-in) board with the following characteristics:

- On-board clock generator
- Speed setting through a potentiometer

The functions are partially shared with the M1 board and to determine the function of the plug-in board with the M1 base board, a series of jumpers is available.

Note

The driver AD CM M2S do not offer a speed ramp, they are able to operate the motor only at a single speed which has to be reached during the first step, generally at less than 200-600 Hz (depending on load)

3.1 Block Diagram

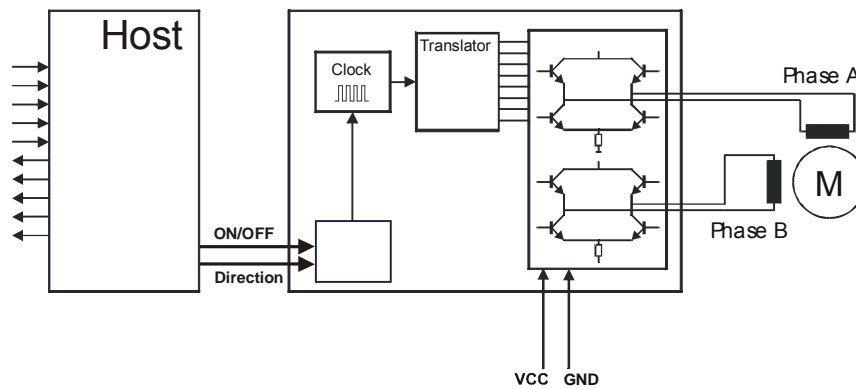

3.2 Location of Components

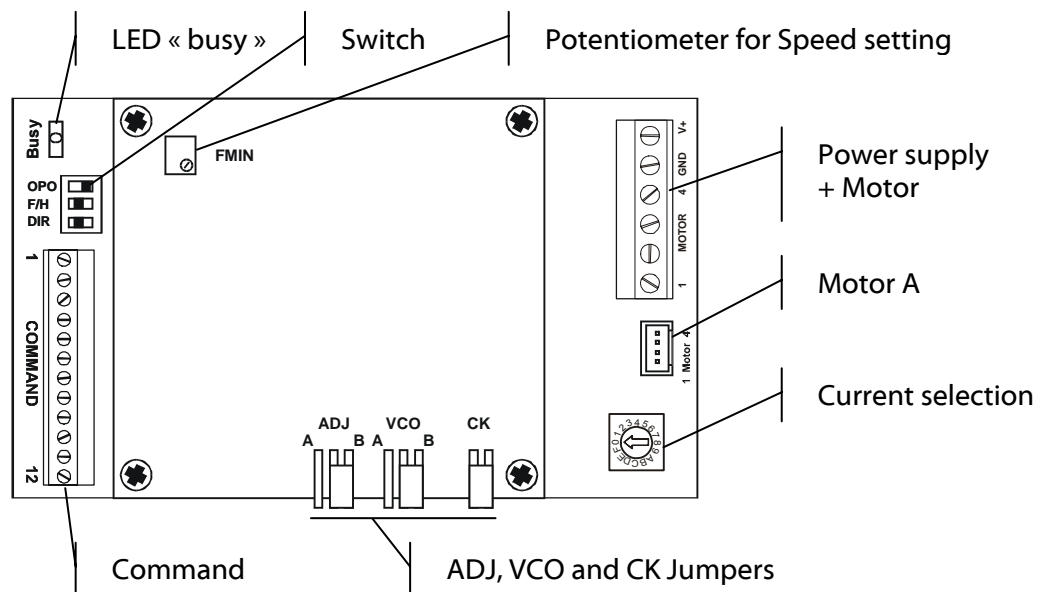

3.3 Adjustment of the speed, FMIN potentiometer

To set-up the motor speed

- Turn FMIN potentiometer CCW to zero
- Set Jumper ADJ to position A
- Set Jumper VCO to position A
- See whether the motor starts and adjust FMIN potentiometer until the motor starts with the application load. This determines the maximally possible pull-in frequency. It is however possible to set the speed to any lower value.

Note

- The motor will reach the FMIN speed within the first step (pull-in speed range), no ramp is used. If the motor is unable to rotate due to an excessive speed, please consider the use of an AD CM M3S.
- The FMIN speed ranges from 10 to 6000 steps/s

3.4 Operation of the AD CM M2S

- Jumpers VCO and ADJ in Position A involve that the motor starts upon power up and the inputs RUN, STOP have no function
- Jumper VCO in Position A, Jumper ADJ in Position B involve that the motor will react on the inputs RUN, STOP
- Jumper CK will set either internal or external clock generator

3.4.1 Jumper ADJ = Adjust

Position A

The motor rotates at the set FMIN operation speed settings upon power up.

Position B

The motor rotates at the set FMIN operation speed settings according to the RUN and STOP inputs signals.

Input RUN active (PIN5):	motor will operate at FMIN speed
Input STOP active (PIN6):	motor will stop

3.4.2 Jumper VCO = Voltage Controlled Oscillator

Position A

The on-board frequency generator is activated, motor speed is set by the on-board FMIN potentiometer.

Position B

The external Analogue Speed Reference input is used (PIN 12 on COMMAND connector).

3.4.4 Jumper CK = Clock

Jumper SET:	the internal clock generator is active but PIN 4 on COMMAND connector is still active too.
-------------	---

Jumper NOT SET:	only the external clock signal will be taken into account (clock signal must be provided on PIN 4 on COMMAND connector).
-----------------	--

4 Set-up of the AD CM M3S

This driver version includes the function of the AD CM M1S and additionally offers a mezzanine (plug-in) board with the following characteristics:

- On-board clock generator
- Speed setting through potentiometers (max/min speed, acceleration/deceleration ramp)
- RUN and STOP button

The functions are partially shared with the M1 board, to determine the function of the plug-in board with the M1 base board, a series of jumpers is available.

4.1 Block Diagram

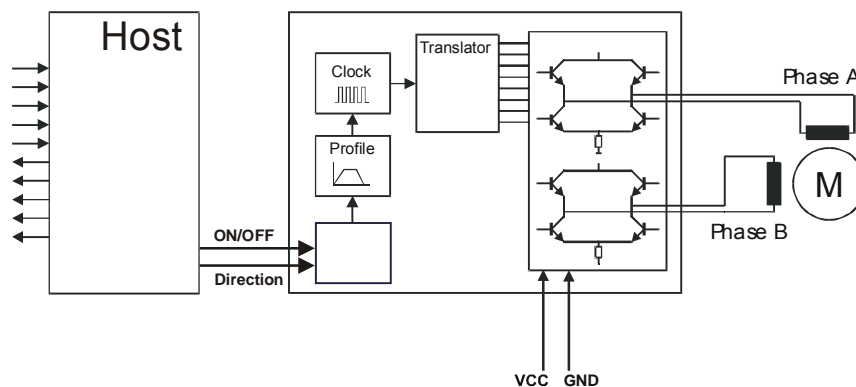

4.2 Location of Components

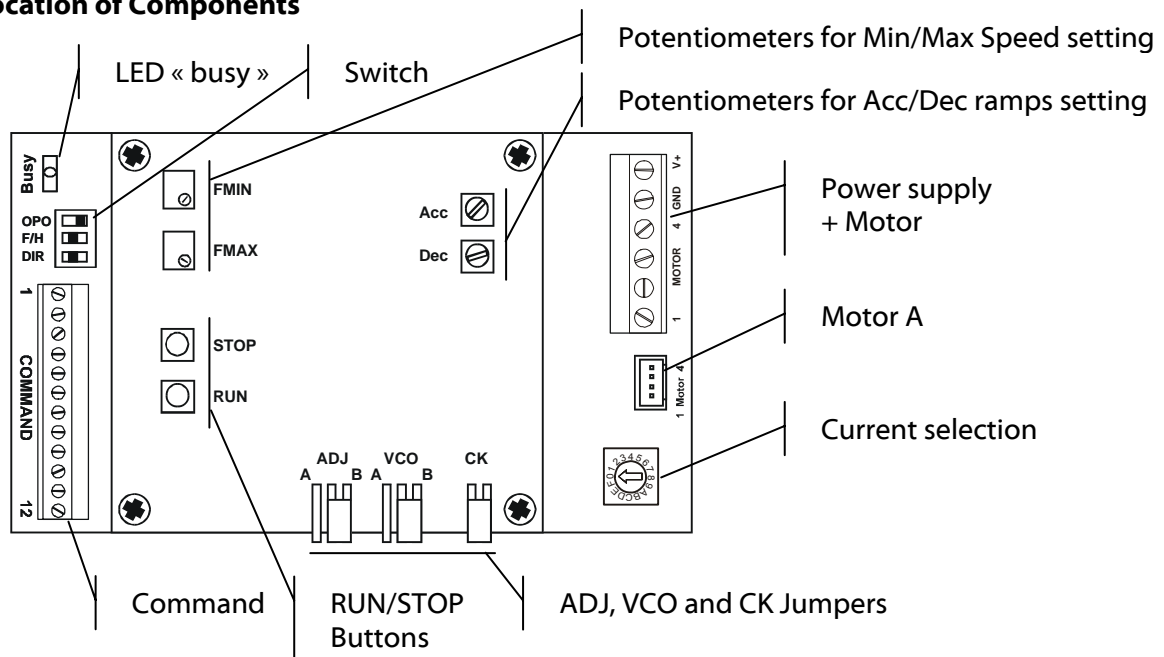

4.3 Adjustment of the Speed Profile

The Potentiometers FMIN, FMAX, ACC and DEC located on the plug-in board are used to set the parameters of the speed profile selected to move the motor. The function and adjustment methods are explained below.

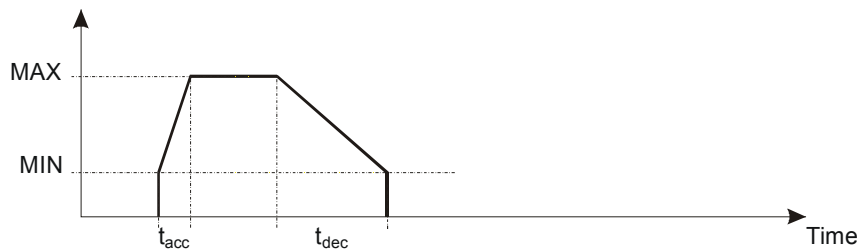

4.3.1 FMIN potentiometer

Function:

The potentiometer serves to set the minimum speed of the motor (pull-in).

To set-up the minimum speed

- Turn FMIN potentiometer CCW to zero (CCW = min speed ↺, CW = min speed ↻)
- Set Jumper ADJ to position B
- Press RUN to see whether the motor starts and adjust FMIN potentiometer until the motor starts with the application load.

Note

- The motor will reach the MIN speed within the first step (pull-in speed range) if no ramp is set with ACC and DEC potentiometers.
- The FMIN speed ranges from 10 to 6000 steps/s

4.3.2 FMAX potentiometer

Function:

The potentiometer is used to determine the maximum speed the motor will reach. To reach this speed the motor may require an acceleration and deceleration ramp.

The set-up is done as follows:

- Set the min speed to its lowest value if necessary (turn FMIN CCW to zero)
- Set the ACC and DEC ramp by adjusting the corresponding potentiometers on the board (see ACC and DEC Adjustment)
- Set the max speed by adjusting the FMAX potentiometer (CCW = max speed ↺, CW = max speed ↻)
- Set Jumper ADJ to position B
- Press RUN to see whether the motor starts. If the motor does not accelerate to the speed (stalling of motor shaft), press STOP and increase the ACC time (acceleration time given to the motor to reach the FMAX speed) by turning the ACC potentiometer CCW. It may also happen that you have to decrease the max speed.

Note

Maximum speed changes if FMIN setting is changed, the difference is kept constant.

4.3.3 ACC and DEC Adjustment

Function:

The potentiometers adjust the time during which the motor will accelerate from FMIN to FMAX speed or decelerate from FMAX to FMIN speed.

- Turning the potentiometers CW will decrease the acceleration time and increase the acceleration rate (t_{acc} and t_{dec} ↻), the motor speed increases/decreases faster

- Turning the potentiometer CCW will increase the acceleration time and decrease the acceleration rate (t_{acc} and t_{dec} ↗), the motor speed increases/decreases slower

4.4 Operation of the AD CM M3S

- The Buttons RUN/STOP allow to operate the motors manually.
See details below.
The functions RUN/STOP are also available on the COMMAND connector and are operating in parallel to the switches.
- Jumpers VCO and ADJ in Position A involve that the motor starts upon power up and the inputs RUN, STOP have no function
- Jumper VCO in Position A, Jumper ADJ in Position B involve that the motor will react on the inputs RUN, STOP
- Jumper CK will set either internal or external clock generator

4.4.1 Switches/buttons RUN and STOP

RUN Function:

The motor starts to accelerate when RUN is activated or pressed.

Note

the PIN 5 on the COMMAND connector has the same function, in case that the PIN 5 is activated (5 to 24VDC applied), the RUN button has no function.

STOP Function:

The motor starts to decelerate when STOP is activated or pressed.

Note

the PIN 6 on the COMMAND connector has the same identical function, in case that the PIN 6 is activated (5 to 24VDC applied), the STOP button has no function

4.4.2 Jumper ADJ = Adjust

Position A

The motor rotates on the set FMIN and FMAX operation speed settings.

Button RUN pressed:

Acceleration from FMIN speed to FMAX speed

Button STOP pressed:

Motor will decelerate but will continue to run at the speed setting of the FMIN.

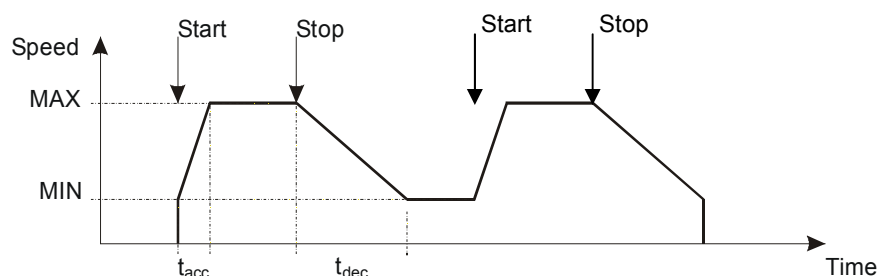

Position B

The motor rotates on the set FMIN and FMAX operation speed settings but will stop automatically after the deceleration (when the FMIN speed has been reached)

Button RUN pressed:

Acceleration from MIN speed to MAX speed

Button STOP pressed:

Motor will decelerate and stop rotating

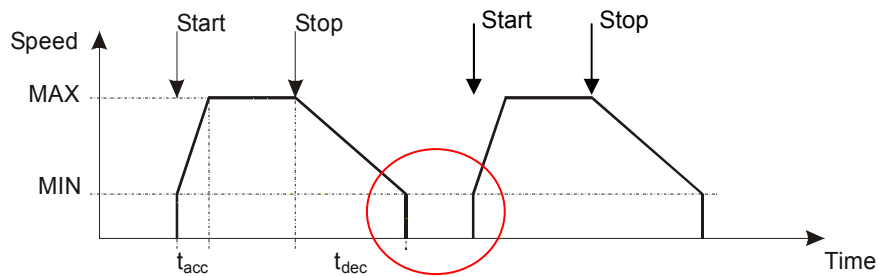

4.4.3 Jumper VCO = Voltage Controlled Oscillator

Position A

The on-board frequency generator is activated, motor speed is set by the on-board FMIN potentiometer.

Position B

The external Analogue Speed Reference input is used (PIN 12 on COMMAND connector).

4.4.4 Jumper CK = Clock

- | | |
|-----------------|--|
| Jumper SET: | the internal clock generator is active but PIN 4 on COMMAND connector is still active too. |
| Jumper NOT SET: | Only the external clock signal will be taken into account (clock signal must be provided on PIN 4 on COMMAND connector). |

5 Special NOTES

5.1 Pull-up resistor

Pull-Up

The inputs of the drivers namely clock, direction, START/ STOP are open collector inputs.

Open Collector (or Open Drain) output is frequently offered by programmable logics because of their higher safety. They require an adaptation to the AD driver series with a PULL-UP resistor.

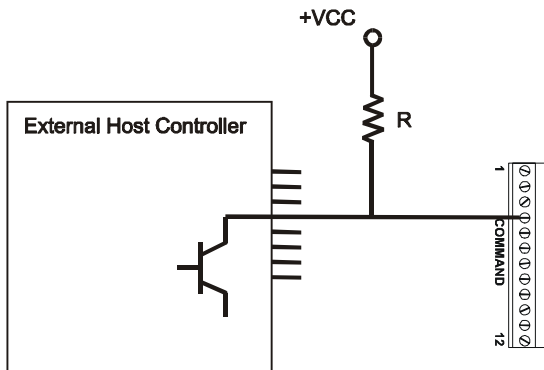

This configuration is necessary for the inputs/outputs 1-7 of all PRECistep drivers.

The value of resistor used to pull up an open-collector is not critical. Smaller values offer faster switching times at the price of higher current consumption.

Typical values range from a few thousand to a few hundred thousand Ohms.

Please note that the signal is inverted this way.